

GUIDE FOR THE FITTING OF BODYWORK FOR THE RENAULT MAGNUM

50 21 008 252 - 06/02
édition anglaise

IMPORTANT

Reading the "Guide for the Fitting of Bodywork for the RENAULT MAGNUM E-TECH "

The "Guide for the Fitting of Bodywork for the RENAULT MAGNUM E-TECH" ushers in a new type of presentation for bodywork fitting guides.

This new presentation sets out in one single document all those details that are necessary for the bodybuilder and equipment manufacturer to have available.

The present document consists of three sections:

- A - "General features": This describes the relevant general principles and basic rules applicable for the conversion and fitting of equipment to vehicles in most cases for the majority of applications.
- B - "RENAULT MAGNUM E-TECH special bodybuilding features": This deals in greater detail with presentation of the vehicle, attachment of the body, electrical pre-arrangements, trade vehicles and trade packs.
- C - "Supplementary information on the RENAULT MAGNUM E-TECH vehicle": This deals in greater detail with power take-offs, air-operated and specific equipment, assembly of equipment to chassis and cab.

If a topic is dealt with in the three sections, the relative information may be:

- **complementary**: in this case the "Special bodybuilding features" section provides details or values relating to the topic dealt with in "General features".
- **partially or fully contradictory**: when the RENAULT MAGNUM E-TECH vehicle is endowed with a special feature whose characteristics go against general principles. In such case, the elements regarding this specificity in the "Special bodybuilding features" section supersede those dealing with the same topic in the "General features" section.

You may need, when looking for information on a specific point, to consult the three "General features", "Special bodybuilding features" and "Supplementary information on the RENAULT MAGNUM E-TECH vehicle" sections, so as to ensure that you have obtained all the relevant details.

The information given by the Manufacturer in this document is compiled in relation to the technical specifications in force on the date of drafting of the document.

It is subject to modification in the event of changes made by the OEM during the manufacture of the different units and accessories for vehicles of its make.

Carrossiers & Equipementiers
ATTENTION
véhicule électronique EURO3
Respecter IMPERATIVEMENT
les consignes de carrossage
ou
Contacter le constructeur

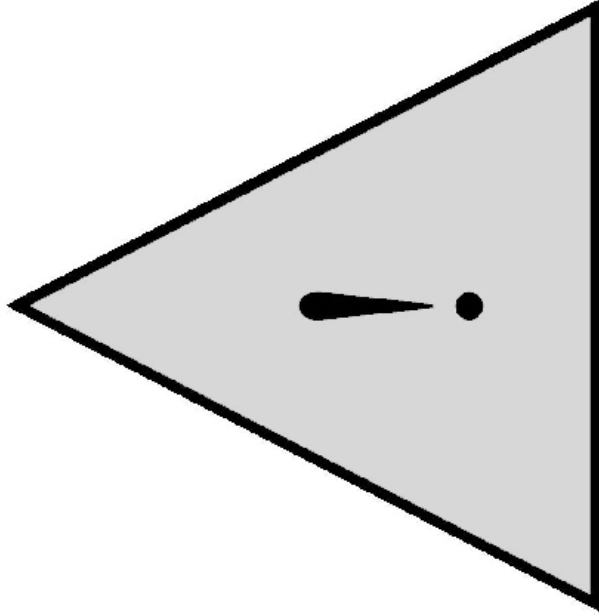

Karosseriebauer & Ausstatter
ACHTUNG
Fahrzeug mit Elektronik EURO 3
UNBEDINGT die Hinweise
für die Aufbauten beachten oder
sich an den Hersteller wenden.

Bodybuilders & Equipment Manufacturers
WARNING

EURO 3 electronically managed vehicle
It is **ESSENTIAL** to comply with
bodybuilding instructions

or
Contact the vehicle manufacturer

Carroceros y proveedores de equipos
ATENCION
Vehículo electrónico EURO 3
Respetar **OBLIGATORIAMENTE**
las instrucciones de carrozado
o
contactar con **RENAULT V.I**

Carrozzeri e Allestitori
ATTENZIONE

Veicolo con elettronica EURO 3
Rispettare **TASSATIVAMENTE**
le istruzioni per la carrozzatura

o
Contattare il costruttore

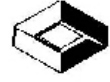

RENAULT

CONTACTS

Belgique België

RENAULT TRUCKS Belgique SA

Avenue du port 138,
1000 Bruxelles

Correspondant carrossier	Téléphone	fax
	02.421.76.31	02.425.56.06

Ceská Republika

RENAULT TRUCKS CR s.r.o.

Saldova 425/12,
18621 Praha 8,
Ceská Republika

Technicky inspektor	Téléphone	fax
	420/2/24 23 20 80	420/2/24 23 20 84

Deutschland

RENAULT LKW Deutschland GmbH

Renault StraBe 12,
50321 Brühl

Verkaufstechn. und Aufbauberatung	Téléphone	fax
	02232/7077142	02232/7077181

España

RENAULT TRUCKS España, s.a.

C/Eduardo Barreiros, 104
28080 Madrid

Tecnico comercial	Teléfono	fax
	91 347 11 91	91 347 11 68

France

RENAULT TRUCKS

99, route de lyon, BP310
69800 Saint-Priest

Technico comercial	Téléphone	fax
	04 72 96 96 70	04 72 96 81 93

Great-Britain

RENAULT TRUCKS UK Ltd,

Boscombe Road,
Dunstable,
Bedfordshire LU5 4LX

Applications Engineering Manager	Téléphone	fax
	01582 479150	01582 479328

Italia

RENAULT TRUCKS Italia S.P.A.

Via Castiglioni 20,
20010 Arluno (MI)

Marketing	Telefonico	fax
	02-902521	

Magyarország

RENAULT TRUCKS Hungária Kft.

2046 Törökbálint, Tó Park
Magyarország

Műszaki-kereskedelmi munkatárs	Telefon	fax
	00 36 23 513 583	00 36 23 513 514

Nederland

RENAULT TRUCKS Nederland B.V.

Edisonweg 8
4132 PC Vianen

Begeleiding carrosseriebow	Téléphone	fax
	+ 31 347 323 624	+ 31 347 323 650

Österreich

RENAULT LKW Österreich

Industriestrasse 5
A-2353 Guntramsdorf

Dispo	Téléphone	fax
	02236/41171 DW 25	02236/860166

Polska

RENAULT TRUCKS Polska Sp.Z.o.o.

ul. Polczynska 10
01-378 Warszawa

Dyrektor Techniczny	Telefon	fax
	+ 48 22 533 0200	+ 48 22 533 0333

Portugal

RENAULT TRUCKS Portugal Lda.

EN1-KM 29
2600/660 Castanheira do Ribatejo

Técnico-comercial	Teléfono	fax
	263 280864	263280850

Schweiz Suisse Svizzera

RENAULT NUTZFAHRZEUGE (Schweiz) AG

Rütiweg 5
4133 Pratteln

Responsabile tecnico	Téléphone	fax
	(061) 821.08.11	(061) 821.08.17

Slovenská Republika

RENAULT TRUCKS CR s.r.o.

organizacná zložka RENAULT TRUCKS SR

Teslova 30, P.O. BOX 168, 820 05
Bratislava 25,
Slovenská Republika

Obchodno-Technický inspektor	Téléphone	fax
	421/2/43 41 27 96-7	421/2/43 63 36 01

Türkiye

RENAULT TRUCK Ticaret A.

Hülagül Cad. Tepeüstü Sok. No: 30
81610 / Kavac k / Beykoz / Stanbul

Bayi Geli im Planlama Müdürü	Téléphone	fax
	+ 90 216 413 69 16	+ 90 216 331 21 98

CONTENTS

GENERAL RULES FOR CONVERSIONS

CHAPTER -A- GENERAL FEATURES

Page

1. GENERAL FEATURES	
1.1 Scope of liability	A2
1.2 Regulations	A2
1.3 Safety	A3
1.4 Quality assurance	A4
1.5 Documentation	A4
1.6 General instructions	A5
1.7 Safety on tilt cabs	A6
1.8 Chassis markings	A6
1.9 Adjustments to the vehicle settings	A7
1.10 Cleaning	A7
1.10.1 Bodywork	A7
1.10.2 Chassis/Underbodies	A7
1.10.3 Cleaning of the cab	A7
1.10.4 Cleaning of the instrument panel	A7
1.11 Safety and protection of components	A7
1.12 Summary of definitions	A8
1.13 Certificate of approval of the conversion of a vehicle	A9
1.13.1 Application for approval	A9
1.13.2 Body fitting certificate	A9
1.13.3 Responsibility for installation	A9
1.14 Painting	A10
1.14.1 Precautions	A10
1.14.2 Major units	A10
1.14.3 Chassis frame and accessories	A11
1.14.4 Recommended products	A12
1.14.5 Marking of polymer components (recycling of plastics)	A13
1.15 Electrical equipment	A15
1.15.1 General	A15
1.15.2 Wiring Harnesses	A15
1.15.3 Electrical connections	A16
1.15.4 Available power supplies	A16
1.15.5 Flasher units	A16
1.15.6 List of standard power sockets	A17
1.15.7 Additional direction indicator lamps	A17
1.16 Air-operated equipment	A20
1.16.1 Regulations	A20
1.16.2 Polyamide pipes	A20
- Identification marking	A20
- Coding used on polyamide pipes (RENAULT TRUCKS Standard)	A20
- Brakes code	A20
- Coding used on pneumatic appliances (DIN Standard)	A21
- Replacement of a brake line	A21
- Modification to the length of the chassis	A21
- Connections for firtree type pneumatic brake pipes type "RILAX 2000"	A21

2. GENERAL RULES TO BE OBSERVED WHEN FITTING BODYWORK

2.1 General welding principles	A22
2.1.1 Precautions	A22
- Protection of the batteries	A22
- Soundproofing screens	A22
- Protection of electrical and mechanical components	A22
2.1.2 Preparation of parts for welding	A22
- Preparation of specific edges on chassis frames	A23
- Method of welding to be specifically used on chassis frames	A23
- Slave butts	A23
2.1.3 Welding process	A24
- Static or rotary arc welding set	A24
- Relevant standards	A24
- MIG or MAG semi-automatic welding set	A24
2.1.4 Equivalent steel grades	A25
2.2 Reinforcement, extension, reduction of sidemembers	A26
2.2.1 Bans	A26
2.2.2 Reinforcement of sidemembers	A26
- Examples of reinforcements	A26
- Method of joining	A27
- Extension, shortening of sidemembers in the wheelbase	A28
2.2.3 Modification of the rear overhang	A29
- Attachment of cross-members	A29
- Drawbar cross-members	A29
- Intermediate cross-members	A29
2.3 Attachment of bodywork	A30
2.3.1. Bans	A30
2.3.2 Protection against exhaust heat radiation	A30
2.4 Sub-frames	A31
2.4.1 Finishing of sub-frames behind the cab	A31
2.5 Nuts and bolts, tightening torque for parts in steel and cast iron	A33
2.6 Addition of equipment to the bodywork	A34
2.7 Rear run-under guard	A35
3. SPECIFIC EQUIPMENT FEATURES	
3.1 Running the engine when vehicle stationary	A35
3.2 Mounting of power take-offs and flanged pumps	A35
3.3 Front power take-offs (crankshaft nose) (except RENAULT PREMIUM / KERAX)	A36
3.4 Front and rear power take-offs	A36
3.4.1 Propeller shaft alignment	A36
- Angularity criteria	A36
- Angular acceleration criteria	A37
- Transversal stress criteria for prop shaft tubes and bearings	A37
3.4.2 Propeller shaft balancing	A38
3.4.3 Maximum permissible length of a prop shaft as a function of the rotating speed	A38
3.5 Vehicle driveline (powertrain)	A38
3.6 Mounting of handling cranes	A39
3.6.1 Mounting on the sub-frame	A39
3.6.2 Graph of the moment of inertia of the sub-frame as a function of the lifting torque	A40
3.6.3 Crane in the rear overhang	A41

3.7 Tail lifts	.A42
3.7.1 Sub-frames	.A42
3.7.2 Attachment	.A42
3.7.3 Electrical connections for a tail lift	.A42
3.7.4 Special recommendations for tail lifts from 1500 to 2000 kg without landing legs	.A42
3.7.5 Graph of the moment of inertia of the sub-frame as a function of the lifting torque	.A43
3.8 Sub-frame box sections	.A44
3.9 Fitting of specific equipment	.A44
3.9.1 Electrical connections	.A44
3.9.2 Installation of receivers or generators with a voltage of more than 24 V	.A44
3.10 Tapping on the diesel fuel tank	.A44
3.11 Fifth wheels	.A45
3.11.1 Mounting standards	.A45
- Kingpin 50 mm (2") dia.	.A45
- Kingpin 90 mm (3.5") dia	.A45

CHAPTER -B- RENAULT MAGNUM E-TECH SPECIAL BODYBUILDING FEATURES

1. PRESENTING THE “RENAULT MAGNUM E-TECH” SERIES	.B3
1.1 Electronic management of “RENAULT MAGNUM E-TECH” vehicles	.B5
1.1.1 Operating principle	.B5
1.1.2 Bodybuilders’ electrical pre-arrangements	.B6
1.2 Warning	.B6
2. GENERAL REMARKS ON THE “RENAULT MAGNUM E-TECH” SERIES	.B7
2.1 Identification of the vehicle	.B7
2.2 General drilling principles	.B8
2.2.1 Drilling cab panels for fitting accessories	.B8
2.2.2 Drilling in sidemembers	.B9
- Anti-corrosion protection and paint retouches to the chassis	.B9
2.3 Precautions prior to welding	.B10
2.3.1 Protection of wiring harnesses	.B10
2.3.2 Welding on vehicles equipped with a master switch	.B11
2.4 Minimum load on front axle	.B13
2.5. Soundproofing screens and heat shields	.B13
2.5.1 Instructions for soundproofing screens	.B13
2.5.2 Instructions for heat shields	.B13
2.6 Side impact guards	.B13
3. INSTALLATION OF BODYWORK	.B14
3.1 Use of 1/20th scale drawings and calculation sheets	.B14
3.2 Sub-frame sections	.B14
3.2.1 Sub-frame minimum height	.B14
3.2.2 Sub-frame minimum inertia	.B14
- Reminder of formula for calculating maximum normal surface stress	.B14
3.3 Lateral guiding	.B15
- Inertia stop	.B15
3.4 Attachment of bodywork	.B16
3.5 Attachment of sub-frames to brackets	.B17
3.5.1 Types of fastening	.B17
- Guiding and fastening zone	.B17

3.5.2 Vertical positioning of brackets	.B20
3.5.3 Longitudinal positioning of brackets on chassis	.B21
3.6 Vertical exhaust	.B26
4. ELECTRICS	.B29
4.1 Available power supplies	.B29
4.2 Electrical pre-arrangements	.B32
- Electrical diagram for standard available power supplies	.B33
- Key	.B36
- Assignment of fuses concerning electrical pre-arrangements	.B36
- Fuses and relays connection unit "BFR"	.B37
4.3 Management of engine speed	.B38
4.4 Power take-off wiring	.B38
4.4.1 Vehicle fitted with one PTO	.B38
- A) Determining the rotating speed	.B38
- B) Using the chassis-mounted fast idling variable speed control	.B38
- C) Controlling speed regulation without cruise control	.B39
4.4.2 Vehicle fitted with two PTOs	.B39
- A) Determining the rotating speed	.B39
- B) Using the chassis-mounted fast idling variable speed control	.B39
- C) Controlling speed regulation without cruise control	.B39
4.4.3 Vehicle fitted with three PTOs	.B40
- A) Determining the rotating speed	.B40
- B) Using the chassis-mounted fast idling variable speed control	.B40
- C) Controlling speed regulation without cruise control	.B40
4.4.4 Vehicle fitted with one engine rear PTO or no PTO at all	.B40
- A) Determining the rotating speed	.B40
4.5 Use of the steering wheel fast idling fingertip control	.B41
4.5.1 Vehicle fitted with one power take-off	.B41
4.6 Engine speed information	.B42
4.7 Trailer sockets	.B43
4.8 ADR regulation for vehicles equipped with independent (add-on) heating	.B44
5. FAST IDLING DEVICE	.B45
- Electrical diagram for lateral lights	.B46
- Key	.B48
- Assignment of fuses	.B48

CHAPTER -C-

SUPPLEMENTARY INFORMATION ON THE "RENAULT MAGNUM E-TECH" VEHICLE

1. MOUNTING OF POWER TAKE-OFFS	.C3
1.1 Gearbox-mounted PTO	.C3
1.1.1 Instructions for the assembly of auxiliary hydraulic pumps to ZF type "C" PTOs (ZF or HYDROCAR)	.C5
1.1.2 Calculation of the weight torque	.C5
1.1.3 Fastening the hydraulic pump	.C5
2. AIR-OPERATED EQUIPMENT	.C6
2.1 Connection of extra auxiliary equipment	.C6
2.2 Table of compressors	.C6

3. ELECTRICS	C7
3.1 Cab earths	C7
- Driver's door and top side ledge earths	C7
- Passenger's door and top side ledge earths	C8
- Cab floor earths	C9
- Cab front end earth	C10
- Attachment of earthing lug or braid to cab	C11
- Assembly to electrical earth points diameter 11 mm	C11
- Assembly to electrical earth points diameter 13 mm	C11
3.2 Chassis earths	C12
4. CHASSIS	C13
4.1 Sidemember steel classes	C13
4.2 Sidemember sections	C13
4.3 Reinforcement, extension, shortening of sidemembers in the rear overhang	C13
4.3.1 Modification to the wheelbase	C14
4.4 Intermediate cross-member	C14
5. ASSEMBLY OF EQUIPMENT TO CAB	C15
5.1 Installation of air horns	C15
5.2 Installation of CB radio antenna	C16
5.3 Installation of radio antenna and telephone antenna	C17
5.4 Installation of roof deflector	C18
6. AIRBAG	C19

CHAPTER -A- GENERAL FEATURES

IMPORTANT

General principles and basic rules applicable for the conversion and fitting of equipment to vehicles in most cases for the majority of applications are detailed in this "General features" chapter.

1. GENERAL FEATURES

1.1 Scope of liability

RENAULT TRUCKS vehicles are merchandized at the end of corroborated technical designwork and endurance testing, taking the various laws, regulations, standards... involved into consideration.

Modifications to a RENAULT TRUCKS vehicle for the fitting of bodywork and equipment should be carried out in accordance with the rules and recommendations set out in this bodywork fitting guide and require an "Agreement in Principle", issued by the Product Applications Department.

Guarantee and responsibility

Any intervening party is responsible for his services in terms of guarantee and responsibility, including any damage caused by his work and/or the equipment installed on-vehicle or the basic product.

In the event of RENAULT TRUCKS (or its network) being prime contractor for its own equipment (in relation to the end customer), the guarantee is considered as being at least that of the warranty offered by RENAULT TRUCKS to its customer.

Unless clearly specified otherwise in the order, the equipment warranty shall be negotiated directly between the end customer and the equipment manufacturer.

The meeting of recommendations contained in the present document can in no way be considered as relieving the equipment manufacturer's responsibility, but simply as complying with the basic rules for professional trade practice.

Any breach of these recommendations must be considered as shortcoming in respect of the rules and shall relieve RENAULT TRUCKS of its liability in the event of damage connected directly or indirectly to such non-compliance.

All the equipment is considered to comply with these recommendations and shall not require any acceptance testing upon delivery to check the conformity.

RENAULT TRUCKS guarantees non-modified original parts and components.

Interventions, conversions, adaptations of fittings carried out by the intervening party involves his responsibility, even if they are authorized administratively (Conversion appendix II).

Such conversions must not under any circumstance lead to any impairment of the quality or of the primary functions of the component elements of the vehicle (whether these elements are affected directly or not by the intervention).

Any modification, changing of position of constituent vehicle parts or elements must be covered by an "Agreement in Principle", issued by the RENAULT TRUCKS Product Applications Department.

For further information or assembly agreement, contact:

TO OBTAIN ANY INFORMATION OR APPROVAL OF MOUNTING, PLEASE CONTACT:

For France:

SERVICE TECHNICO-COMMERCIAL

RENAULT TRUCKS

API. COM 00A 238

69806 ST PRIEST CEDEX

Tel.: 04 72 96 68 14

Telex: 300 265 UDCF +

Fax: 04 72 96 81 93

For the United Kingdom:

Product Applications Department

RENAULT TRUCKS UNITED KINGDOM

Boscombe Road,

Dunstable

Bedfordshire LU5 4LX

Tel. (Switchboard): (+44) (0)1582 471 122

Fax (Marketing) (+44) (0)1582 479 146

1.2 Regulations

The bodybuilder must meet:

- the different European and/or destination country laws, regulations and standards governing driving and vehicle building,
- the stipulations of the Highway Code and its various amendments and appendices,
- the different laws, regulations and standards governing road traffic in force in the country of destination.

The scope of this compliance must cover:

- Lighting and signalling,
- Weight and dimensions,
- The field of vision and rear view,
- The regulation protection devices (e.g. side guards, anti-spray, run-under guard),
- The hitch coupling and towing systems, (compliance with standards and regulations),
- Specific clauses concerning the transport of dangerous goods (ADR, COSHH etc.),
- Sun-roofs,
- Pollution control standards,
- Electromagnetic compatibility standards for electronic equipment.

1.3 Safety

All components having an influence on:

- The control of the driver of the trajectory and the ability to stop the vehicle and its trailer,
- The load distribution on the front or the rear, the left or the right,
- The risk of fire,
- and any other risk for the vehicle and its surrounding environment.

Among the components, we would mention, among others:

- The cab tilt mechanism,
- The wheels (tightening of the nuts),
- Seats and seat belts (anchorage points),
- The attachment of bodywork or equipment to be in conformity with the technical instruction document in force, (i.e. the Guide for the Fitting of Bodywork),
- The hitch coupling and towing systems, (i.e. anchorages),
- Electrical systems (protection of circuitry, the electrical rating, attachment, conformity of the connections with the technical instruction document, (i.e. the Guide for the Fitting of Bodywork),
- Warning systems and driver information systems, (i.e. no interference with the information given by the instrument panel on the dashboard),
- Information for use affixed by the manufacturer to the vehicle (i.e. decals for tilting of the cab, drilling points, welding points, batteries, etc.)
- Extension and reduction of the length of the wheelbase and the rear overhang.
- Re-location or replacement of the cross-members.
- Circuits for ancillary equipment.

In order to guarantee the safety and the satisfactory operation of the vehicle, modification of the following components is strictly forbidden:

- Brakes: circuits, controls and anchorages,
- Steering: circuits, controls, anchorages and geometry,
- Axle and axle housing assemblies,
- The air-bag system and pretensioning systems on the seat belts,
- The electronics.

1.4 Quality assurance

Our permanent objective is to give satisfaction to our customers and we must achieve this in full on the final product consisting of a chassis, bodywork and/or an item of equipment.

In order to achieve this objective, RENAULT TRUCKS expects from all those co-operating with it in the field of mounting bodywork and equipment supply to implement a Quality Assurance System.

RENAULT TRUCKS can demand proof for the execution of all bodywork, the fitting of equipment or modification of a basic truck, in accordance with Standard ISO 9000, of:

- The conformity with all legislation, EC Directives and national regulations,
- The compliance with the manufacturers' directions,
- The control of quality of the execution of the work.

This is done with the knowledge that, on the face of it, the vehicle is considered as complying with the whole of the regulations.

1.5 Documentation

In all cases involving equipment, the installer is obliged to supply a manual covering the use, service, maintenance and safety of his installation.

1.6 General instructions

When building and fitting a body (including such equipment as rear run-under guards), a certain number of requirements and a certain number of vital requirements specific to each type of vehicle must be taken into consideration. These various points relate to maintenance, accessibility and the circulation of fluids.

Examples:

- Ease of access to the various maintenance and lubrication points, to the fuel tank and fuel gauge, to the batteries and the various electrical terminal boxes.
- The ability to easily dismantle the various component parts of the transmission and the suspension.
- Access to the circuits for air-intake, exhaust, and fuel supply.
- Taking into account the wheel movement detailed on the bodywork drawing (i.e. take care to allow for snow chains; extra clearance must be provided).
- Ventilation of the brake drums and discs and the battery compartment.
- The radiator inlet and outlet areas, which must not be modified.
- Full compliance with the dimensions and weights specified in our technical documents. Under all circumstances, the bodybuilder must ensure free movement and safe operation of all the moving component parts of the chassis (i.e. springs, prop shaft, etc.)
- The addition of a body must not affect the vehicle running and driving safety. Take care to ensure that a balanced distribution of the loads on the right and the left hand sides of the vehicle is obtained.
- For any bodywork installation, a calculation of load distribution must be made for each axle, in order to check that the weight imbalance between the right and the left hand side is below 4%.
- The flow of the coolant must be maintained at all times. It is, therefore, not allowed to blank off, even partially, the air intakes provided (on the radiator grille or the front end). Orange ADR or similar "Hazardous Substances" plates should be affixed to solid surfaces (i.e. without vent holes).

On the arrival of a vehicle in your workshop for body fitting, we recommend that you should check one hour after the arrival of the vehicle, the state of charge of the batteries.

Voltage at the battery terminals		Specific gravity of the electrolyte	State of charge
6 Volt battery	12 Volt battery		
6.3 Volts	12.7 Volts	1.27	100 %
6.2 Volts	12.5 Volts	1.24	80 %

During the period for the fitting of the bodywork, you should particularly check that:

- The vehicle is not run without a battery.
- Do not move the vehicle on the starter motor.
- Do not use a booster starter.
- Ensure that the tyre pressure is checked and tyres inflated to the correct value where necessary.
- Protect body components or items of trim against all damage.
- Refit the original batteries, where these have been taken off.

IMPORTANT

- Whatever work you are doing on the vehicle, you must switch off the electrical circuit at the master switch or by disconnecting the batteries in order to avoid any risk of electric shock during work.
- When a vehicle is laid up (i.e. at a standstill for longer than 10 days), disconnect the electrical circuit by removing the fuse or by the circuit-breaker so as to avoid discharge of the batteries through the tachograph.

The information contained in this manual is only applicable to bodywork in steel. For aluminium bodies, refer to the Product Applications Department of RENAULT TRUCKS.

It is forbidden to weld, grind, cut up, drill or heat the sidemembers or cross-members unless the contrary is clearly stated. These operations may only be carried out in conformity with the recommendations laid down in the present document.

Any special case, any bodywork fasteners and fittings not described in this manual must be submitted for our approval prior to use.

Before commencing the fitting of any bodywork, you must consult:

- The Vehicle Technical Data Sheet,
- The bodybuilders drawing and the relevant calculation sheets which relate to the body to be fitted,
- The vehicle driving and maintenance handbook.

If you do not have these items available, you should obtain them from RENAULT TRUCKS Dealers or the Product Applications Department.

In the technical manual and on the bodywork drawing is stated the permitted maximum and minimum length of body; we would strongly advise you to stay within these limits.

Furthermore, it should be noted that the changing of position of a component such as spare wheel, tank, etc., the modification of a chassis without uniform weight distribution or the fitting of an over-cab extension, causes a modification of the load distribution of a fully equipped chassis in every single case.

Modification to load distribution must be compensated for by an alteration in the permitted length for bodywork. It then becomes necessary to calculate the new position of the centre of gravity of the bodywork.

The weights specified in our technical data sheets refer to standard vehicles, ready for the road, without optional extras.

Furthermore, the weight of chassis cab is given with a tolerance of plus or minus 4%.

Optional equipment such as reinforced springs, power take-offs, different tyre fitments, will cause an increase in weight for the basic chassis.

For these reasons, when weighing the chassis cab, bodybuilders should weigh:

- The front axle(s),
 - The rear axle(s),
 - The complete vehicle,
- without driver, without passenger, but with full fuel tanks and with vehicle on-board tool kit.

For the preparation and attachment of the various types of bodywork, it is preferable not to take off the wheels, unless absolutely necessary.

Nevertheless, you must take the precautions set out below:

- It is forbidden to paint the bearing surfaces of the wheel rim hubs and the seating for wheel nuts.
- During fitting, make certain that the parts are perfectly clean prior to fitting.
- Tighten the wheel nuts to the torque recommended (cf. vehicle driving and maintenance handbook)

Installation fitted with key-operated locks: the section of such keys must be very different to that used for the vehicle keys. Indeed, these keys should not be able to be put into the vehicle locks by mistake, thus avoiding any risk of damage to the barrels of the locks.

1.7 Safety on tilt cabs

After the conversion of standard cabs by the bodybuilders, (i.e. extension, bunk adaptation, over-cab extension, etc.) because the weight distribution has changed, the tilt system may no longer meet the requirements of the safety standards.

Under these circumstances, and without prior agreement from the manufacturer, the full and entire responsibility rests with the bodybuilder.

1.8 Chassis markings

The identification number of the vehicle is on the sidemember (refer to the vehicle driving handbook).

The identity markings of the vehicle must remain visible and accessible without having to remove any part of the body.

1.9 Adjustments to the vehicle settings

Under no circumstance may bodybuilder or converters make any alteration to the original settings of RENAULT TRUCKS vehicles.

1.10 Cleaning

1.10.1 Bodywork

So as not to cause any damage to the condition of the paintwork and the seals:

- Avoid using a high temperature jet of steam.
- Restrict the use of brushes. They must be in good condition and well maintained.
- We advise against the use of brushes, during the first month of vehicle use.
- If you are using a high pressure jet wash unit, limit the pressure to 80 bars maximum.
- Keep the lance well away from the bodywork; do not spray fluidtight joints.
- Use neutral soap based products.
- In order to remove grease spots, use cleaning fluid (not petrol).
- Parts in aluminium must be cleaned with water to which a non-alkaline washing product has been added, and rinsed with clean water.
- Spread a coat of Vaseline or talcum powder over the seals.

1.10.2 Chassis/Underbodies

Use a high pressure unit. Limit the pressure of the jet to 80 bars maximum and the time of use to the strict minimum necessary.

In order to prevent any risk of a problem, do not spray:

- electronic or electrical boxes,
- the seals of link rods,
- hinge pins,
- air inlets for the heater, the engine air intake and air filter,
- pneumatic and electrical apparatus,
- absorbent materials and soundproofing screens,
- the fuel gauge.

1.10.3 Cleaning of the cab

Spray lightly or use a cloth dipped in a cleaning agent (i.e. soapy water, methylated spirits, etc.). Products with a petroleum and trichlorethylene base are not to be used.

Spread talcum powder lightly onto the door seals and the windows, as well as any link rods.

1.10.4 Cleaning of the instrument panel

Only use soapy water. Any other product is not allowed.

1.11 Safety and protection of components

Before any operation of grinding, drilling, or welding, ensure that the following are effectively protected or taken off:

- Plastic pipework and tubes,
- Electrical wiring harnesses,
- Suspension springs (particularly for the protection against corrosion),
- The bags for the air suspension,
- The soundproofing screens,
- Any other component sensitive to heat, to the discharge of incandescent matter, to ultraviolet rays (i.e. electronic control units, electronic components, items in plastic material, flexible anti-vibration mountings, painted items, etc.),
- For welding work, comply with the other recommendations described in the chapter entitled "Protection of electrical and mechanical components".

1.12 Summary of definitions

Maximum body length (Dimension W on technical data sheets and bodywork drawings).

This is the bracket of lengths for bodies (not including fittings and accessories) worked out in relation to the extreme positions of a given centre of gravity for a load which is taken to be evenly distributed and taking into account the space which must be left to the rear of the cab, laid down by the manufacturer, and the maximum permitted loads per axle on a chassis cab without options.

Body start (Dimension B on technical data sheets)

Minimum distance between the front axle centre-line and the front end plane of the body.

Load distribution calculations

Comply with the regulatory constraints for each country and the load limits given per axle for each model by RENAULT TRUCKS.

We remind you that these values are given for uniformly distributed loads.

The lateral imbalance of the loads should not exceed a maximum of 4% between the LH and RH roadwheel of each axle.

Chassis rear overhang (Dimension N on technical data sheets)

Horizontal distance between the centre-line of the rear roadwheels and the rear extremity of the body (excluding fittings and accessories).

In the case of vehicles with 3 or 4 axles: distance between the centre-line of the rearmost axle and the extremity of the chassis.

Body rear overhang (Dimension X on technical data sheets)

Horizontal distance between the centre-line of the rear roadwheels and the rear extremity of the body (excluding fittings and accessories).

In the case of vehicles with 3 or 4 axles: distance between the technical centre-line of the tandem and the rear extremity of the body.

Wheelbase (Dimension F or F' on technical data sheets).

Distance between the centre-lines of the front and rear roadwheels (vehicle laden).

In the case of vehicles with 3 or 4 axles: distance between the centre-line of the front roadwheels and the centre-line of the foremost rear axle - for calculations take dimension F' (technical wheelbase).

Tandem

Solely in the case of vehicles with 3 or 4 axles: the 2 rear axles taken together, regardless of whether they are driving axles or trailing axles.

Maximum axle weight

Carrying weights are stipulated on each axle for each type of vehicle. These values are indicated on the technical data sheets and on the VIN plate and must be complied with on all vehicles fitted with bodies when laden and when empty.

Driver and cab passengers weight

The weight of the driver and passenger (passengers) in the cab is applied to the front axle in the case of a forward control cab.

For cabs of the semi-forward control type, 2/3 of the weight should be applied to the front axle and 1/3 to the rear axle.

Weight of driver or each passenger: 75 kg (calculated on the basis of the cab seating capacity), unless stipulated otherwise: i.e. Export, Army, Fire Brigade, etc.

For cabs with a seating capacity of more than 3 persons, calculate the weight distribution of the persons on the basis of the seats layout.

For equipment intended for the Army or for Civil Administrations, take the specific specifications into account.

1.13 Certificate of approval of the conversion of a vehicle

1.13.1 Application for approval

- 1** If the body or the equipment fitted do not modify the weight and dimensional characteristics of the chassis entered in the descriptive sheet, the vehicle can be submitted to the Type Approval Department without any action by RENAULT TRUCKS being necessary (within the permitted limits in force).
- 2** The maximum rear overhang is equal to 60% of the wheelbase. However, for special cases, we can grant higher percentages - for this, consult us.
- 3** If the layout requires modification to the wheelbase, it is essential to consult the Product Applications Department. Each case has to be covered by a specific design.
- 4** The certificate will be issued in accordance to the legislation in force regarding modifications made by and under the responsibility of the bodybuilder, within the limits stipulated by the Manufacturer and relative to:
 - the wheelbase
 - the distribution of loads
 - the cab characteristics.
- 5** For more accuracy in your calculations, we recommend you to introduce into the data the weighed weight of the chassis cab to be equipped (capable of varying according to manufacturing tolerances and the various options available). The same applies to equipment for which the manufacturers can accurately define the weight and the position of the centre of gravity.

1.13.2 Body fitting certificate

This defines the installation of the equipment on the chassis cab and the unladen weight imposed on the axles and then the weight when fully laden.

It must be attached to all applications relating to the equipment which do not comply with any of the dimensions set out in the descriptive sheet.

1.13.3 Responsibility for installation

The building and fitting of a body on a vehicle is the sole responsibility of the bodybuilder, who must comply with the recommendations in the present document.

He must ensure that the installation of the body does not affect the functions or the reliability of the components or the road behaviour of the vehicle.

1.14 Painting

1.14.1 Precautions

- Protect the RENAULT TRUCKS equipment (i.e. by using screens, self-adhesive tape, cab cover etc.)
- Never put vehicles into drying ovens at a temperature of more than 80° C.
- The chassis of the vehicle must be electrically earthed to allow static electricity to run away to earth (protection of electronic boxes).
- The vehicle must be protected against corrosion by paints compatible with those used by our Company and conforming to RENAULT TRUCKS Specification No 4702 441 (protection of bodywork and equipment adapted to RENAULT TRUCKS vehicles) available from the Product Applications Department.
- Thinner solvents must never be used on cables and electrical sheaths.
- Protect the identification marking of electrical wires and compressed air pipes.

Never paint bearing surfaces of brake drums and disc wheels, or with twin tyre fitment, the assembly surfaces between the disc wheels. As a general rule, do not repaint the support surfaces of original fitment nut and bolt hardware and comply with the specification.

NOTE

Our Product Applications Department holds the reference numbers for paint colour shades for chassis and cabs at your disposal. These paint colours can be procured as "spare parts" and can be ordered from our dealers.

The cab colour shade is indicated on the front end of the cab.

Since 1994, chassis and accessories are no longer sprayed with the customer's shade of paint at the time of original fitment.

To preserve the aspect and original quality, it is essential to observe the following methods after fitting equipment, body, sub-frames and various adaptations to major units or chassis frame:

1.14.2 Major units (gearboxes, drive axles, engines, axles, etc.)

Works paint: GLYCEROPHTHALIC

Retouch (after fitting PTO, charge indicator, etc.)

Retouch method

- Clean with a universal cleaner or using a high-pressure cleaner.
- Wipe down, then apply a primer.
- Let the product cure until mat (about 15 minutes at 20° C), then apply the corresponding polyurethane lacquer.

1.14.3 Chassis frame and accessories (sidemembers, cross-members, fittings, lockers, etc.)

Works paint: POLYURETHANE or POLYESTER powder.

Retouch method:

Superficial scratches (the metal is not affected).

- Clean with a universal cleaning product.
- Wipe down, then apply the corresponding undiluted but catalyzed polyurethane lacquer, using a small brush.

Deep and fine scratches (down to the bare metal).

- Clean with a universal cleaning product.
- Wipe down, then apply the primer, using a small brush.
- Let the product cure (about 15 minutes at 20° C), then apply the corresponding undiluted but catalyzed polyurethane lacquer.

Deep and wide scratches (down to the bare metal, drilling of sidemembers for attaching tail lifts and accessories) due to drilling.

- Rub down.
- Clean with a universal cleaning product.
- Let the product cure until mat (about 15 minutes at 20° C), then apply the corresponding polyurethane lacquer.

Making good after conversion (after converting wheelbase and overhang).

- Grind, rub down; prepare the area in question (burnt paint, welding scale, etc.).
- Clean with a universal cleaning product or using a high-pressure cleaner.
- Mask with tape (electrical wiring harnesses, air and fuel pipes, labels, etc.)
- Wipe down, then apply the primer.
- Let the product cure until mat (about 15 minutes at 20° C), then apply the corresponding polyurethane lacquer.
- After drying, put back the electrical wiring harnesses, air and fuel pipes and accessories.

Spraying chassis and accessories (with customers colour shade).

- The bodybuilder undertakes to preserve the aspect and quality of the original fitment vehicle (except for nut and bolt hardware).
- Clean with a universal cleaning product or using a high-pressure cleaner.
- Mask with tape (electrical wiring harnesses, air and fuel pipes, labels, etc.)
- Wipe down, then apply the primer.
- Let the product cure until mat (about 15 minutes at 20° C), then apply the corresponding polyurethane lacquer.
- After drying, put back the electrical wiring harnesses, air and fuel pipes and accessories.

NOTE

All spray gun operations are to be carried out in a painting booth.

Since August 1999, the chassis are painted grey as replacement for Enduro red. For paint retouches on grey chassis, use a grey paint aerosol ref. N° 50 01 848 147.

1.14.4 Recommended products

Manual cleaning

Universal cleaning product or equivalent solvent

Products approved by RENAULT TRUCKS

Supplier	Commercial name	RENAULT TRUCKS Ref.	Supplier Ref.
BASF	PK 900	50 01 821 758	SV 20023F
ICI AUTOCOLOR	Slow Spirit Wipe	50 01 854 983	P850-1402
STANDOX	ENTFERNER Agent	50 01 825 985	FA 931 2002

High-pressure cleaning

Degreaser, phosphater degreaser

Filling and sealing

Products approved by RENAULT TRUCKS

Supplier	Commercial name	RENAULT TRUCKS Ref.	Supplier Ref.
STANDOX	"EPOXY" filler-sealer	50 01 826 019	FA 931 5203
	"EPOXY" hardener	50 01 825 990	FA 931 5204
	"EPOXY" thinner	50 01 826 005	FA 931 5205
	"EPOXY" slow thinner	50 01 829 256	FA 931 5213
	thinner 2KS	50 01 825 992	FA 020 7810
ICI AUTOCOLOR	"EPOXY" filler-sealer	50 01 829 477	P580-2100
	"EPOXY" hardener	50 01 829 480	P210-833
	thinner	50 01 829 481	P850-3091

§Finish paint

Two-component polyurethane paint and corresponding thinner.

1.14.5 Marking of polymer components (recycling of plastics)

Plastic parts are marked so as to simplify their sorting during recycling at the time when the vehicle is scrapped at the end of its life.

Marking of the plastic parts is done by placing abbreviated terms for the polymer components between the symbols ">" and "<". The parts are marked on a face which the customers cannot see and when it is possible the marking is indelible. Marking is done in the following manner:

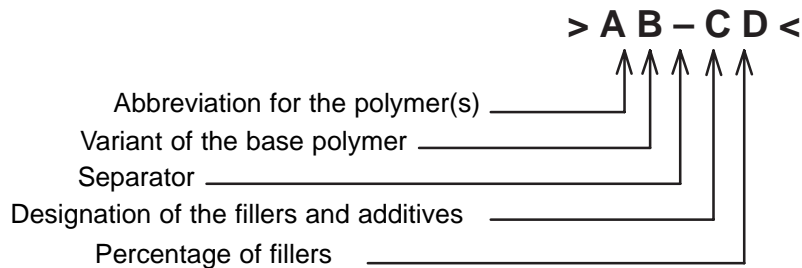

Marking of single component products

The abbreviated term for the material is enclosed in symbols ">" and "<".
For example: ">PP<" or "PP" indicates polypropylene.

Marking of copolymers

The abbreviated terms for the polymers are separated by a "/".
For example: ">P/E<" indicates the copolymer propylene ethylene.

Marking of mixtures or blends of polymers

The abbreviated terms are separated by a "+" (heterogeneous structure).
For example: ">PP + EPDM<" stands for a blend of polypropylene and EPDM.

Marking of polymers with fillers (additives)

The abbreviated term for the polymer is separated from that for the filler by a dash "-".
The number following the abbreviated term for the filler relates to its percentage in the mixture.
For example: ">PA66 - (GF25 + MD15)<" indicates polyamide 66 with 25% filler and 15% reinforcement with mineral fillers (in decreasing order of percentage).

Marking of multi-component products

The abbreviated terms for the components are separated by commas, in order of appearance (firstly the surface material).
For example: ">PVC, PUR, ABS<" indicates skin surface PVC on PUR foam with an ABS insert.

Marking of special features

Abbreviated terms for the polymers can be added up to 4 symbols, in order to indicate a modification.
The symbols are put in after the abbreviated terms.
For example: ">PE - C<" indicates chlorinated polyethylene, ">PE - LLD" stands for linear low density polyethylene.

Table of the principal polymers

Abbreviated term	Variant	Materials
A.B.S		Acrylonitrile/butadiene/styrene
A.S.A		Acrylonitrile/styrene/acrylate
E/P		Ethylene/propylene
E.P.D.M		Copolymer ethylene/propylene/diene
P.A		Polyamide
P.A	6	Polyamide 6
P.A	66	Polyamide 66
P.C		Polycarbonate
P/E		Propylene/ethylene
P.E		Polyethylene
P.E	– HD	High density polyethylene
P.E	– LD	Low density polyethylene
P.E	– LLD	Linear low density polyethylene
P.E	– X	Cross-linked polyethylene
P.M.M.A		Poly(methacrylate of methyl)
P.O.M		Polyoxomethylene
P.P		Polypropylene
P.P.E		Poly(phenylene ether)
P.P.O.X		Poly(oxide of propylene)
P.S		Polystyrene
P.S	– HI	Impact polystyrene
P.T.F.E		Poly(tetrafluoroethylene)
P.U.R		Polyurethane
P.V.C		Polyvinyl chloride
P.V.C	– C	Chlorinated polyvinyl chloride
P.V.C	– P	Plasticized polyvinyl chloride

1.15 Electrical equipment

1.15.1 General

- Any mounting of a specific item of equipment on a commercial vehicle must be in conformity with the recommendations of RENAULT TRUCKS and the legislation in force. Its execution remains the entire responsibility of the bodybuilder, both with regard to the suitability for the vehicle being equipped and any possible electromagnetic interference.
- For reference to wiring diagrams, consult the electrical equipment workshop manual for the vehicle (available from the Spare Parts Department of RENAULT TRUCKS).
- Check that the electrical consumption of this equipment is appropriate for the capacity of the batteries and also the charging current rate of the alternator (if not, refer to the recommendations of the manufacturer CIC 1081). For the fitting of any particular equipment, consult the Product Applications Department of RENAULT TRUCKS.
- A schematic diagram should be submitted for the approval of RENAULT TRUCKS, when raising any specific question.
- A wiring diagram for the bodybuilder's or equipment manufacturer's installation must be incorporated into the vehicle driving and maintenance handbook. The electrical connection points for the equipment being supplied should be clearly and precisely indicated on this wiring diagram (even after the agreement of RENAULT TRUCKS has been obtained).
- Follow the electrical protection recommendations of RENAULT TRUCKS; it is forbidden to change the rating of fuses.
- In order to harmonize vehicle equipment, you should use in preference such items as are identical to those fitted in the basic vehicle (i.e. indicator lamps, controls, relays, etc.).
- Assembly of a protective shield on the electric retarder is compulsory for ADR (Transport of Hazardous Substances) vehicles (refer to regulations in force).
- It is compulsory for the supply voltage for the equipment installed to be equal to the rated voltage of the vehicle. The installation of equipment with a 12 volt power rating on our vehicles (24 volt rated voltage) is not permitted unless a voltage dropper is added.
- Under the circumstances that additional lamps are fitted, the installation must not damage the fluidtight sealing of the junction boxes.
- Operating without a battery is forbidden.

1.15.2 Wiring harnesses

- Use to the full the wiring runs already set up by the manufacturer (i.e. conduits, tubes, sleeves, etc.) and comply with the limit of their capacity.
- Any wiring harness added by the bodybuilder must be protected by a sealed sheath (smooth and thick or ringed) and can be routed along with the original wiring runs for the vehicle provided that it does not adversely affect the mechanical mountings for the original harnesses. For vehicles for the transport of hazardous goods, use the protective equipment authorized by the regulations covering the transport of hazardous goods.
- If you are obliged to route wires close to a source of heat (i.e. engine, exhaust system, etc.), the minimum clearance to be complied with is 200 mm.
- Never route a wiring harness over projecting angles.
- Never attach a wiring harness to moving parts (even slight movement).
- The section of the cables being used must be suitable for the use in question. Their cross-section should be selected in accordance with the maximum current on-line (5 amperes per mm²).
- The length of the wiring harnesses should be long enough to allow the electrical appliance which is connected to be taken off (i.e. principal display unit, tachograph, etc.).
- The numbering of the wires must be in accordance with the manufacturer's standard.
- The link between the sheath and the connector must be fluidtight.

1.15.3 Electrical connections

- Any additional connection requires protection that is suitable for the use for which it is intended (even if the power supply provided for the customer by RENAULT TRUCKS is already protected by a fuse).
- Any electrical connection must be properly wired on the power lines supplied by the manufacturer to the bodybuilder's equipment (refer to the servicing and maintenance handbook for the vehicle in question).
- Tapping into the various wiring harnesses supplied by RENAULT TRUCKS is completely FORBIDDEN (for example vehicle rear lamps, external marker lamps, contactors, pressure switches, relays, electronic box inputs and outputs, etc.)

Reminder: a 12 V tapping at the middle point between the two batteries is strictly FORBIDDEN.

- The electrical connections of the various wiring harnesses of the bodybuilder must be made using a fluid-tight junction box or otherwise using sealed connectors. If connections have to be made on circuits hooked up to electronic equipment:
 - Ensure that you comply with the polarity recommended.
 - No inductance current must pass through the circuits which have been added.
 - All the earths must be connected up to the available "EARTH" points provided and not to the bodywork of the vehicle.
 - After work on junction boxes, the seal must always be as integrally effective as the original seal.
 - Any power supply requiring a direct connection to the batteries must be capable of being isolated by a battery cut-out (for example: tail lifts) and protected by a fuse sited as near as possible to the batteries. Suitable connection terminals should be used.
 - The + power supply is taken from the master switch, or failing this, from the battery terminal for vehicles without a master switch, but in no case from the alternator or starter motor terminal.
 - Power supplies to auxiliary equipment: i.e. telephone, fax, etc. The quality of the installation is the responsibility of the installer (i.e. reception, static, interference, etc.)
 - Preferably, you should use connectors approved and distributed by RENAULT TRUCKS (i.e. type, sealing properties, rating, number of channels, etc.)
 - Connectors for equipment should be positioned near the bottom, whilst avoiding areas subject to splashing (i.e. wheelarches, etc.).

1.15.4 Available power supplies

All our vehicles are equipped with the available power supply protected by fuses and these are at the disposal of bodybuilders and equipment manufacturers.

These power supplies are described in the vehicle driving and maintenance handbook (supplied with every vehicle), in the Workshop Repair Electrical Manual, and in this document (all these documents are available from the RENAULT TRUCKS dealer network).

1.15.5 Flasher units

Should the flasher unit become inoperative due to failure to comply with the instructions contained in this document, the coverage granted by the warranty will be lost.

The flasher units are designed for a maximum rating which is marked on the unit.

Do not exceed this power rating.

Connection

In order to make the connections correctly, consult either the identification marks which are located close to the terminals, or the wiring diagram on the label which is affixed to the flasher unit cover.

1.15.6 List of standard power sockets

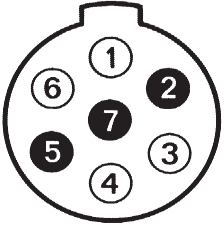
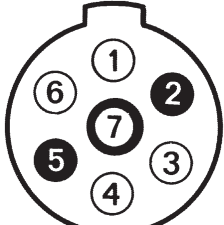
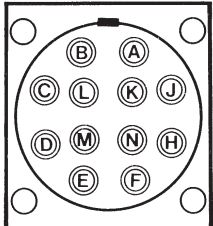
SUPPLY VOLTAGE	DESCRIPTION AND STANDARDS	SOCKET DIAGRAM (front view)
12 Volts	<p>12 N type socket (Standard: - BNA.R.43.407 dated April 1982 - ISO 1724).</p> <p>1 - LH direction indicator lamp. 2 - Rear fog lamp. 3 - Earth. 4 - RH direction indicator lamp. 5 - RH rear side and marker lamp and number plate illumination lamp. 6 - Stop lamp. 7 - LH rear side and marker lamp and number plate illumination lamp.</p>	 <p style="text-align: center;">600037</p>
12 Volts	<p>12 S type socket (Standard: - BNA.R.43.410 dated August 1982 - ISO 3732).</p> <p>This is a supplementary socket which is assembled in addition to the 12 N socket.</p> <p>1 - Reversing lamp. 2 - Not allocated. 3 - Earth. 4 - Supplementary + power supply. 5 - Earthing monitor. 6 - Positive (+) power supply. 7 - Not allocated.</p>	 <p style="text-align: center;">600038</p>
24 Volts	<p>12-pin socket (Standard: - BNA.R.43.405 dated March 1961 - DEFA 1457 b - DCEA 5.556 - NATO).</p> <p>A - LH black-out side lamp. B - LH direction indicator lamps. C - RH black-out side lamp. D - Earth E - Rear side and marker lamps and number plate illumination lamp. F - Black-out stop lamp. H - Not allocated. J - RH direction indicator lamps. K - Battery + power supply. L - Earth. M - Stop lamps. N - Not allocated</p>	

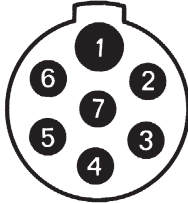
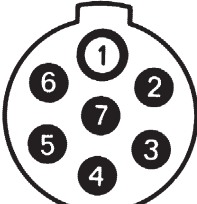
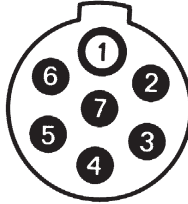
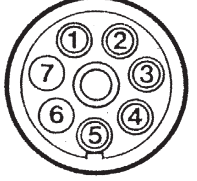
SUPPLY VOLTAGE	DESCRIPTION AND STANDARDS	SOCKET DIAGRAM (front view)
24 Volts	<p>24 N type socket (Standard: - BNA.R43.406 dated January 1976 - ISO 1185).</p> <p>1 - Earth. 2 - LH rear side and marker lamp and number plate illumination lamp. 3 - LH direction indicator lamps. 4 - Stop lamps. 5 - RH direction indicator lamps. 6 - rear side and marker lamps and number plate illumination lamp. 7 - Trailer braking lamp. Terminal 7 is scheduled in certain countries for supplying power to regulation trailer brakes. Under no circumstances must it be used as an earth terminal.</p>	 <p>600040</p>
24 Volts	<p>24 S type socket (Standard: - BNA.R43.409 dated April 1982 - ISO 3731).</p> <p>This is a supplementary socket which is assembled in addition to the 24 N socket.</p> <p>1 - Earth. 2 - Not allocated. 3 - Reversing lamp. 4 - Power supply. 5 - Earthing monitor. 6 - Supplementary power supply. 7 - Rear fog lamp.</p>	 <p>600041</p>
24 Volts	<p>24 P (oil tanker) type socket (Standard: - BNA.R.10.120 dated June 1977)</p> <p>This is the socket for ADR (Transport of Hazardous Substances) vehicles which is assembled in addition to the 24 N socket.</p> <p>1 - Earth. 2 - Valve lighting. 3 - Reversing lamp. 4 - Positive (+) power supply. 5 - Insulated earth. 6 - Not allocated. 7 - Rear fog lamp.</p>	 <p>600042</p>
24 Volts	<p>ABS specific type socket (Standard: - ISO 7638)</p> <p>1 - Power (30A). 2 - Control power supply (2A). 3 - Control earth (2A). 4 - Power earth (30A). 5 - Information (2A). 6 - Free. 7 - Free.</p>	 <p>600563</p>

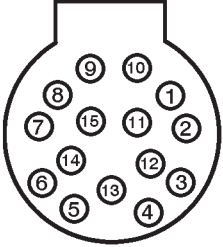
SUPPLY VOLTAGE	DESCRIPTION AND STANDARDS	SOCKET DIAGRAM (front view)
24 Volts	<p>15-pin trailer socket (Standard: - ADR 1999 IP54 and anti-unhooking - ISO 12098).</p> <p>1 - LH direction indicator lamps 2 - RH direction indicator lamps 3 - Rear fog lamp 4 - Earth 5 - RH rear side/parking and marker and registration plate lamps 6 - LH rear side/parking and marker and registration plate lamps 7 - Stop lamps 8 - Reversing lamps 9 - 24V positive (+) power supply</p> <p>Since July 1999, the 15-way socket replaces 24N and 24P sockets. Channels 10, 11, 12, 13, 14, 15 are unaffected.</p>	 <p>60 1990A</p>

The 15-way socket can be mounted on vehicles equipped with 24N and 24P sockets with the use of a 15-way 24N/24P adapter ref. N° 50 01 851 060 available from the RENAULT TRUCKS Spare Parts Department.

1.15.7 Additional direction indicator lamps

- On tractors and rigids

Should the lamps provided not meet all the requirements of the legislation in force, the bodybuilder may add extra lamps supplied with power by the same circuit as the front lamp or by a special circuit should one be available from the flasher unit. In all cases, comply with the power rating.

We strongly advise you to refrain from fitting any other lamp not required by the regulations.

- On trailers and semi-trailers

The standards in force concerning trailers require only two circuits for the flasher units: one circuit for the RH side and the other for the LH side. No additional lamps must be fitted on the trailer or semi-trailer which run from the monitored trailer lamps.

The addition of extra lamps entails the fitting of new wire runs which have to be drawn from the non-monitored lamp terminals in the flasher unit.

Overloading

Under no circumstances must extra lamps be fitted that exceed the power rating on the flasher unit. The main consequences of such overloading are as follows:

- The service life of the flasher unit is shortened, even when it would appear to be operating normally in spite of the overload.
- Operation is adversely affected by intermittent or permanent sticking of the contacts (the lamps remain lit without flashing)
- The appliance may be **off-circuit for the duration of the overload.**

Protection of the flasher unit (depending on the vehicle equipment)

In the event of excess current, the flasher unit will cease to operate. To return it to service:

- Move the flashing lights control switch to the 0 "off" position.
- Find the cause of the overcurrent (lines or lamps) and remedy it.

You will then be able to use the flashing lights again normally.

1.16 Air-operated equipment

Should it be necessary to add auxiliary equipment not provided by the manufacturer, it must compulsorily be connected to the circuit specifically provided for auxiliary equipment on the vehicle.

The compressed air consumption of such auxiliary equipment should under no circumstances compromise the filling times of the brake circuits laid down by the legislation in force.

The RENAULT TRUCKS Product Applications Department is at your disposal for any further information you may require.

1.16.1 Regulations

It is forbidden to modify officially approved braking circuits which conform with the standards set out by the Highway Code.

Any modification, without prior agreement from RENAULT TRUCKS, is done under the sole responsibility of the author of such a modification.

1.16.2 Polyamide pipes

Identification marking

Before removing any equipment or disconnecting polyamide pipes, mark the pipe in relation to the connection port on the equipment.

Coding system used on polyamide pipes (RENAULT TRUCKS standard):

Polyamide pipes are identified with a colour code marked with adhesive tape or by elastic rings.

Brakes code:

Main functions	Sub-functions		
	Constant pressure	Delivered pressure	Signalling pressure
Front service brake	Orange	Orange - White	Orange - Yellow
Rear service brake	Blue	Blue - White	Blue - Yellow
Parking brake	Green	Green - White	Green - Yellow
Trailer brake	Red	Red - White	Red - Yellow
Extra brake	Yellow	Yellow - White	Yellow - Yellow

Coding used on pneumatic appliances (DIN standard)

0 - Air intake	5 - Free		
1 - Pressurized supply	6 - Free		
2 - Delivered pressure	7 - Antifreeze		
3 - Air vent	8 - Lubrication.	81 - Inlet.	82 - Outlet
4 - Signalling pressure	9 - Water cooling.	91 - Inlet.	92 - Outlet

When the figure is followed by a second figure, the latter figure indicates the sequence number.

Example: 41, 42, 43: The figure 4 indicates the signalling function, the figures 1, 2, 3 indicate a sequence number in that function.

Replacement of a brake line

The entire length of a damaged polyamide pipe should be replaced by a pipe with identical characteristics (length and diameter), and corresponding with the standard in force. (See technical memo 8655 group 53000, part N° 50 20 034 156 available with spare parts). It must also be provided with coloured rings which are identical to those of the tube replaced.

Use an original manufacturer's pipe available from the RENAULT TRUCKS Spare Parts Warehouse.

The routing of a polyamide pipe must be carefully executed. Ensure there is no interference with sharp-edged metal parts and there is no routing close to high temperature units. The pipes must be held at regular intervals by plasticized clamps or run in existing ducting. Non-plasticized attachment clamps are absolutely forbidden. Take care to ensure the minimum radius of curvature of polyamide pipes is observed.

Dimension	4 x 6	6 x 8	9 x 12	12 x 16
Radius of curvature	30 mm	50 mm	70 mm	130 mm

Modification to the length of the chassis

Modification to brake pipe lengths requires braking response times to be checked out, in accordance with the legislation in force, and with agreement from the Type Approvals Department.

Connections for firtree type pneumatic brake pipes type "RILAX 2000"

For the fitting of this type of connector, refer to and comply absolutely with the technical instruction sheet NT 8852 (method and tooling) available from the RENAULT TRUCKS Spare Parts Department.

2. GENERAL RULES TO BE OBSERVED WHEN FITTING BODYWORK

Before carrying out any work, protect the cab with a cover.

Our vehicles are equipped with plates, pedestals or brackets. Preparation work may involve extra drilling or welding.

The principles described below must be adhered to.

2.1 General welding principles

2.1.1 Precautions

Protection of the batteries

A battery at the end of its charge produces a mixture of oxygen and hydrogen gas. The ignition of this gas presents dangers of battery explosion in the case of the presence of a source of heat nearby. As a result, during a welding operation near the batteries (i.e. engine compartment, front end of the vehicle), take out the batteries and store them in a well-aired location away from the place where welding is being done. This recommendation applies equally for grinding operations.

Soundproofing screens

In the case of welding or use of a sanding disk, either provide effective protection or remove the soundproofing screens, if necessary.

Protection of electrical and mechanical components

The vehicle is equipped with numerous electronic circuits: alternator, regulator, flasher units, speed limiter, ABS, etc.

Before any operation involving electric arc welding, make an earth connection by disconnecting the two negative (-) and positive (+) cables from the battery (starting with the earth cable) and connecting them to the frame earth. If the vehicle is equipped with a master switch, this should be kept engaged (circuit closed). Place the earthing clamp as near as possible to the point of welding, but never on rotating parts (prop shaft, fan hub, etc.) or on a subassembly having moving parts (i.e. air compressor, turbocharger, etc.).

Nearby plastic pipes and electrical cables, springs and air-suspension bags are to be protected or removed. This also applies when grinding or drilling.

When reconnecting the battery, observe the polarities, commencing with the positive (+) terminal. Reversal of polarity may cause irreparable damage to electronic components.

2.1.2 Preparation of parts for welding

Clean the parts, primarily at the location of the weld and at the connection of the earthing wire. This allows:

- free and regular electrical current flow (regularity of weld bead),
- avoidance of inclusion of impurities in the molten metal (weld quality),
- avoidance of spatter and emission of smoke (safety for the welder).

For conversions (extensions, reductions and reinforcement gussets), we recommend arc welding with electrode type B. When semi-automatic welding is used, the bodybuilder must be able to guarantee weld quality.

Preparation of specific edges on chassis frames

- A - With electric arc welding
- B - With weld under gas shield (MAG or MIG)
- J - 1 min., 2 max.

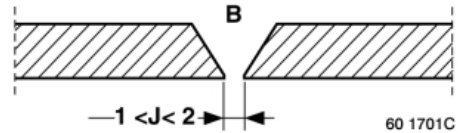
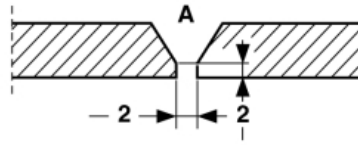

Method of welding to be specifically used on chassis frames

- Preparation of the edges at 45°
- Tack
- Position slave butts
- Weld on one single side
- Weld on second side
- Welds ground flush on both sides

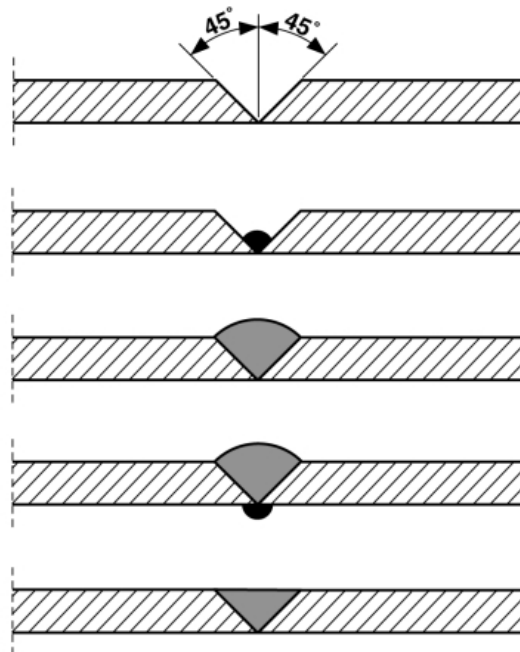

Slave butts

The object of slave butts is to avoid the starting of cracks at the outside edges of the weld joint. Before final welding align butts with plates of the same thickness as the plates to be joined, holding them in position using quick action clamping devices.

They must not under any circumstances be held in position by weld tacks on the plates to be joined.

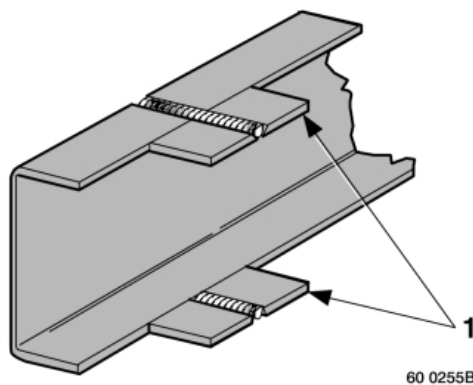

2.1.3 Welding process

Static or rotary arc welding set

- dc welding set recommended
- coated welding rods

Welding rod usage table

Electrode diameter (in mm)	2.5	3.15 (*)	4 (*)	5
Average current (in amperes)	75 to 90	95 to 110	120 to 140	150 to 175

(*) Most frequently used diameters

Coated welding rods recommended: standard NF EN 499 (January 1995)

EN 499 E 38 2 1 NI B for class: A - B - C

EN 499 E 46 2 1 NI B for class: D - E

EN 499 E 50 2 1 NI B for class: F

E 515/5 B 26 BH for steels class F

If steels are mixed, take the best performing steel electrode category.

Standard **NF EN 499** replaces standard NF A 81-309.

MIG or MAG semi-automatic welding set

MIG : - Metal Inert Gas

- for welding with electrode wire under inert gas shield (Argon, Helium...)

MAG : - Metal Active Gas

- for welding with electrode wire under active gas shield (CO₂ Argon + CO₂ Argon + CO₂ + O₂).
- used for welding mild steels.

Wire diameter (in mm)	Thickness to be welded (in mm)
0.8	up to 2 mm
1.0	from to 8 mm

2.1.4 Equivalent steel grades

The four classes relate to hot rolled steel plate with a high yield strength for cold forming, as currently set out in the French and European Standard NF EN 10149-2, which have replaced French Standard NF A 36.231. High yield strength sheet steel (dispersed carbon)

RENAULT TRUCKS Specification 31.09-402				
	Class C	Class D	Class E	Class F
UTS in N/mm ² min.	450	500	540	610
YP at 0.2% in N/mm ² min.	355	445	490	560
E % min.	23	20	18	15
KCV at - 20 °C J/cm ² min., longitudinal	35	35	35	37,5
Bending, transversal	1 e	1 e	1.5 e	1.5 e
Grain size	n° 5	–	–	–
= European equivalent French standards	S 355 MC NF EN 10149.2	S 420 MC NF EN 10149.2	S 500 MC NF EN 10149.2	S 550 MC NF EN 10149.2
= German standards equivalent DIN	QStE 380TM SEW 092	QStE 420TM SEW 092	QStE 500TM SEW 092	QStE 550TM SEW 092
= British standards equivalent BS	43 F 35 BS 1449	46 F 40 BS 1449		
= American standards equivalent ASTM	Gr. 50 050 YKL ASTM 607–50	Gr. 60 060 YKL ASTM 607–55	Gr. 70	Gr. 80
= EURONORM standards equivalent 149-80	FeE355 TM	FeE420 TM	FeE490 TM	E560 TM

2.2 Reinforcement, extension, reduction of sidemembers

2.2.1 Bans

It is absolutely forbidden to weld onto sidemembers, except for reinforcement, extension, reduction, and the following instructions must be observed:

- Do not weld on the edges of flanges.
- Do not weld in sidemember bending radii.
- In the case of flat irons: no directly opposing welds on the two faces of the same web - only "alternate" or "plug" welds are authorized.
- No welds which are less than 15 mm from the edge of a hole.

Insofar as possible, we advise you to have modifications of the lengths of sidemembers carried out by specialists.

- The general rules for welding in the paragraph entitled "General Principles of Welding" must be strictly followed. Only conversions (extensions or reductions) rendering the modified vehicle completely in conformity with a type approved chassis are permitted without additional testing, with certification from the vehicle manufacturer.

2.2.2 Reinforcement of sidemembers

- For inner reinforcements and chassis flange stiffeners, the thickness should be the same as the thickness of the sidemember.

NOTE

The steel grade must be identical to that used for the sidemember.

Examples of reinforcements

Sidemember upper and lower stiffeners

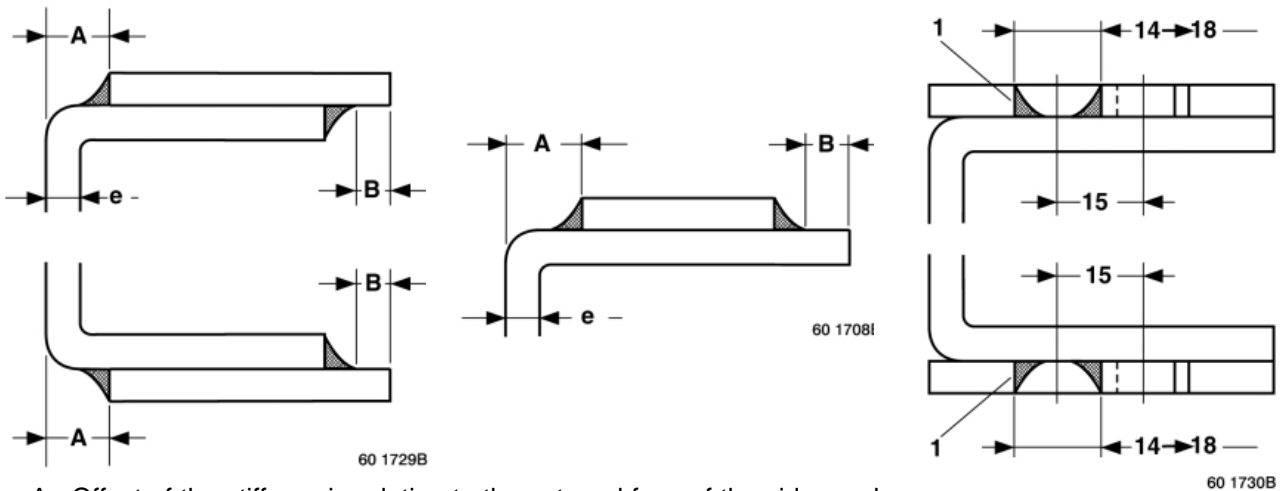

A : Offset of the stiffener in relation to the external face of the sidemember

B : Offset of the stiffener in relation to the edge of the sidemember

e : Thickness of the sidemember

1 : Welds through round or slotted holes, staggered

Thickness of the sidemember	A	B
$e < 6 \text{ mm}$	10 mm	15 mm
$e \geq 6 \text{ mm}$	15 mm	15 mm

Upper and lower stiffeners using angle-irons

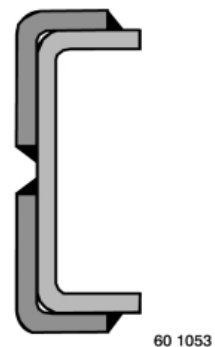

Methods of joining

In the case of stiffeners made from flats (on the upper flange or under the lower flange of sidemembers), we recommend attachment by:

Intermittent beads by electric welding: as guidance, 80 mm beads spaced 120 mm apart and staggered.

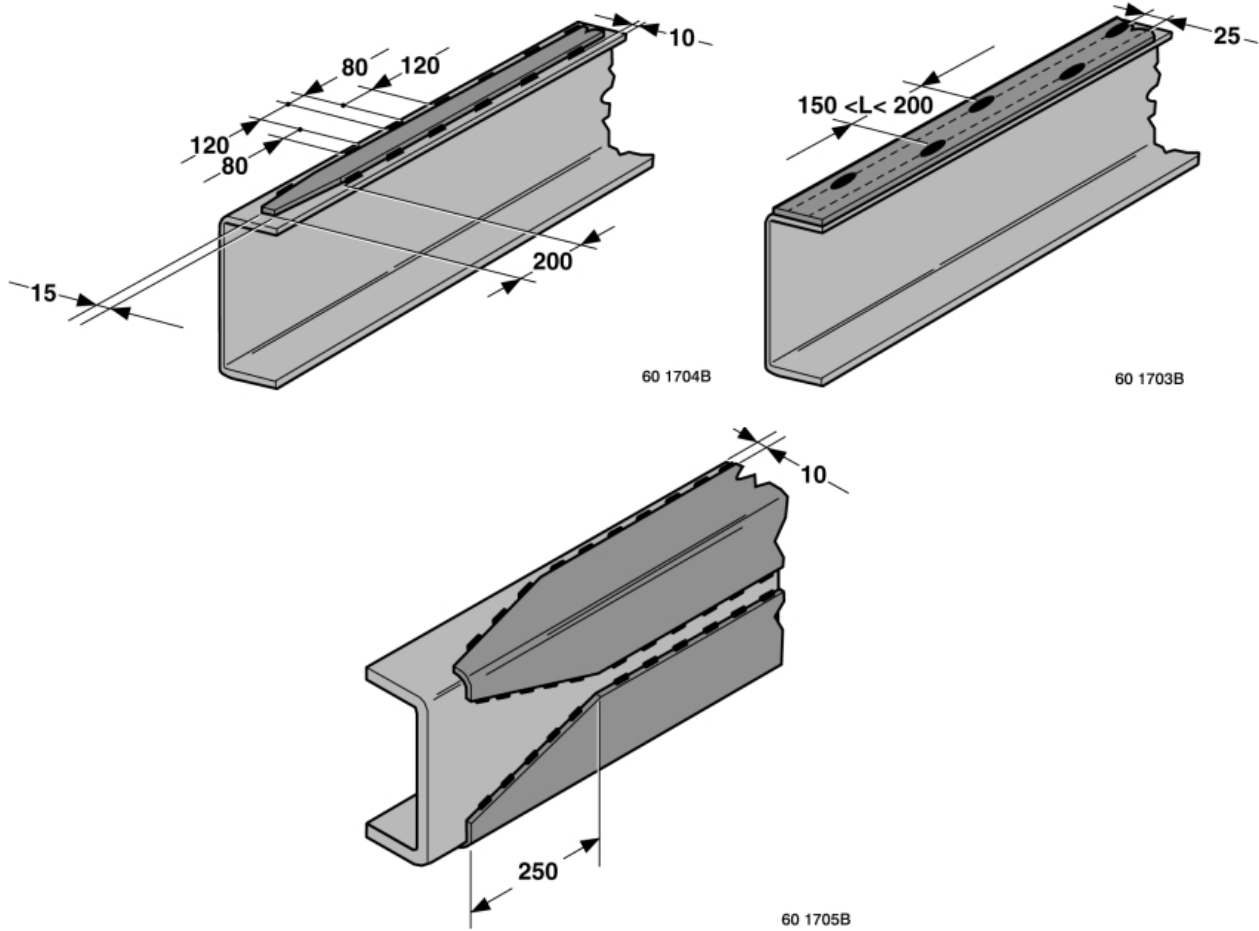

“PLUG” welds: as guidance, round holes dia. 14 to 18 mm or slotted (1) holes dia. 14 x 50 mm to 18 x 50 mm at a “pitch” of 200 mm min. to 300 mm. max., staggered, with good quality weld.

WARNING

No vertical welds on sidemember webs. No transversal welds on sidemember flanges.

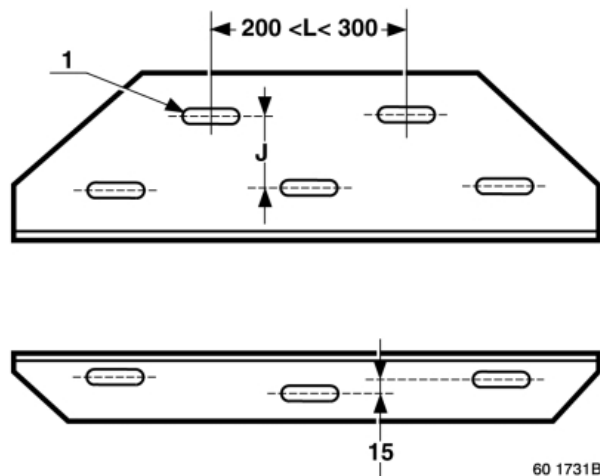

Extension, shortening of sidemembers in the wheelbase

Key

A – piece of sidemember added,

B – sidemember,

C – reconstituted stiffener,

D – welds projecting beyond flanged edge with butt-ends then longitudinal grinding (elimination of sharp edges),

e – thickness of the sidemember,

F – angle-iron of thickness (E) max. : $E \leq (e - 1 \text{ mm})$,

h – height of the sidemember,

J – weld penetration clearance (about 2 mm),

L – max. length of extension,

X – max. length of projection of the stiffener measured on the edge of the flange (extension),

Y – min. length of support of the stiffener measured on the edge of the flange of the sidemember (extension).

Z – min. length of support of the stiffener measured on the edge of the flange (stiffener without extension).

Extension of the sidemembers in the wheelbase

Sidemember without stiffener flat on the flange

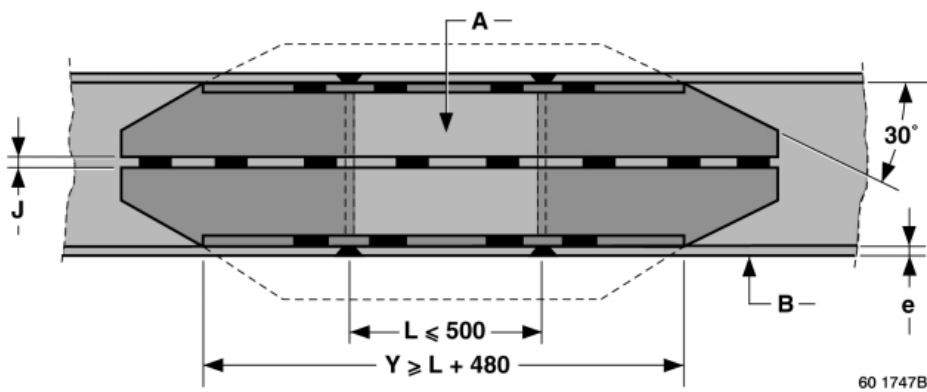

Sidemember with stiffener flat on the flange

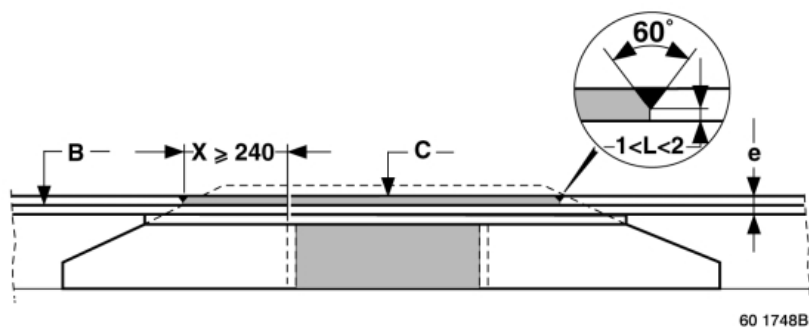

Sidemember with stiffener flat on the flange

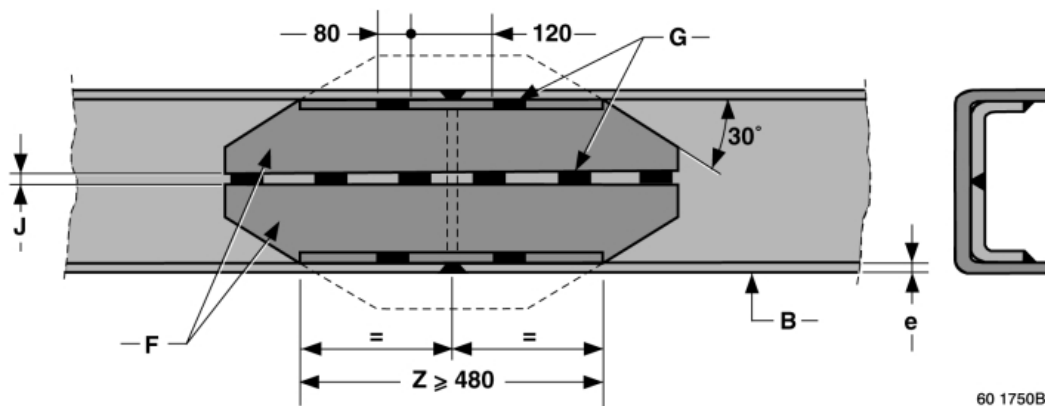
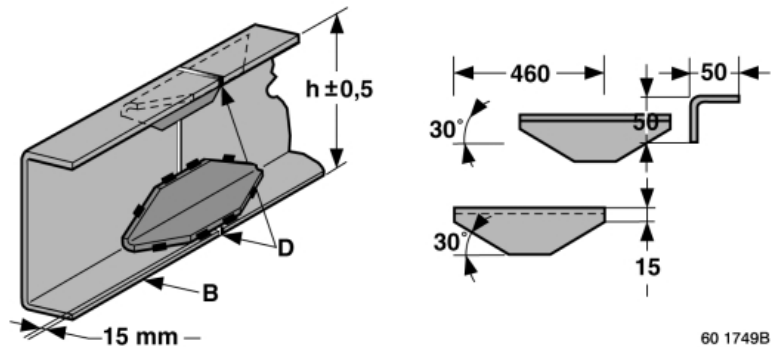

2.2.3 Modification of the rear overhang

If the bodywork or the equipment fitted do not alter the weight and dimensional characteristics of the chassis entered on the description sheet, the vehicle can be submitted to the Type Approval Department without any action being necessary on the part of RENAULT TRUCKS (within the permitted limits in force).

- Welding stiffeners are required for drawbar rigids or if the extension is longer than 400 mm for a solo vehicle. Examples : Drawbar rigid; tail lift; crane at the rear of the chassis; tipper; etc.
- Extension of the rear overhang will also be required when the rear extremities of the bodywork project beyond the maximum authorized value which is indicated on the bodybuilder's drawing and calculation sheets relating to the vehicle.

Attachment of cross-members

Cross-members should be attached with nut and bolt hardware of the 10.9 SSS protected class as per standard 01714002 and distributed by RENAULT TRUCKS.

Towing cross-members

Please refer to the chapter on "Drawbar cross-members" in the section entitled "RENAULT MAGNUM E-TECH special bodybuilding features".

Intermediate cross-members

In the case of extension of the wheelbase or the rear overhang, it is essential to add cross-members, so as not to weaken the rigidity of the frame.

Observe the following instructions:

- Between two cross-members, the spacing must be no greater than the original spacing.
- If the extension to the overhang is longer than 500 mm, the rear cross-member must be moved and an intermediate cross-member fitted which is identical to the others.

2.3 Attachment of bodywork

The bodywork must be correctly attached so that both the static and dynamic stresses are freely transmitted without causing excessive local strain, which could prejudice the reliability of the chassis frame or affect the road behaviour of the vehicle.

The following rules apply to the fastening of various standard bodies fitted to our chassis cabs, such as platforms, vans, tippers, and tankers. For special cases, contact the RENAULT TRUCKS Applications Department. For body design (i.e. length, load distribution, location of accessories on sidemembers, etc.) refer to the CD-ROM "Information for Bodybuilders" or the 1:20 scale bodywork drawing which we supply upon simple request.

Fastenings should always be tightened progressively and alternately.

The shape of sub-frames or underbodies should always be tapered towards the front (i.e. at the back of the cab), so as to avoid sudden variations in inertia (refer to chapter entitled "Finishing of sub-frame behind the cab").

2.3.1 Bans

- The use, drilling or welding of spring hangers.
- Any modification of: the chassis, the driveline, or the suspension.
- Fastening of sub-frames to our sidemembers by welding.
- The drilling of stiffener gussets.
- The notching of sidemembers, gussets or cross-members.
- With the exception of special cases described in this document, the use or modification of our nut and bolt hardware and our riveting for the attachment of a body or sub-frame.
- The attachment of sub-frames by U-bolts.

All bodies attached by clamps and brackets must mandatorily have 1 inertia stop to the rear of each side-member to stop the body from moving in the event of fierce braking, as well as 4 body guides 2 at the front, 2 at the rear).

For bolted fastenings, comply with the following instructions:

- By preference use brackets attached to the chassis.
- Use the fixing bolt holes dia. 11, 13 or 15 mm depending on the particular vehicle, spread out along the length of the sidemembers of the chassis frame.
- Take good note of the attachment principles, set out in the chapter on the "Attachment of sub-frames".

2.3.2 Protection against exhaust heat radiation

Depending on the features of your bodywork or equipment, the fitting of a heat shield on the original protection is recommended.

2.4 Sub-frame

In order to attach bodywork to the frame of the chassis, you should allow for the fitting of a sub-frame whose module of inertia (I/V) is determined in accordance with the vehicle series in question (refer to the section entitled "RENAULT MAGNUM E-TECH special bodybuilding features").

In order to ensure better distribution of the stresses along the sidemembers, you must allow for a cut-out as far forward as possible under the cab.

2.4.1 Finishing of sub-frames behind the cab

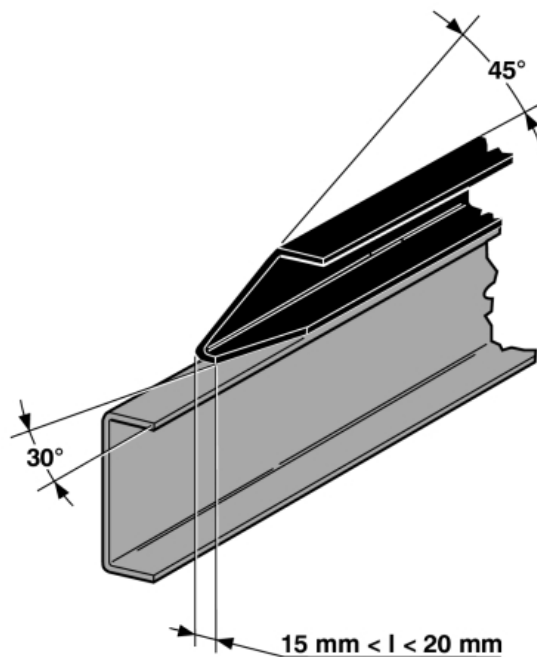

60 2538A

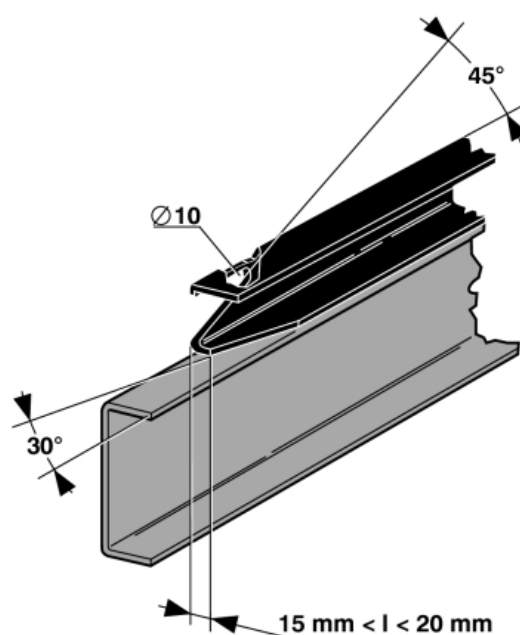

60 2539A

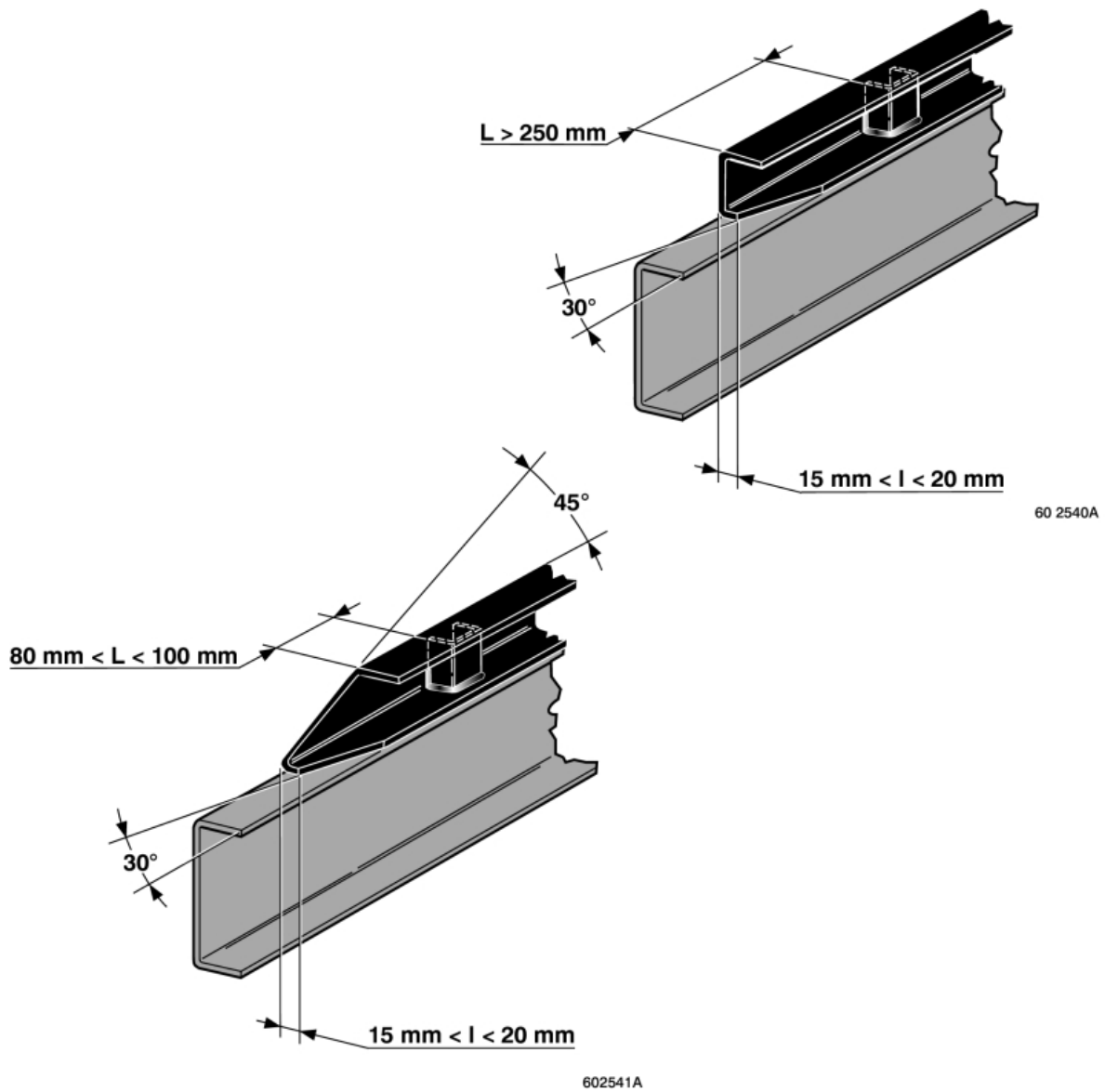

When the sub-frame is constructed of square or rectangular tube section, we also suggest the cut-out shown below.

A: Blank off with 1.5 mm thick sheet metal

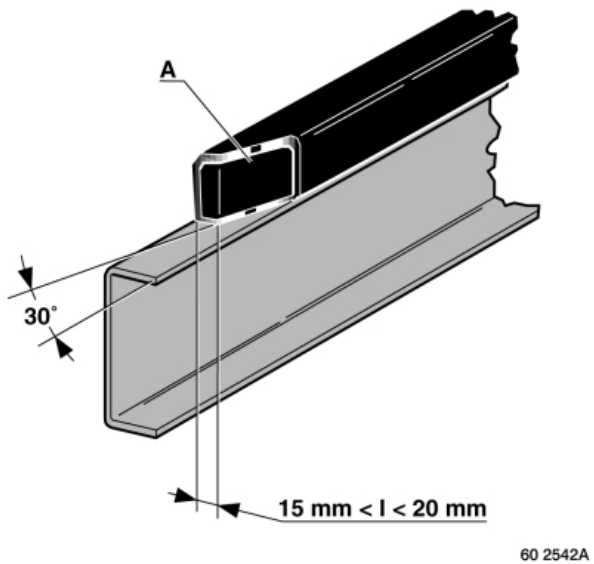

2.5 Nuts and bolts, tightening torques for parts in steel and cast iron

The torques indicated in the table are the nominal torques (i.e. average value calculated on the basis of the minimum and maximum torque).

Class III is the class covering precision tightening ($\pm 20\%$ of nominal torque) in accordance with Standard 01504002 (coefficient of friction 0.15 ± 003).

The tightening torques are given for nut and bolt hardware that is dry and coated with Dacromet.

Description	Characteristics	Class of Steel	Part N°	Tightening torque
Screw	H 10 x 125 L 30	10.9	50 03 101 460	60 N.m
	H 10 x 125 L 50	10.9	50 03 101 148	60 N.m
	H 12 x 125 L 40	10.9	50 03 101 151	110 N.m
	H 12 x 125 L 45	10.9	50 03 101 749	110 N.m
	H 12 x 125 L 50	10.9	77 03 101 679	110 N.m
	H 12 x 125 L 60	10.9	50 03 101 153	110 N.m
	H 14 x 150 x 40	10.9	50 03 101 161	170 N.m
	H 14 x 150 x 50	10.9	50 03 101 162	170 N.m
	H 14 x 150 x 60	10.9	50 03 101 163	170 N.m
	H 14 x 150 x 90	10.9	50 03 101 169	170 N.m
	H 14 x 150 x 100	10.9	50 03 101 660	170 N.m
	H 14 x 150 x 110	10.9	50 03 101 171	170 N.m
	H14 x 150 x 120	10.9	50 03 101 172	170 N.m
	H14 x 150 x 130	10.9	50 03 101 887	170 N.m
	H14 x 150 x 140	10.9	50 03 101 173	170 N.m
	H 16 x 150 x 50	10.9	50 03 101 103	220 N.m
Collar screw	H 10 x 125 L 30	10.9	50 03 002 048	60 N.m
	H 12 x 125 L 40	10.9	50 03 002 049	110 N.m

Description	Characteristics	Part N°
Cone washer	10 x 20 x 2.2	50 03 058 081
	10 x 24 x 2.8	50 03 058 071
	10 x 27 x 2.8	50 03 058 076
	12 x 30 x 3.2	50 03 058 075
	14 x 28 x 3	50 03 058 069
	16 x 32 x 3.4	50 03 058 034
	16 x 39 x 3.6	50 03 058 070
Flat washer	10 x 22 x 3	50 03 053 453
	10 x 27 x 3	50 03 053 455
	10 x 24 x 2.5	50 03 053 026
	12 x 28 x 5	50 10 054 526
	12 x 32 x 2.5	50 03 053 441
14 x 30 x 5	50 03 053 511	
Cone washer "Belleville" type	14.5 x 35 x 1.8	50 10 377 934

Description	Characteristics	Class of Steel	Part N°	Tightening torque
Nut	10 x 125	10	50 03 032 156	60 N.m
	12 x 125	10	50 03 032 157	110 N.m
	14 x 150	10	50 03 032 159	170 N.m
	16 x 150	10	50 03 032 236	220 N.m
Locknut DRH (flanged)	10 x 125	10	50 03 034 246	60 N.m
	12 x 125	10	50 03 034 248	110 N.m
	14 x 150	10	50 03 034 250	170 N.m

2.6 Addition of equipment to the bodywork

The attachment of equipment to the bodywork must be done with fluidtight crimping nuts.

Tooling and crimping nuts

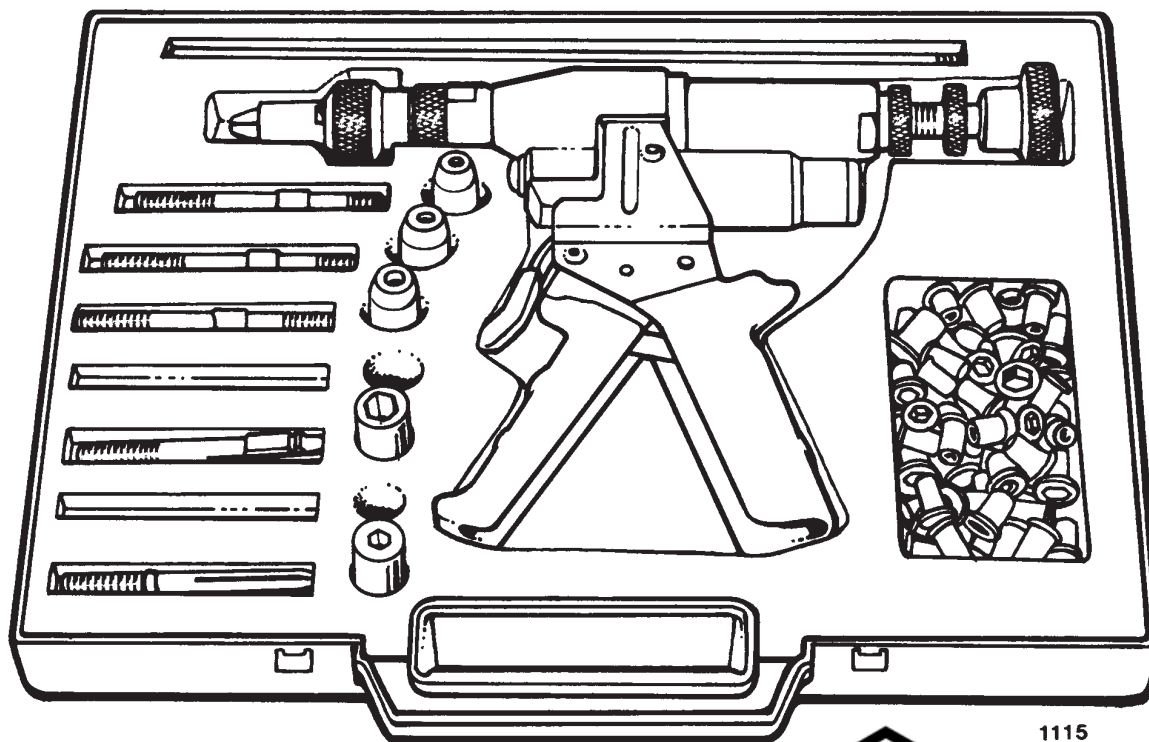

M6 crimp nut - hexagonal barrel

Part N°: 50 03 043 050



1115

Method:

- Drill a dia. 9.2 mm hole (refer to chapter entitled "Drilling of bodywork members for the fitting of accessories").
- Use the OPEX tooling from OTALU S.A. (RENAULT TRUCKS approval N° 8162).
- Punch out the hexagonal.
- Insert the nut for crimping.

Information:

- Tightening torque max. 10 Nm.
- Length of barrel projecting under bracket after crimping: 17 mm.

M8 crimp nut - hexagonal barrel

Part N°: 50 03 043 052

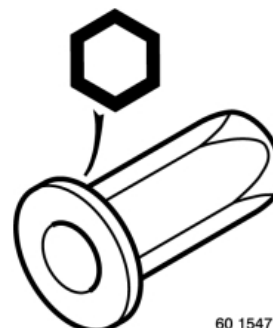

60 1547

Method:

- Drill a dia. 11.2 mm hole (refer to chapter entitled "Drilling of bodywork members for the fitting of accessories").
- Use the OPEX tooling from OTALU S.A.
- Punch out the hexagonal.
- Insert the nut for crimping.

Information:

- Tightening torque max. 24 Nm.
- Length of barrel projecting under bracket after crimping: 21 mm.

2.7 Rear run-under guard

RENAULT TRUCKS obtains approval for its equipment to cover the requirements of its range. Their attachment being by means of bolts, this allows them to be moved down along the sidemembers to suit such modifications that the chassis may undergo. This must be observed, along with the maintenance of the attachment method detailed on the 1:20 scale bodywork drawing and compliance with the dimensional requirements under the regulations.

A vehicle which is not equipped at the time of delivery can be fitted afterwards, following a conversion making the fitting compulsory, using items which can be supplied from the Parts Stores of our dealers.

Changing of position of items of equipment

Modifications of a RENAULT TRUCKS vehicle for the fitting of bodywork and equipment requires technical approval to be obtained from the Product Applications Department of RENAULT TRUCKS.

3. SPECIFIC EQUIPMENT FEATURES

3.1 Running the engine when vehicle stationary

Under the conditions of running an engine for a long period under load, it is vital to fit an additional cooler unit in order to keep the temperature of the engine at a normal level (water temperature approx. 80° C).

The prolonged use of the engine under these conditions can cause malfunctions which could adversely affect the life of the engine.

3.2 Mounting of power take-offs and flanged pumps

RENAULT TRUCKS power take-offs (PTOs) and their adapter kits should be ordered from the RENAULT TRUCKS Spare Parts Department. In order to carry out the fitting, refer to the specific information circulars that are available from the Product Applications Department.

Bearing in mind the weight and the large overhang required for certain PTOs having flanged pumps, the rear of these units should be supported by a suitable bracket attached to the rear of the gearbox.

Comply with the standard NF ISO 7653

IMPORTANT

It is compulsory at the time of fitting a power take-off to ensure that there is a certain amount of play in the setting adjustment, so as to allow an ideal backlash of 0.15 to 0.25 mm then to fit a gasket or apply paste in order to achieve a good seal and also to top-up the oil level. (Refer to the vehicle maintenance handbook). Refer to our Product Information Sheet and 1:20 scale bodywork drawing on "power take-offs", which can be requested from our Product Applications Department.

3.3 Front power take-offs (crankshaft nose)

RENAULT TRUCKS pre-arrangement

For belt drive units, pulleys with extra grooves fitted to the engine may be available.

Consult the Product Applications Department to obtain the relevant information and technical approval for the assembly.

3.4 Front and rear power take-offs

3.4.1 Propeller shaft alignment

In order to achieve satisfactory propeller shaft alignment, several minimum basic **criteria** have to be observed.

Angularity criteria (or: equivalent angle of inclination β_E permissible for all articulations).

This angle β_E must comply with the following condition:

$$\beta_E = \sqrt{|\beta_a^2 \pm \beta_b^2 \pm \beta_c^2 \pm \dots|}$$

$$\beta_E \leq 3^\circ$$

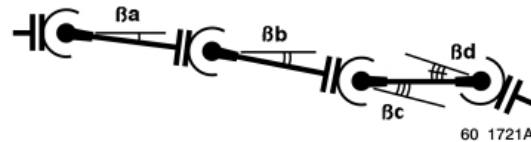

Rule for sign β :

Yoke N° 1 is to be considered as the reference yoke.

$\beta > 0$ when the leading yokes are parallel to the first leading yoke (M_a).

Example 1:

$$\beta_E = \sqrt{|\beta_a^2 + \beta_b^2 + \beta_c^2 - \beta_d^2|}$$

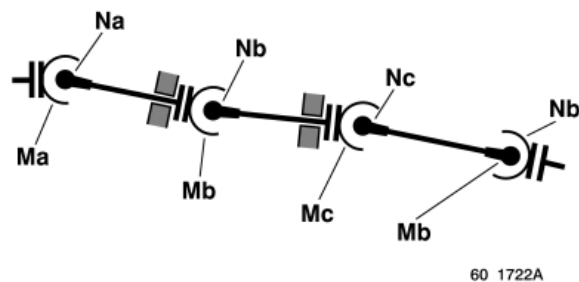

M - Leading yokes

N - Trailing yokes

$\beta < 0$ when the leading yokes are perpendicular to the first leading yoke (M_a).

Example 2:

$$\beta_E = \sqrt{|\beta_a^2 + \beta_b^2 - \beta_c^2 + \beta_d^2|}$$

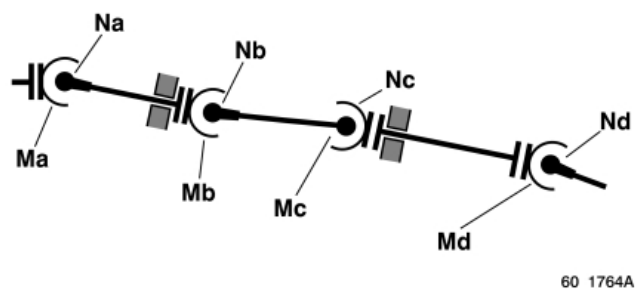

Angular acceleration criteria θ_1

Calculated criterion for a theoretical maximum speed of rotation (N).

$$\theta_1 = \left(\beta_E \times \frac{\pi}{180} \right)^2 \times \left(\frac{\pi \times N}{30} \right)^2$$
$$\theta_1 \leq 270$$

θ_1 : criterion of acceleration in rd/s²
N : max. speed of rotation in rpm

NOTE

This value is calculated without dynamic amplification of the prop shaft tubes and bearings.

Measured criteria θ_2 :

The angular acceleration or torsional vibrations criteria value θ_2 must not exceed 1500 rd/s² at the PTO output or at any point whatsoever of the driveline for a downstream inertia of I such that $I \leq 0.2$ kg/m².

$$\theta_2 \leq 1500 \frac{\text{rd}}{\text{s}^2}$$

NOTE

This limit value θ_2 takes into account possible dynamic amplification of the driveline.

Transversal stress criteria for prop shaft tubes and bearings.

Example β_1 and β_2 maximum not to be exceeded.

- $\beta_a < 2^\circ$ for a prop shaft with bearing.
- $\beta_b < 7^\circ$ for a prop shaft with sliding yoke.

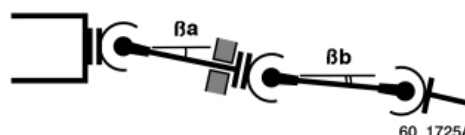

NOTE

If this 7° value has to be exceeded for space or clearance reasons, the vehicle manufacturer must be consulted.

3.4.2 Propeller shaft balancing

Permissible imbalance value (B):

$$B \leq 3 \frac{g \times cm}{kg} \text{ per balancing plane}$$

- 1 - 1/2 prop shaft
- 2 - prop shaft

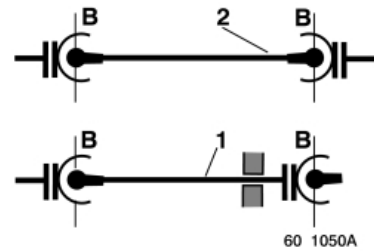

NOTE

$$g = m = 10 \text{ m/s}^2$$

3.4.3 Maximum permissible length of a prop shaft as a function of the rotating speed (L, L1 or L2)

- L : Distance between centres of articulation of a prop shaft.
- L2 : Distance between centres of articulation welds of a half prop shaft.
- L1 : Distance between centres of articulations of a half prop shaft.
- L1 = L2

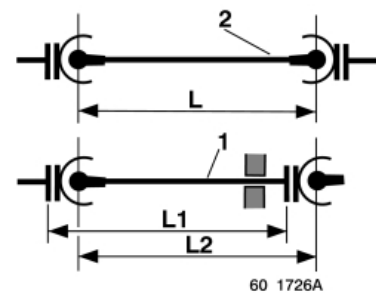

$$L = \sqrt{\frac{K}{Nt \times 1,2}} \quad \text{with} \quad K = 0,75 \times 1,22 \times 10^5 \times \sqrt{D^2 + d^2}$$

- Nt = prop shaft maximum operating speed
- 1.2 = safety coefficient
- D = prop shaft large diameter
- d = prop shaft small diameter

3.5 Vehicle driveline (powertrain)

Any modification to the driveline is forbidden. For special cases, agreement must be obtained from the RENAULT TRUCKS Product Applications Department.

Any propeller shaft modifications must only be carried out in conformity with the requirements of paragraphs 3.4.2 and 3.4.3.

3.6 Mounting of handling cranes

The installer of the crane is responsible with regard to compliance with the regulations, and also for the stability of the vehicle. The recommendations of RENAULT TRUCKS are only concerned with the attachment of the equipment.

3.6.1 Mounting on the sub-frame

The mounting of a crane on the chassis behind the cab or in the rear overhang requires the fitting of a specific sub-frame.

The sub-frame module is defined in the graph of inertia in accordance with the lifting torque only for a crane mounted behind the cab and on rigid or drawbar rigid vehicles (refer to the next page).

For all mountings of cranes in the rear overhang, off-limits and on tractors, consult the RENAULT TRUCKS Product Applications Department.

The sub-frame must be in one single piece, starting from the rear of the cab, and extending as far back as the rear tip of the overhang. The front end must be finished in a single or double bevel (refer to the chapter 2.4.1 entitled "Finishing of the sub-frame behind the cab").

Should the crane be mounted in conjunction with another item of mobile equipment, one single sub-frame shall be designed in accordance with the item of equipment that places the most strain on the sidemembers.

3.6.2 Graph of the moment of inertia of the sub-frame as a function of the lifting torque

Example:

A chassis with sidemembers 252 mm long, fitted with a crane having a lifting capacity of 10 tonnes per metre. The chassis requires a sub-frame built of size 160 U-section beams (— direction of reading). The U-section can be replaced by any other steel section offering equivalent total inertia.

Height of sidemember

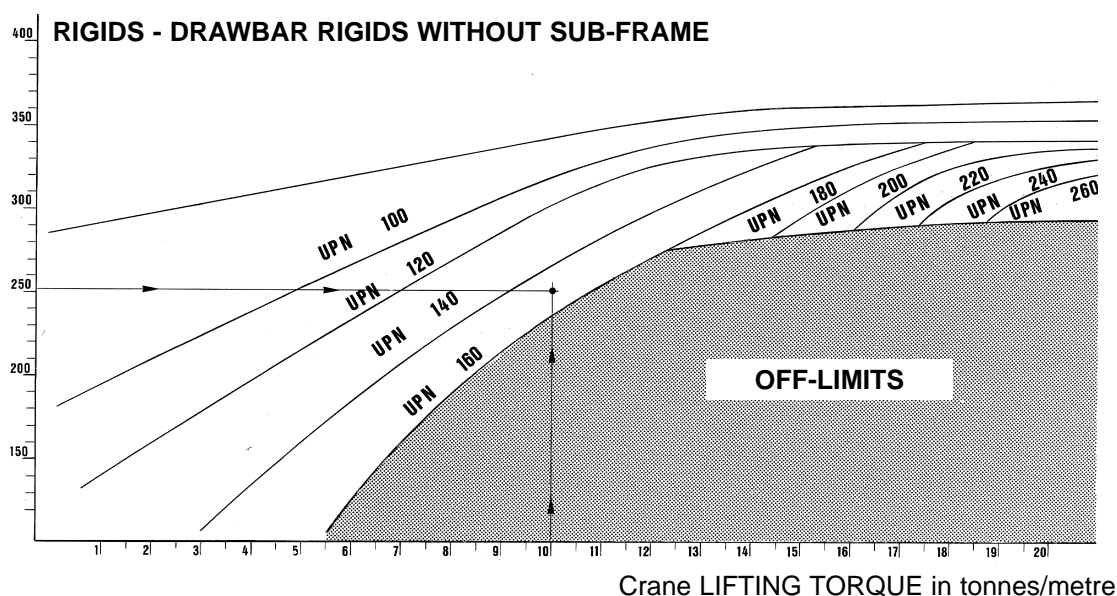

The U-section beams (UPN) can be replaced by any other steel section offering equivalent total inertia (I/V).

UPN 100 : I/V = 41200 mm ³	UPN 160 : I/V = 116000 mm ³	UPN 220 : I/V = 245000 mm ³
UPN 120 : I/V = 60700 mm ³	UPN 180 : I/V = 150000 mm ³	UPN 240 : I/V = 300000 mm ³
UPN 140 : I/V = 86400 mm ³	UPN 200 : I/V = 191000 mm ³	UPN 260 : I/V = 371000 mm ³

WARNING

Before undertaking the mounting of a crane on a vehicle, it is essential to make calculations to check the load distribution, and to determine the new maximum body length of the vehicle, whilst complying with:

- The plated gross vehicle weight (GVW).
- The maximum plated axle loads.
- The maximum rear overhang indicated in the Type Approval Department's descriptive sheet and the body-work diagram.

Should such limits be exceeded and in all cases where the work does not comply with the type approval department descriptive sheet, special authorization must be requested from the RENAULT TRUCKS Product Applications Department.

In addition to this, the bodybuilder will be responsible for commissioning the equipment.

3.6.3 Crane in the rear overhang

The installer of the crane is responsible with regard to compliance with the regulations, and also for the stability of the vehicle. The recommendations of RENAULT TRUCKS are only concerned with the attachment of the equipment.

The sub-frame required for such assemblies must be diagonally braced in accordance with the diagram below, using U-section beams with a module that is immediately lower than that recommended for the sub-frames.

Example: A sub-frame made of size 140 U-section beams shall be diagonally braced with size 120 U-section beams.

For a crane mounted in the rear overhang, in addition to the recommendations contained in the "WARNING" paragraph above, the following must also be observed:

- The minimum front axle load, for a vehicle fitted with a body and equipped with crane.
- The maximum plated front axle load shedding: 5% of the value of the weight of the chassis cab on the front axle.

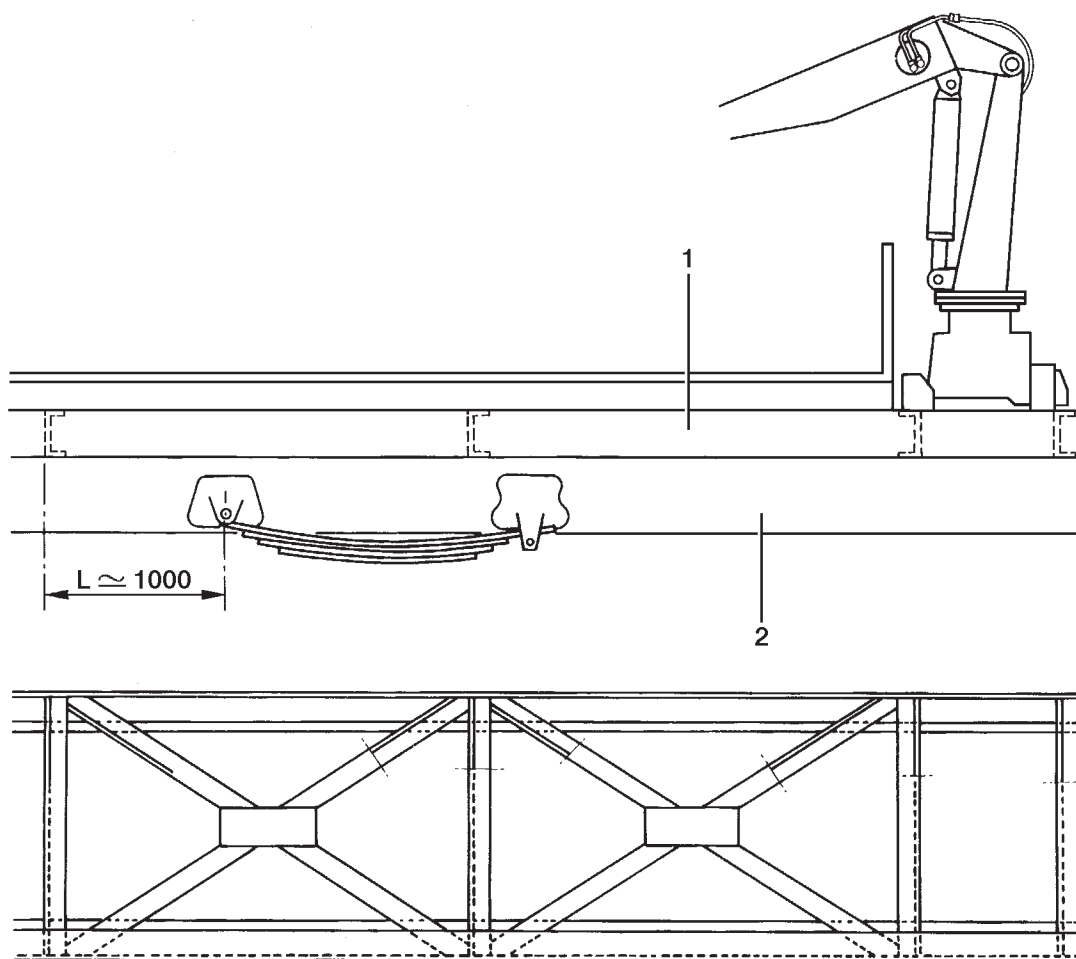

60 1720A

- 1 - Sub-frame
- 2 - Vehicle chassis

3.7 Tail lifts

3.7.1 Sub-frames

In the majority of cases, the mounting of a tail lift involves the fitting of a sub-frame to the vehicle. Such a sub-frame must reinforce the entire length of the chassis, with the bevelled front end being located as far forward as possible under the cab.

The module to be used for the sub-frame must be determined for tail lifts:

- without landing legs, for a capacity of 400 to 2,000 kg
- with landing legs, for a capacity of 1,000 to 2,000 kg
- by referring to the graph of inertia of the sub-frame depending on the load to be lifted, plus the information contained in the paragraph entitled "Special Recommendations", which also deals with tail lifts with a capacity of 1,500 kg without landing legs and tail lifts with a capacity of 2,000 kg with or without landing legs.

3.7.2 Attachment

The tail lift is to be fastened in position with bolted plates. In all cases, the design of the attachment should involve that of the body sub-frame as well. Nut and bolt hardware is to be of class 10.9 fine pitch with a diameter of 12 mm. The plates are to be fastened in position with at least 6 nuts and bolts on each side of the chassis and by 3 bolts and nuts or only by welding to the sub-frame.

If necessary, it may be necessary to wedge the tail lift beam or plate on the lower flange chassis sidemember, so as to avoid flexing of the sidemember.

NOTE

Do not weld the bolted plate to the chassis.

WARNING

In all cases of conversions for tail lifts, it is absolutely essential to calculate the new length of body, to ensure compliance with:

- The maximum plated gross vehicle weight (GVW).
- The maximum load on the front axle, with the vehicle fitted with its body and equipped with tail lift.
- The maximum plated loads on the front and rear axles.
- The maximum rear overhang indicated in the Type Approval Department's descriptive sheet and the body-work diagram.

If any loads are exceeded, you should consult the RENAULT TRUCKS Product Applications Department.

3.7.3 Electrical connections for a tail lift

Electrical connections should comply with the recommendations set out in the chapters entitled "Fitting of specific equipment" and "Electrical equipment".

3.7.4 Special recommendations for tail lifts from 1500 to 2000 kg without landing legs

1,500 kg tail lift

- This is only possible using our chassis with a GVW equal to or greater than 16 tonnes.

2,000 kg tail lift

- This is only possible using our chassis with a GVW equal to or greater than 19 tonnes.
- For off-limits and for vehicles with a lower capability, consult the RENAULT TRUCKS Product Applications Department.

Should the run-under guard have to be modified, care should be taken to ensure compliance with regulations in force.

3.7.5 Graph of the moment of inertia of the sub-frame as a function of the lifting torque

How to use the graph

- Draw a straight line joining the type of tail lift in question (lower part of the graph) to the mark corresponding with the height of the sidemember in mm.
- Draw a straight line from the value of the sidemember height.
- Read the value for the sub-frame at the intersection of these two lines.

NOTE

For the mounting of tail lifts on 6x2 vehicles, it is essential to consult the RENAULT TRUCKS Product Applications Department.

Example:

Take a chassis with 234 mm high sidemembers, equipped with a 750 kg tail lift.

It requires a sub-frame made of size 80 U-section beams.

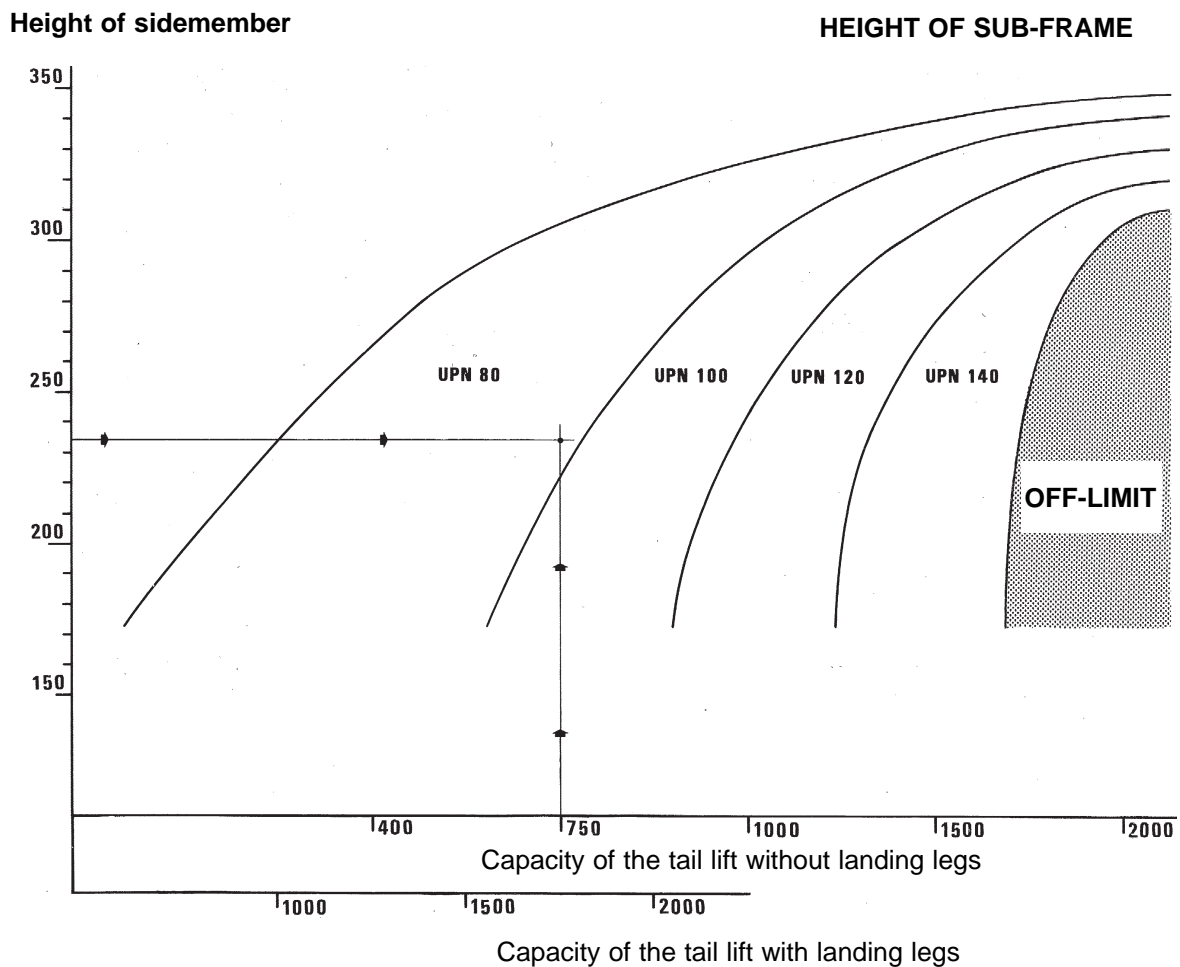

NOTE

The size 80 U-section beams can be replaced by any other section which gives an equivalent inertia (I/V).

PN 80: $I/V = 26500 \text{ mm}^3$

UPN 120: $I/V = 60700 \text{ mm}^3$

PN 100: $I/V = 41200 \text{ mm}^3$

UPN 140: $I/V = 86400 \text{ mm}^3$

3.8 Sub-frame box sections

The recommended box sections should:

- be constructed in sheet metal which is as thick or thicker than that used for the sub-frame.
- stretch over the entire rear of the sub-frame, starting gradually at least one metre in front of the foremost spring hanger of the rear spring.

WARNING

If the sub-frame is to be constructed in a material other than commercially available U-section beams, we approve all other sections on condition that the modulus of inertia of the "truck sidemember + sub-frame" section, measured at the centre-line of the rear axle, be at least equal to the modulus which we recommend (refer to the previous page).

It is forbidden to make any butt welds on the sub-frame in the area defined as follows:

- from the centre-line of the rear axle up to 500 mm to the rear of the rearmost spring hanger of the rear spring, in the case of 4x2 and 4x4 vehicles.
- from the centre-line of the middle axle up to 500 mm to the rear of the centre-line of the rear axle, in the case of all other vehicles.

3.9 Fitting of specific equipment (for example: refrigerator unit, tail lift)

3.9.1 Electrical connections

Refer to the recommendations for use (chapter on "Electrical equipment" in the General Section).

The power supply cable should be in one single piece, with a cross-section calculated for a max. rating of 5 Amps per mm². The power supply must be protected by a fuse and controlled by a specific master switch during fitting. It is compulsory for the cables to be connected to the battery terminals. The fuse and the master switch must be located as close to the battery connection as possible (in order to keep to a minimum the length of unprotected line).

The electric power and auxiliary wiring must compulsorily be independent from that of the vehicle network.

For this, you should contact the RENAULT TRUCKS Product Applications Department in order to obtain its permission.

In the case of conversion of an independent self-contained unit on the front end of the body, an access ladder and platform for maintenance purposes should be provided.

3.9.2 Installation of receivers or generators with a voltage of more than 24 V

Comply with the standards in force and with the safety regulations covering installations and safety of the person (decree dated 14/11/1988). The protective earth is to be made on the equipment, and never on the vehicle structure.

3.10 Tapping on the diesel fuel tank

It is forbidden to drill the tank for the installation of a tapping point.

3.11 Fifth wheels (baseplates and couplings)

Tractor chassis are normally supplied as original equipment with bolted angle irons. In this case they allow for the longitudinal positioning of the baseplate for the fifth wheel on the chassis, in order to ensure good load distribution on the tractor axles.

The fifth wheel is located on these angle-irons by the use of a cross-member and/or a baseplate (in certain cases the baseplate is sufficient).

The fitting of the fifth wheel must allow for the manoeuvring of a swan-necked semi-trailer in accordance with the ISO Standard in force : ISO 015/1726: Road vehicles – mechanical links between tractors and semi-trailers - interchangeability.

The bedplate and the baseplate must be independently mounted, with a minimum strength equal to that of the attachment for the fifth wheel.

Baseplates for each type of vehicle are available in several heights from the Spare Parts Department.

Refer to the Product Applications Department.

3.11.1 Mounting standards

Comply with the standard in force.

Kingpin 50 mm (2") dia.

The attachment of the fifth wheel to the chassis must be done using 12 nuts and bolts size M16, quality class 10.9.

Kingpin 90 mm (3.5") dia.

For details of the attachment of the fifth wheel, refer to the Product Applications Department or comply with the recommendations of the supplier.

These values apply equally for the attachment of the baseplate.

As far as swan-necked semi-trailers are concerned, which are not constructed in accordance with the ISO Standard in force, the attachment of the fifth wheel must take into account the instructions given above, whilst conforming with the capability of the tractor to manoeuvre, i.e. it must not come into contact with parts of the chassis, such as mudguards, rear lamps, registration plates, the back end of the chassis, the tyres, etc.

If the changing of position of the fifth wheel towards the front causes any interference of the mounts of the baseplate with those of a cross-member, you are obliged to refer to the RENAULT TRUCKS Product Applications Department.

Drawing for drilling the baseplate for the attachment of the fifth wheel using 12 nuts and bolts dia. 16 mm (DIN Standard 74081)

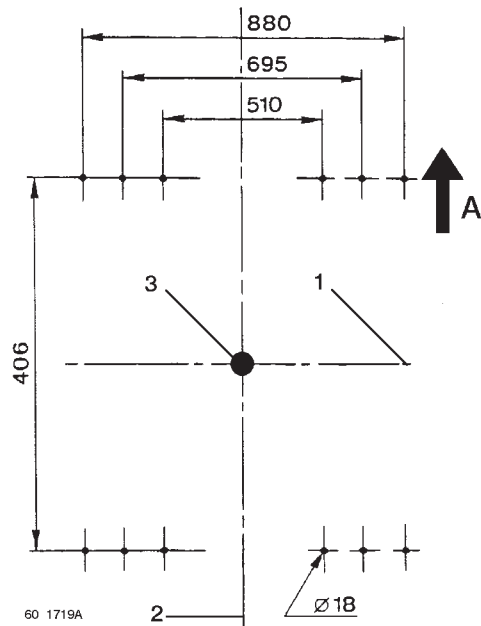

Drawing for drilling the baseplate for the attachment of the fifth wheel by 12 nuts and bolts; dia. 16 mm with slotted holes (Standard NF R 41-171 dated October 1986)

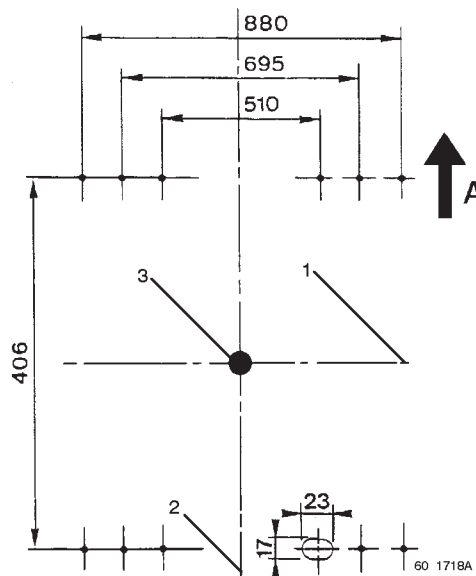

- A - Direction of movement of vehicle
- 1 - Lateral axis
- 2 - Longitudinal axis of the tractor engine
- 3 - Kingpin axis

**CHAPTER -B-
“RENAULT MAGNUM E-TECH”
SPECIAL BODYBUILDING FEATURES**

1. PRESENTING THE “RENAULT MAGNUM E-TECH” SERIES

Make-up of the series

RENAULT MAGNUM E-TECH 4x2 rigid 18/19 tonnes:

- 6 wheelbases (5045, 5375, 5705, 6035, 6365, 6695 mm)

RENAULT MAGNUM E-TECH 6x2 rigid 26 tonnes:

- 5 wheelbases (4385, 4715, 5045, 5375, 5705 mm)

Depending on your vehicle's equipment

Engine:	MIDR 06.24.65 - A66 / B66 / C66 - cubic capacity 11,929 cc - 3 power levels (400, 440, 480 hp)
Clutch:	430 DTE MFZ 2.400
Gearbox:	ZF 16S 181 ZF 16S 221 ZF ASTRONIC
Power take-off:	S81Z1 B/C (NH.1B/C) S84Z1 B/C (NH.4B/C) N221-10.B/C
Propeller shafts:	Tubular shafts with universal joints
Front axle:	E81
Rear drive axle:	P 1345 P 1370 PMR 2141 With inter-axle and inter-wheel differential locks.
Lift-up axle:	ER 8 ER 11
Self-tracking lift-up axle:	AUSTERAS
Steering:	ZF 8098 With incorporated hydraulic power assistance
Front suspension:	Leaf springs, hydraulic shock absorbers and anti-roll bars

Rear suspension:	Leaf springs, hydraulic shock absorbers, anti-roll bars and air springs Air suspension Pivot-mounted oscillating leaf springs
Brakes:	All air "EBS" braking system
Retarders:	Exhaust brake Electric retarder Jake engine-brake ZF hydrodynamic "INTARDER"
Electrics:	24 Volts current 2 batteries 190/230 Ah Alternator BOSCH NL1 80A Starter MITSUBISHI P 105 D

IMPORTANT

*Vehicle equipped with "EBS" electronic braking system :
The alternator and the batteries form part of the system and their characteristics are integrated in the vehicle type approval dossier. For any modifications, refer to your dealer or the nearest approved agent.*

1.1 Electronic management of “RENAULT MAGNUM E-TECH” vehicles

1.1.1 Operating principle

Engine electronic management is used to improve engine performance while optimizing fuel consumption and pollutant emissions (in order to meet Euro 3 standard).

The electronic system consists of two principal electronic control units:

- the **EECU** (Engine Electronic Control Unit):

This is located on the engine and manages, among other things, the fuel pump solenoid valves, the exhaust brake... on the basis of information it receives from the different engine, speed, air temperature, fuel pressure... sensors.

- the **VECU** (Vehicle Electronic Control Unit):

This is located behind the dashboard can-holder and manages operation of the different vehicle equipment items (windscreen wash/wipe...), controls (accelerator, parking brake, electric retarder...), as well as the “bodybuilder” functions (PTO, related engine speeds...).

An instrument panel display (AFFI 2000) makes the interface between vehicle and driver. Not only classic information such as distance travelled, average or instant fuel consumption... is displayed, but also information on the state of the vehicle or its body (tailgate incorrectly closed, interior lighting in service...), coupled in case of danger with the STOP warning light or a buzzer.

All these modules are interlinked by a digital communication bus (CAN bus) that allows them to exchange the necessary orders and information.

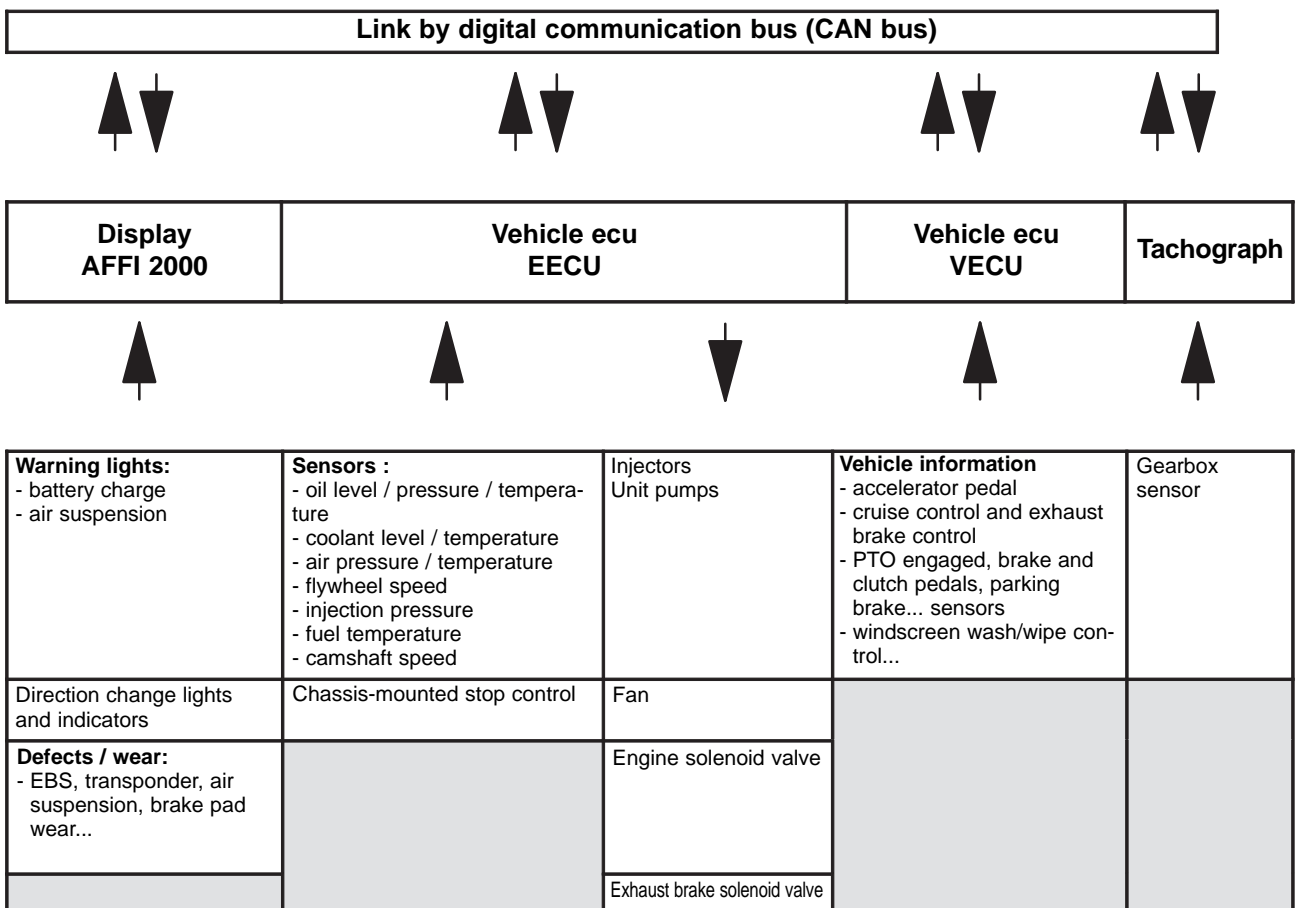

It is forbidden to cut the engine ECU wiring harness located in the battery compartment (for extension or shortening purposes).

Any changing in position must be done in an area permitted by range of movement of the wiring harness - take care to protect the ECU against splash and spray.

1.1.2 Bodybuilders' electrical pre-arrangements

The vehicle electrics are managed by the vehicle electronic control unit (VECU).

For a detailed description of the electrical pre-arrangements, see the "Electrical pre-arrangements" chapter.

1.2 Warning

Any work on the fuel system is forbidden.



On engines equipped with common rail fuel-injection operating at very high pressure, the presence of air may lead to damage to the pump.

Observe the rules governing common rail system cleanliness and bleeding, that is to be performed whenever any work is carried out on the system.

For further information, consult the RENAULT TRUCKS Product Applications Department.

On the low pressure circuit, changing of position of a fuel tank, adding unions or components, risks creating extra head losses:

- The specification risks not being met both at supply pump inlet and at pump return.
- The pressure regulation device risks malfunctioning (the system is sensitive to head losses).
- Check the air take-offs, make sure the fuel level is correct even when the vehicle is on an incline and during the brake application phases (difficulty in starting or stalling of the engine).
- The fuel filters must still be the last part before the HP pump inlet.
- The position of the prefilter must still be the same on the hydraulic circuit (between the injector return and the feed pump inlet).



On account of the use of electronic boxes, the installation of equipment may cause electromagnetic disturbance and oblige bodybuilders to proceed with new approval of the vehicle in respect of Electromagnetic Compatibility.



The engine speeds in PTO mode are managed by the electronics.

For trade vehicles, the subsequent installation of electrical pre-arrangements requires significant and complex intervention work (installation of cab and chassis wiring harnesses, re-definition of vehicle and engine ECU parameters...).



It is forbidden to walk on or place heavy articles on the engine for risk of damaging the HP injector pipes and the plastic rocker covers.



Guarantee access to the air intake, exhaust and fuel supply circuits.

The radiator inlet and outlet surfaces must not be modified.

The cooling flows must be conserved.

2. GENERAL REMARKS ON THE “RENAULT MAGNUM E-TECH” SERIES

2.1 Identification of the vehicle

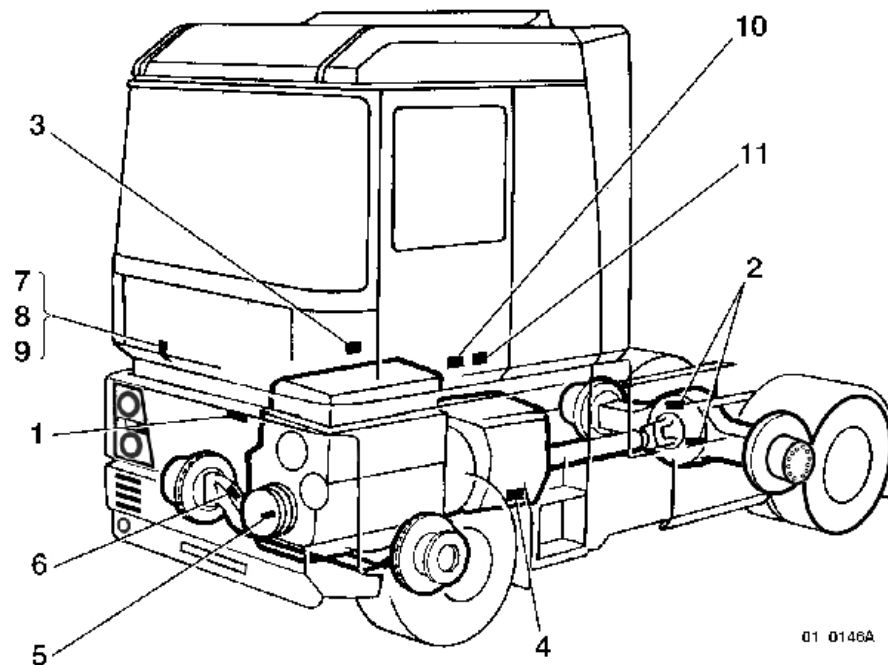

01 0146A

Depending on your vehicle's equipment

- 1 - Chassis
- 2 - Rear drive axle
- 3 - Tachograph plate
- 4 - Gearbox
- 5 - Engine
- 6 - Axle
- 7 - CAM reference
- 8 - Paint reference
- 9 - Manufacturing number
- 10 - Manufacturer's plate
- 11 - Conformity plate

IMPORTANT

The identification markings must remain visible and accessible without need for removing any body-work component.

2.2 General drilling principles

2.2.1 Drilling cab panels for fitting accessories

This allows access to sealed crimping nuts for the assembly of accessories.

The recommendations below will help avoid damage to the roof headlining at the time of drilling.

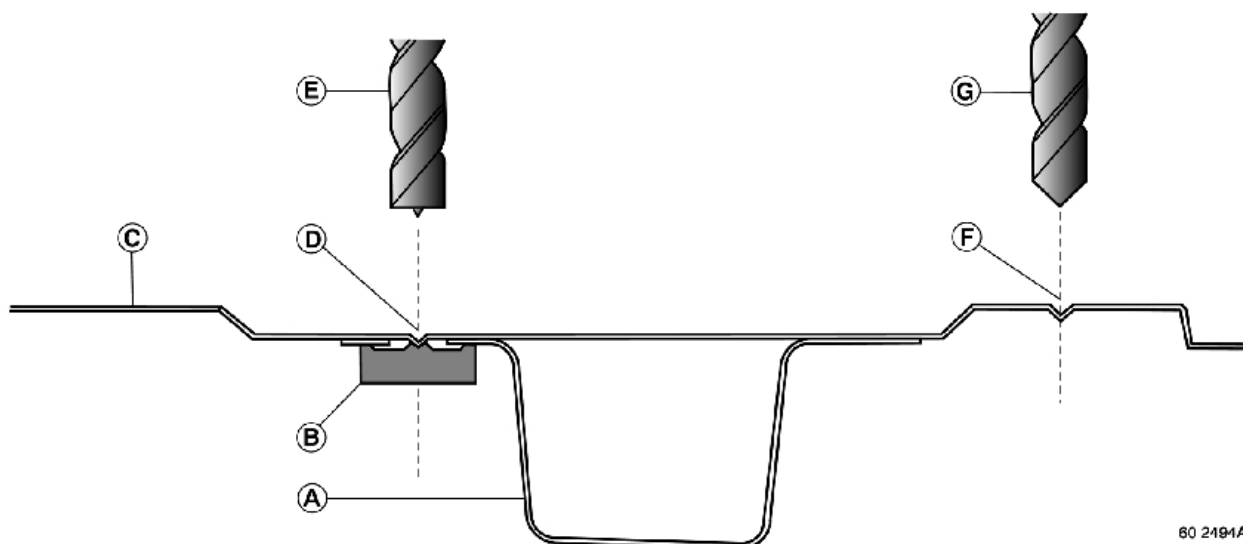

80 2191A

- A - Roof stiffener
- B - Weld nut on stiffener
- C - Bodywork panel
- D - Positions of impressions for drilling and access to weld nut
- E - Centring drill with stop:
 - dia. 11 mm for crimping nut dia. 8 mm
- F - Positions of impressions for drilling and access to crimping nut
- G - Centring drill with stop:
 - dia. 9 mm for crimping nut dia. 6 mm

For details on tools and crimping nuts: see "Addition of equipment to the bodywork" chapter.

Anti-corrosion protection:

Deburr the holes after drilling.

Protect the metal with a zinc aerosol spray available from the Spare Parts Department, ref. N° 77 01 406 425.

2.2.2 Drilling in sidemembers



- No drilling in the flanges of sidemembers,
- No drilling more than 3 holes on the same vertical.

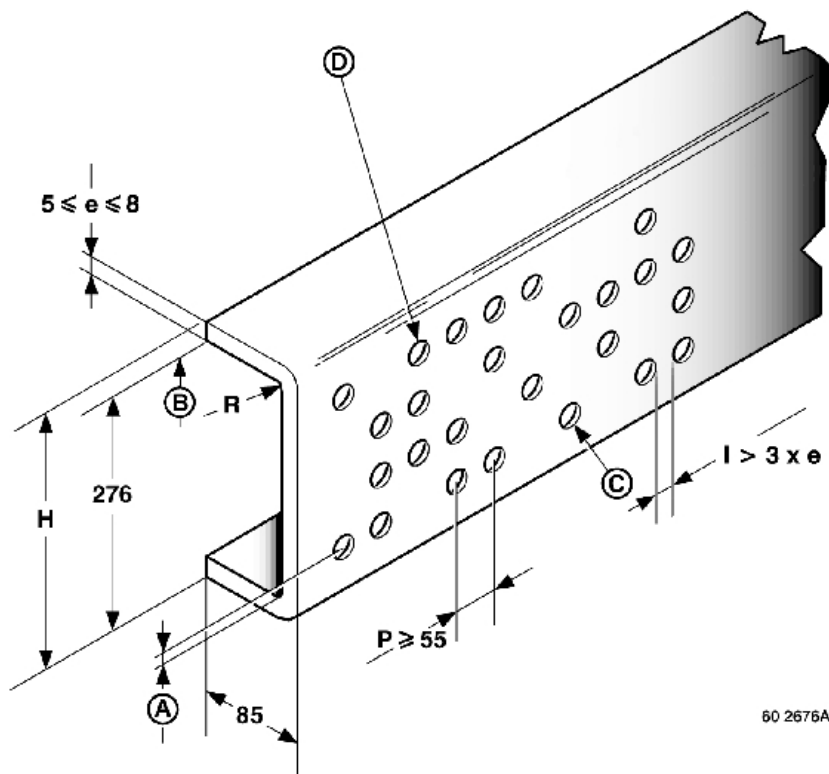

60 2676A

- B - Chassis zero (RENAULT TRUCKS reference axis),
- e - Sidemember thickness,
- P - Between-centres distance between two drillings,

All the drillings must be at a minimum distance from the sidemember flanges: $A > R + 3 \text{ mm} + F$

R - sidemember internal radius of curvature.

F - diameter of washer or diameter of rivet head divided by two,

C - Maximum authorized drilling diameter:

- 13 mm for a 12 mm screw
- 15 mm for a 14 mm screw
- 17 mm for a 16 mm screw

D - Alignment of 3 holes maximum on the same vertical axis,

H - $276 + 2e$,

l - Minimum width between 2 drillings,

Anti-corrosion protection and paint retouches to the chassis

Protect the metal with a zinc aerosol spray, ref. N° 77 01 406 425.

Retouch paintwork with a grey chassis aerosol paint spray, ref. N° 50 01 848 147.

These consumables are available from the RENAULT TRUCKS Spare Parts department.

2.3 Precautions prior to welding

2.3.1 Protection of wiring harnesses



When welding or using a disk sander, take care to protect electrical wiring harnesses and air pipe bundles against any spatter that might damage them.

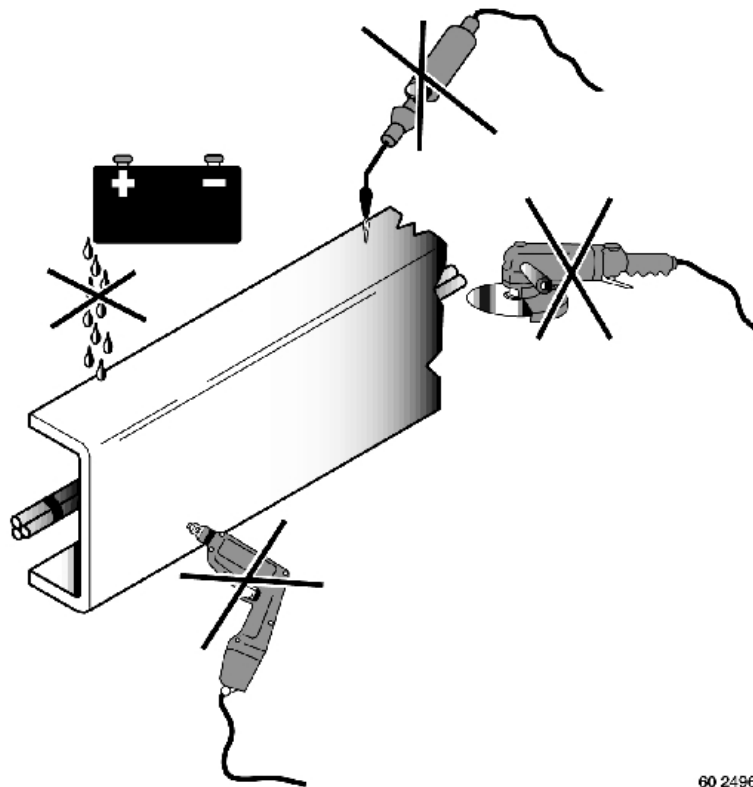

60 2496A

2.3.2 Welding on vehicles equipped with a master switch



Important operations to be carried out without fail, prior to welding.

The vehicle is equipped with numerous electronic circuits and numerous electronic control units (ECU). Before any operation involving electric welding, potentials must be eliminated by connecting the ECUs to earth. This can be quickly done by connecting the battery positive (+) cable to earth and then closing the master switch, if fitted.

Place the earthing clamp as near as possible to the point of welding, but never on rotating parts (prop shaft, fan hub, etc.) nor on a sub-assembly having moving parts (i.e. air compressor, turbocharger, etc.)

Nearby plastic pipes and electrical cables, springs and air-suspension bags are to be protected or removed. This also applies when grinding or drilling.

DIAGRAM: Vehicle without master switch

I – Initial state

II – State before welding

A – Batteries

(1) Disconnect the positive (+) cable and the negative (-) cable from the batteries.

(2) Connect the positive (+) cable and the negative (-) cable to earth.

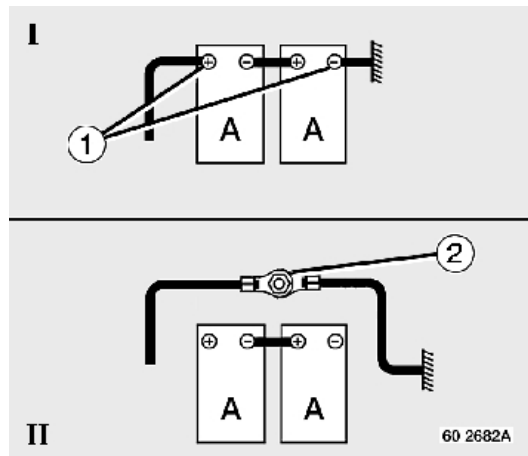

Diagram: Vehicle with mechanical master switch

I – Initial state

II – State before welding

A – Batteries

B – Mechanical master switch

(1) Disconnect the positive (+) cable and the negative (-) cable from the batteries.

(2) Connect the positive (+) cable and the negative (-) cable to earth.

(3) Close the master switch.

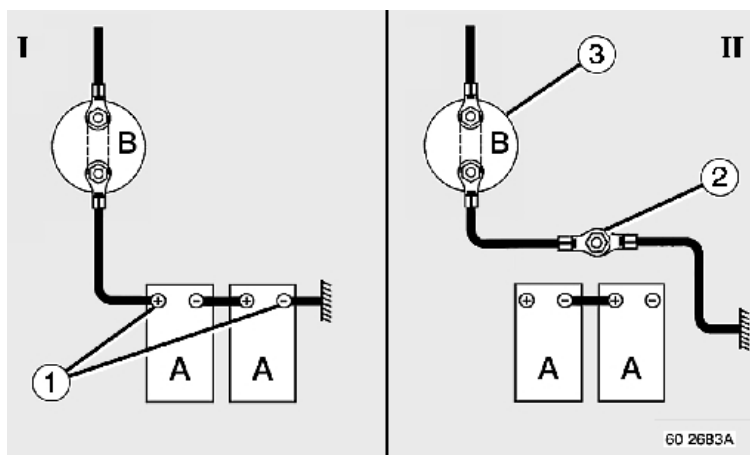

Diagram: Vehicle with electrical master switch

I – Initial state

II – State before welding

A – Batteries

B – Electromagnetic master switch

a – Battery earth

b – After master switch positive (+)

c – To engine immobilizer (master switch control)

d – Before master switch (+)

(1) Disconnect the after master switch positive (+) feed cable.

(2) Disconnect the positive (+) cable and the negative (-) cable from the batteries.

(3) Connect the positive (+) cable and the negative (-) cable to earth.

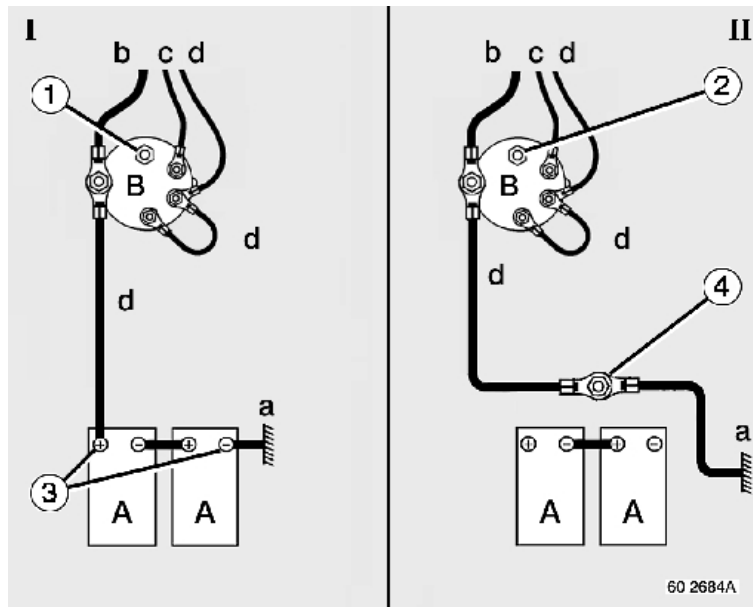

After welding, reconnect all the cables finishing with the earth cable (a).

Other precautions before welding: refer to chapter "Precautions before welding" in the "General Features" section.



The use of any other system for disconnecting the batteries (e.g. installation of a capacity between the battery terminals) is not recommended.



When welding in the cab, place the earthing clamp as close as possible to the point of welding.



Welding should be an exceptional operation on our vehicles (extension of chassis, welding of crane masts or booms...).



When installing wiring harnesses, pay attention to hot spots (exhaust, turbocharger, electric retarder).



Bodybuilder wiring harnesses can be routed parallel to those of the vehicle, but with independent fasteners (do not tie up or fasten bodybuilder wiring harnesses to vehicle wiring harnesses).



Pay attention to movement of the cab at articulation level when installing wiring harnesses connecting the chassis to the cab.



Do not open the mechanical master switch while the engine is running.

2.4 Minimum load on front axle

In order to guarantee suitable vehicle ride behaviour, stability and handling under maximum safety conditions, the minimum load on the front axle must be applied whatever the vehicle load and equipment conditions.

For special cases, consult the RENAULT TRUCKS Product Applications Department.

IMPORTANT

- Never exceed the maximum permissible load on the front axle.
- Application of the load in the rear overhang of the vehicle is detrimental to vehicle ride behaviour, stability and handling. Great prudence is recommended when driving under such conditions.
- Watch that the centre of gravity of the load is positioned laterally as close as possible to the centre of the vehicle.

2.5 Soundproofing screens and heat shields

2.5.1 Instructions for soundproofing screens

Soundproofing screens should neither be removed, modified nor displaced so as not to downgrade the vehicle sound level, which is covered by official homologation.

If it is unavoidable for them to have to be removed, they must without fail be put back into place when the work is completed.

After removal, only perfectly clean screens should be refitted.

The screens are to be cleaned using a cloth. If necessary, use soapy water (all other products are to be forbidden).



No solvents or paints are to be applied at all on either the inner or the outer faces of soundproofing screens.

Any damage to the internal protective film of the screen requires the screen to be replaced.

In the event of on-vehicle welding or the use of a sanding disk, provide efficient protection to the screens.

If the screens have been removed, provide efficient protection to the wiring harnesses.

Pay particular attention that there are no inflammable products present on the screen protective films.

Overtightening of screen attaching nuts and bolts may lead to damage.

Observe the recommended tightening torques without fail.

- screen bracket / chassis fastenings: 20 Nm \pm 20%

- screen / chassis bracket fastenings: 8 Nm \pm 20%

2.5.2 Instructions for heat shields

It is forbidden to remove or modify these shields. They play a part in the safety of your vehicle.

During chassis painting operations, take care to efficiently protect the hot face of heat shields against splashing paint and especially the shields surrounding the electric retarder. In effect, these shields are only effective if the surfaces are free from any foreign matter.

2.6 Side impact guards

Side impact guards must comply with the laws in force and should not impede access to chassis components (spare wheel, air and fuel tanks, air dryer...).

3. INSTALLATION OF BODYWORK

3.1 Use of 1/20th scale drawings and calculation sheets

Technical data sheets are tools used by sales engineers to present the range or series. They are not representative of particular vehicles.

To obtain precise information, refer to the 1/20th scale drawings, calculation sheets or type approval department reports to be found on the website "www.renault-trucks.com" under RENAULT MAGNUM E-TECH.

Only these documents will give you accurate and reliable information on vehicles as regards tonnage, wheel-base, air intake, cab type, weights...



Refer to the following, without fail:

- Cab accompanying drawings (footprint, tilting radius...).
- Chassis accompanying drawings (position of appliances...).

3.2 Sub-frame sections

3.2.1 Sub-frame minimum height

A minimum sub-frame height is imposed by the range of movement of the rear suspension. The use of a sub-frame with insufficient height would result in possible damage to the underbody or equipment due to friction by the rear wheel tyres.

IMPORTANT

- Do not modify the ECAS standard fitment adjustment levels.

3.2.2 Sub-frame minimum inertia

Sub-frame	Sub-frame minimum inertia (mm ⁴)
	Along axis (X)
120x70x7	63800
100x70x7	49890
60x70x7	24970

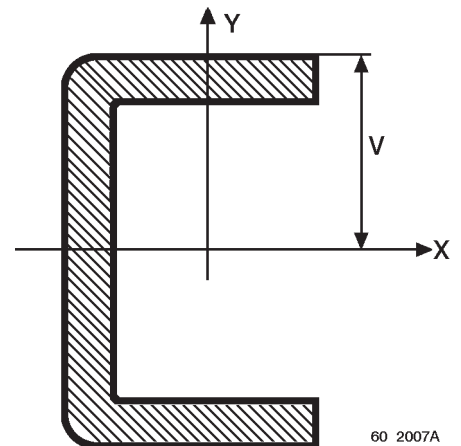

60 2007A

Reminder of formula for calculating maximum normal surface stress

$$\sigma = \frac{Mf}{\left(\frac{I}{v}\right)}$$

σ : maximum stress at surface edge (N/mm²)

Mf : bending moment (Nm)

I : surface quadratic moment (mm⁴)

v : distance between section extremity and neutral fibre (mm)

3.3 Lateral guiding

All bodies must be fitted with lateral guides to the front and rear of the sub-frame.

At the front:

For vehicles fitted with flush first brackets, lateral guiding must be assured by two guide plates that are:

- welded to the sub-frame,
- bolted to the sub-frame or the chassis, but never both at the same time.

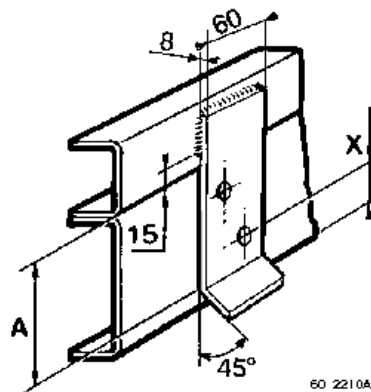

For vehicles fitted with raised first brackets, the latter play the part of front guides. The fitting of guide plates is therefore unnecessary.

At the rear:

Lateral guiding must be assured by two guide plates. These are drilled and screwed to the sidemembers if they also fulfil the function of inertia stop.

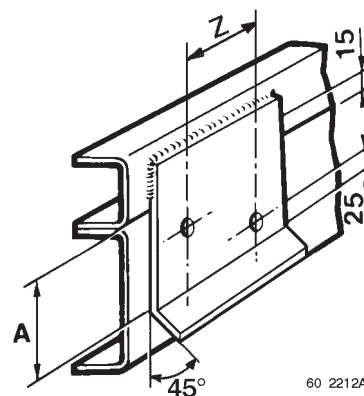
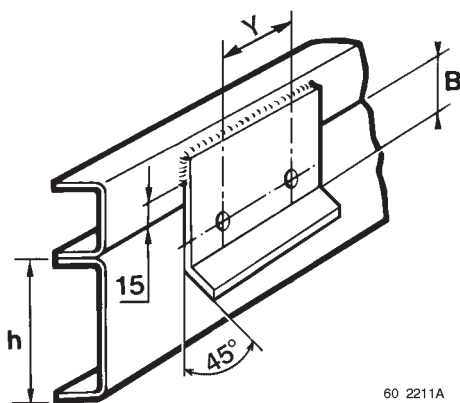

For positioning the drillings to the guides, observe the sidemember drilling recommendations described in the chapter "Drilling of sidemembers".

A: minimum support height, 3/4 of height (**h**) of the sidemember

B: minimum support height, 1/4 of height (**h**) of the sidemember

X (mm)	Y (mm)	Z (mm)
75	55	55

Inertia stop

All bodies or equipment must be fitted with an inertia stop to the rear of each sidemember to retain the body against motion.

When the vehicle is fitted with a tailgate, the flanks play the part of inertia stop.

3.4 Attachment of bodywork

It is essential to comply with the stipulations hereafter for attaching bodywork of equipment to our vehicles. For special cases, contact the RENAULT TRUCKS Product Application Department.

The bodywork must be correctly attached so that both the static and dynamic stresses are freely transmitted without causing excessive local strain, which could prejudice the reliability of the chassis frame or affect the road behaviour of the vehicle.

The use of brackets mounted in production to the chassis is compulsory.

Attachments to bodywork sub-frame or underbody must without fail be carried out according to recommendations defined in this document (consult the "Types of fastening" chapter).

Sub-frames or underbodies must without fail form a flat seat over the entire length of the chassis. They may however be discontinuous for certain specific applications (e.g. tankers) - in such case, the bodybuilder shall be fully responsible.

The shape of sub-frames or underbodies must be degressive towards the front, under the back of the cab, so as to avoid sudden variations in inertia.

Protection against heat radiation: the closeness of the bodywork to the exhaust pipe and the fitting of certain accessories (electric retarder, etc...) may require the installation of a suitable heat shield by the bodybuilder.



BANS

WE FORBID:

- Attachment of sub-frames by U-bolts, clamps or equivalent systems (hooks).
- Use, drilling or welding of spring hangers.
- Any modification to: chassis, driveline, suspension (except if contained in the Guide for Fitting Bodywork).
- Attachment of sub-frames by welding to sidemembers.
- Drilling of stiffener gussets.
- Welding, notching of sidemembers, gussets or cross-members.
- Use or modification of our nut and bolt hardware for the attachment of a body or a sub-frame (except for special cases specified in this document).
- Dismantling of brackets attached to the chassis (unless specified otherwise in this document).
- Insertion of wooden blocks between sub-frames and the chassis.

3.5 Attachment of sub-frames to brackets

3.5.1 Types of fastening

- 1 - Flexible attachment (first bracket)
- 2 - Rigid attachment (all other brackets)

Guiding and fastening zone

The part known as "lateral guiding or elastic fastening zone" corresponds to a part of the chassis in which distortion is produced during dynamic stress, rolling, manoeuvring of the equipment of the vehicle (tipper, platform, van, tanker, etc...). The link(s) situated in this zone must absorb these phenomena while maintaining a reliable link between chassis and equipment

- A - Lateral guiding and elastic fastening zone
- B - Guiding and rigid fastening zone
- C1 = 1702.5 mm - Flexible attachment position (first bracket)
- X - Front axle centre-line

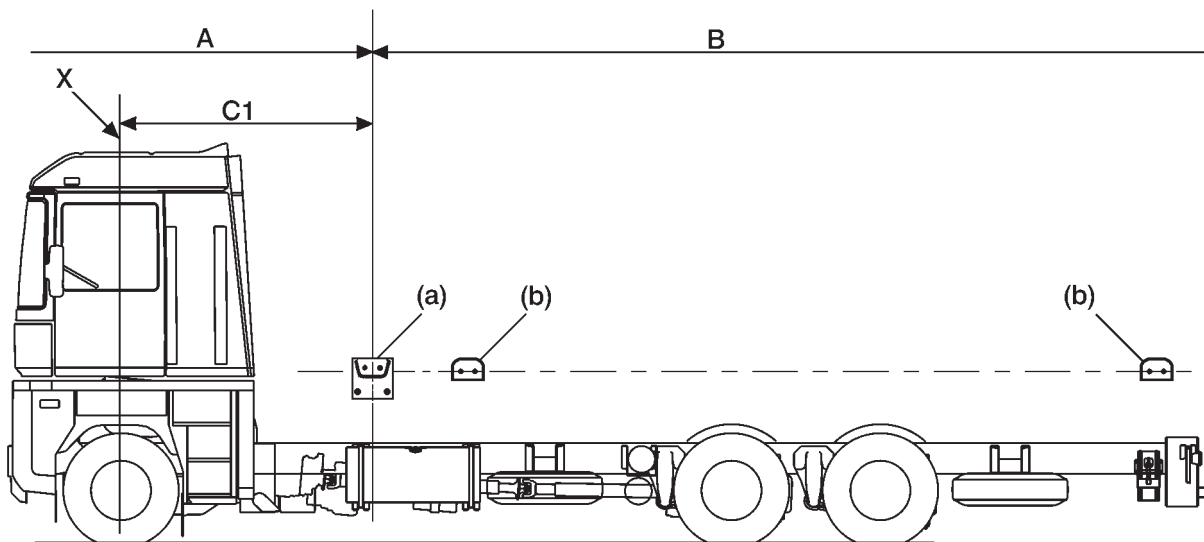

60 1054B

A - Flexible attachment

- 1 - Hexagon bolt M 14 x 150 x 140, class 10.9
- 2 - 3 plain washers 14 x 30 x 5
- 3 - 6 spring washers:
 - i/d 14.5 mm
 - o/d 35 mm
 - thickness 1.8 mm
 - unit preload 400 kg
- 4 - Nut DRH M 14 class 10, or other locknut except nut with nylon ring (e.g. Nyloc)

Tightening:
 Place nut (4) in contact with spring washers (3) by hand, then tighten mechanically as far as crushing of the spring washers by 3 to 4 mm.

Note
 An equivalent fastening technique solution is permitted (e.g. rubber sandwich mounting), if it keeps the same preload.

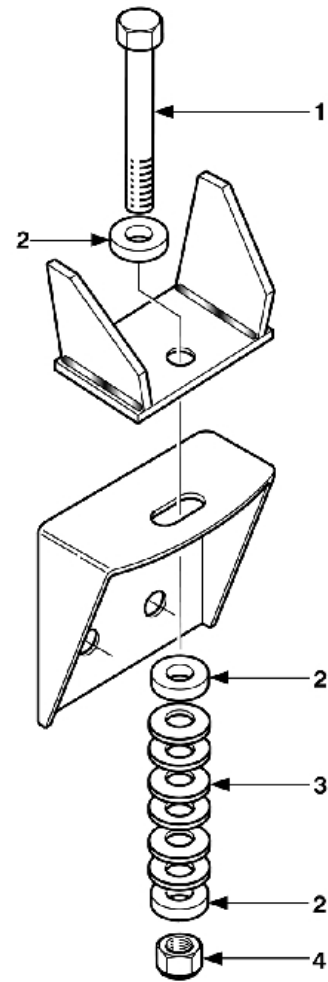

60 2560A

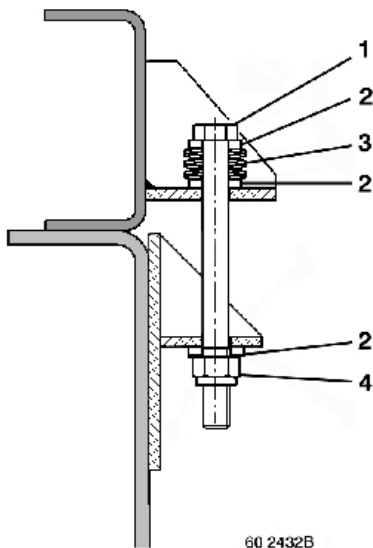

60 2432B

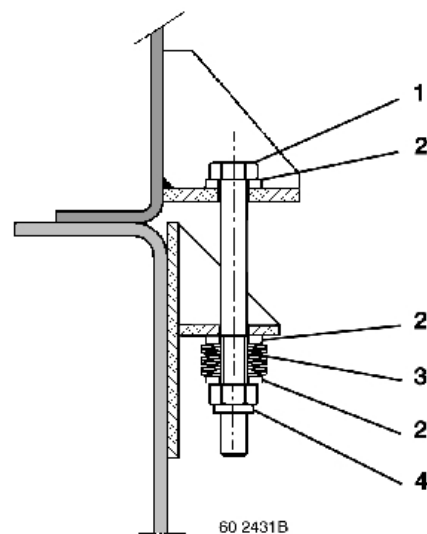

60 2431B

B - Rigid attachment

- 1 - Hexagon bolt M 14 x 150 x 50, class 10.9
- 2 - 2 plain washers 14 x 30 x 5
- 3 - Nut DRH M 14 class 10 or other locknut except nut with nylon ring (e.g. Nyloc)

Tightening torque: 170 Nm

Flush brackets (b) (See chapter B-3.54.2).

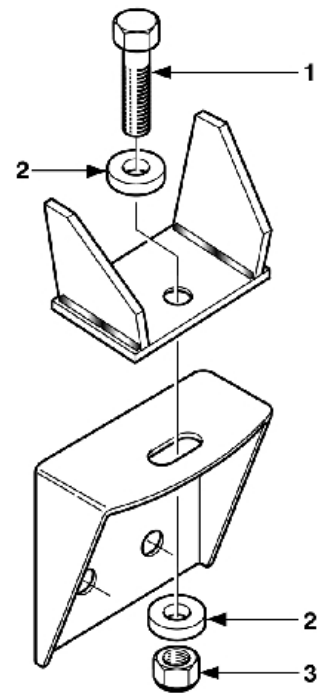

60 2561A

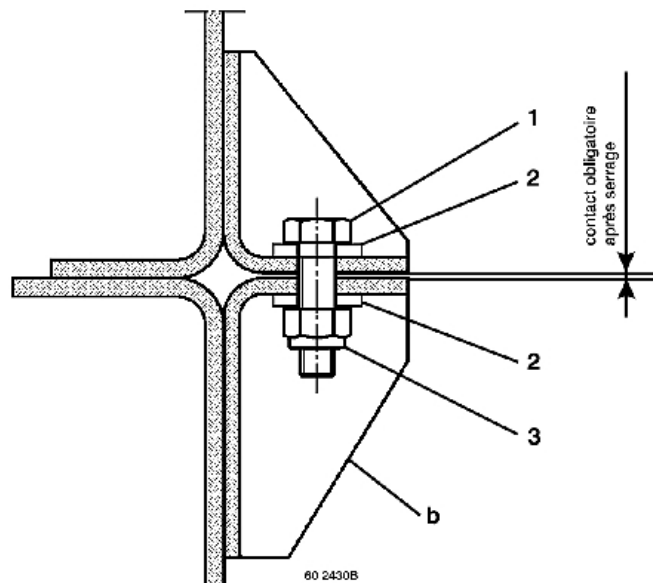

60 2430B

3.5.2 Vertical positioning of brackets

Two bracket assemblies are made on the RENAULT MAGNUM E-TECH chassis:

- The first bracket (a) is different from the other brackets (b).
- The size of the slotted hole is the same for all the brackets.

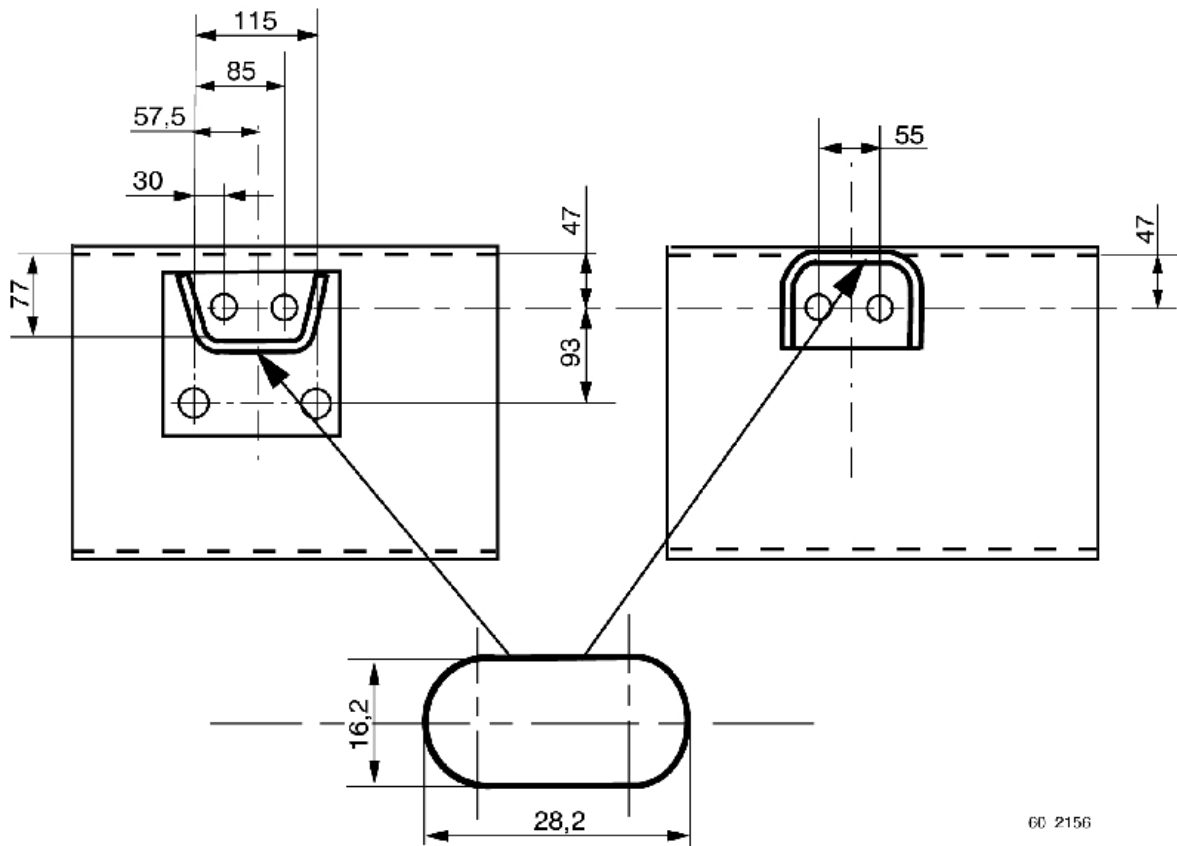

00 2156

3.5.3 Longitudinal positioning of brackets on chassis

4x2 rigid

Dimensioning items	Wheelbases					
	5045	5375	5705	6035	6365	6695
A	6310	6860	7400	7565	8095	8460
B	2545	2765	2975	2810	3010	3045
C5	660		715	1045	715	1045
C6	825	1100	1045	760	925	940
C7	1085	1140	865	975		865
C8	-		605	1100	1155	880
C9	-					715
C10	825	1100		825	1100	
D1	1195		-			
D2	-		2175	1955	-	
D3	1965	2240	2560	2230	2575	2410
E	5045	5375	5705	6035	6365	6695
F	8756	9306	9846	10011	10541	10906
G1	2530	2860	3190	3520	3850	4180
G2	-		1745	-	2340	1965
G3	1665	1775	2105	2050	2380	2490
H1	2282,5	2612,5	2942,5	3272,5	3602,5	3932,5
H2	1277,5		1332,5	1277,5	1717,5	1387,5
H3	-		1747,5	1692,5	1857,5	2132,5
J	2570	2790	3000	2835	3035	3070
K	2950			2980	2950	
L	770		825	1155	825	1155

(*) For the values of the dimensions, consult the calculation grids on the website "www.renault-trucks.com" under RENAULT MAGNUM E-TECH.

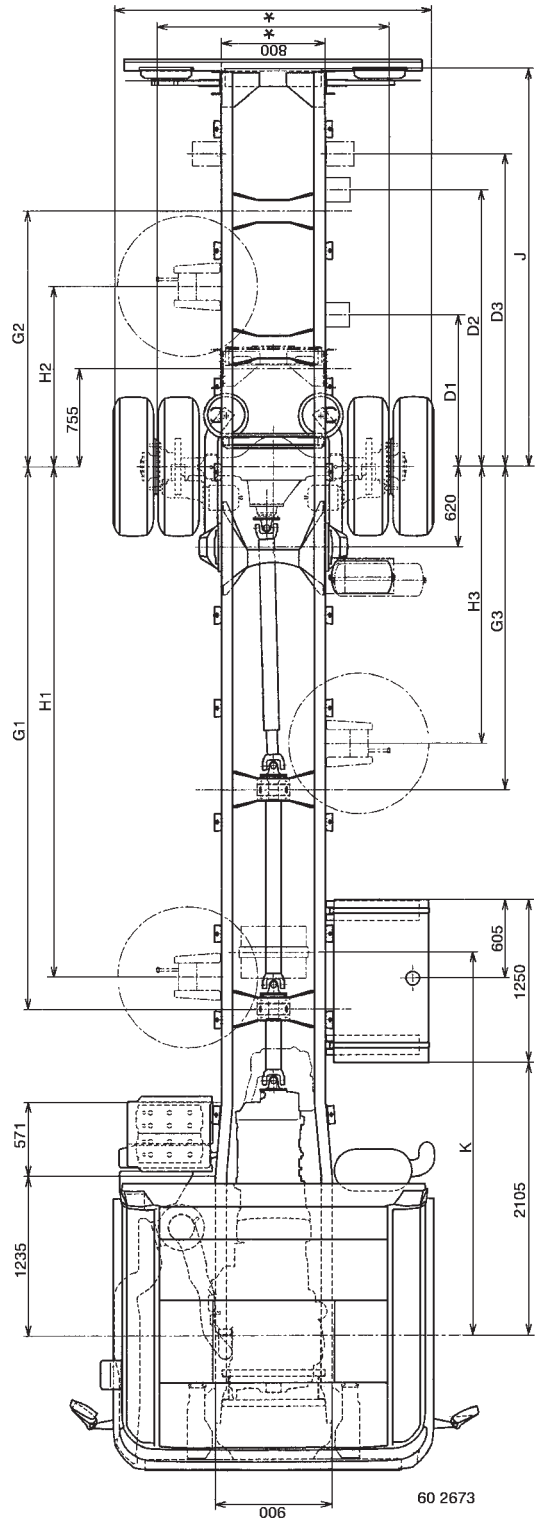
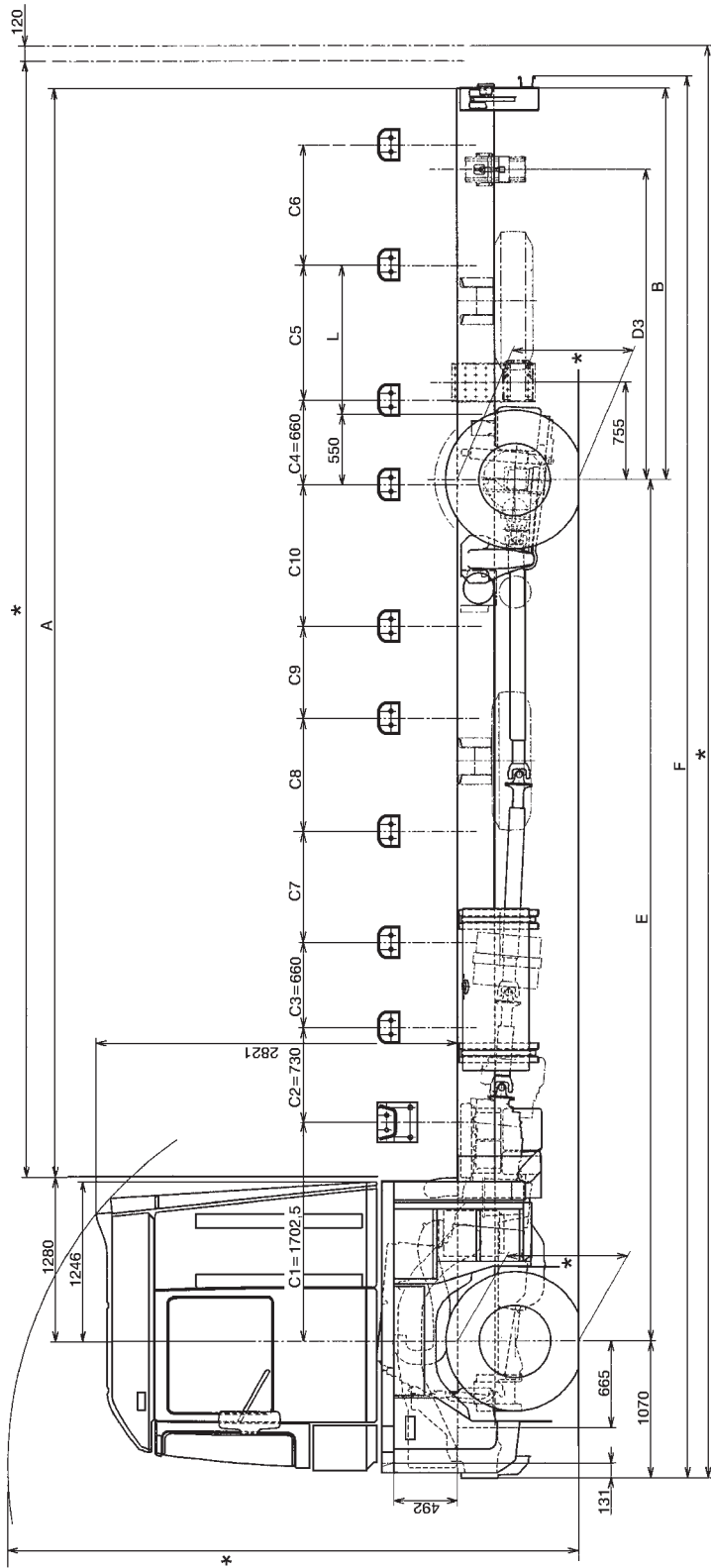

6x2 rigid

Dimensioning items	Wheelbases				
	4385	4715	5045	5375	5705
A	6530	7130	7760	8180	8760
B	2035	2310	2605	2695	2945
C5	1140		760		975
C6	770	880	545		880
C7	-		880		825
C8	-			660	
C9	-	660		865	
C10	1085	755	1085	550	880
D1	2075	-			
D2	-	2955	-		
D3	2955	3230	3525	3615	3890
E	4385	4715	5045	5375	5705
F	8980	9585	10210	10630	11210
G1	1870	2200	2530	2860	3190
G2	-			3285	2955
G3	-		1665	1775	2105
H1	1622,5	1952,5	2282,5	2612,5	2942,5
H2	-				1747,5
J	3450	3725	4020	4110	4360

(*) For the values of the dimensions, consult the calculation grids on the website "www.renault-trucks.com" under RENAULT MAGNUM E-TECH.

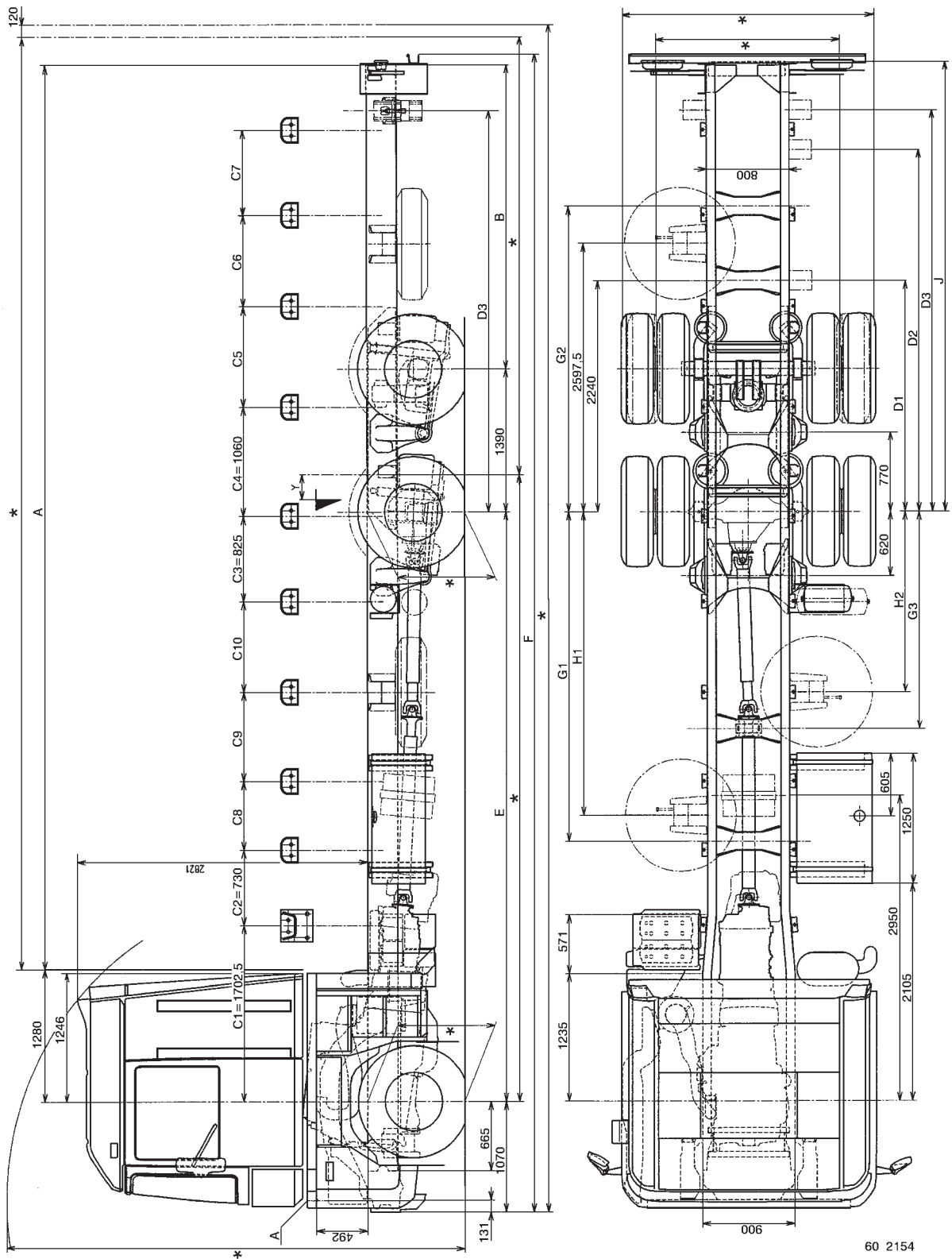

60 2154

M = Max. body width

(*) For the values of the dimensions, consult the calculation grids on the website "www.renault-trucks.com" under RENAULT MAGNUM E-TECH.

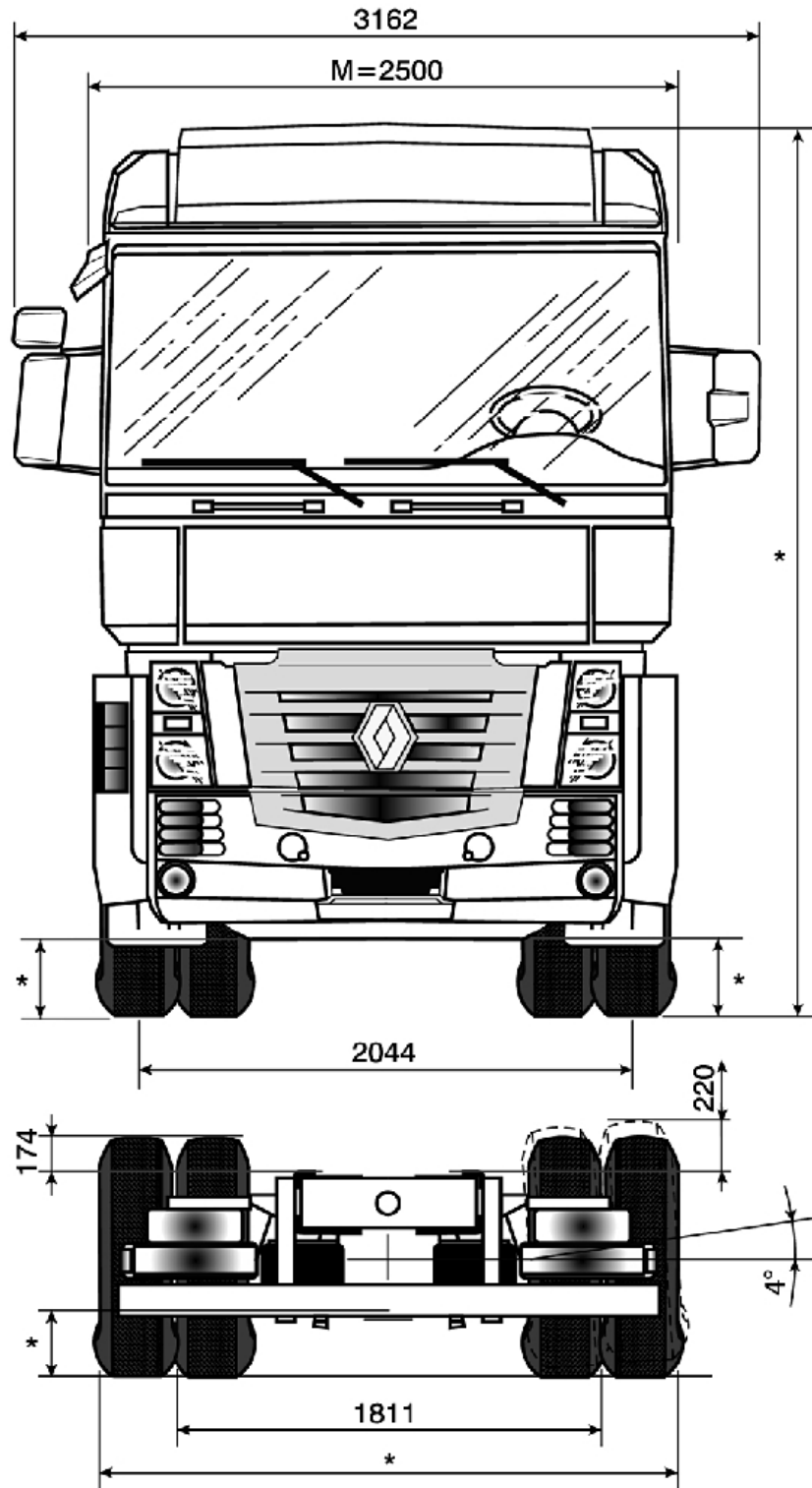

60 2674A

3.6 Vertical exhaust

- A – Maximum footprint
- X – Front axle centre-line

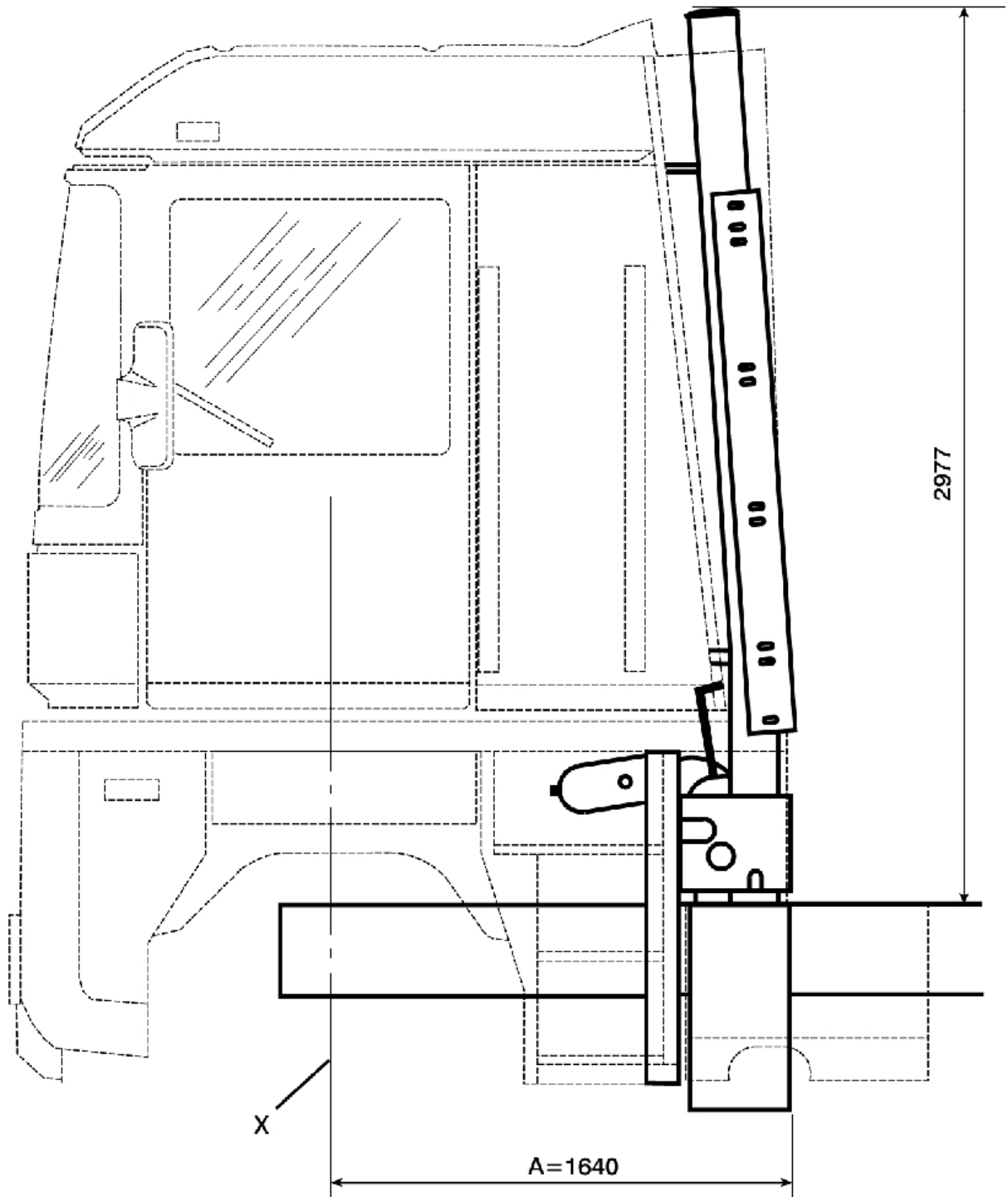

60 2685A

ELECTRICAL PRE-ARRANGEMENTS

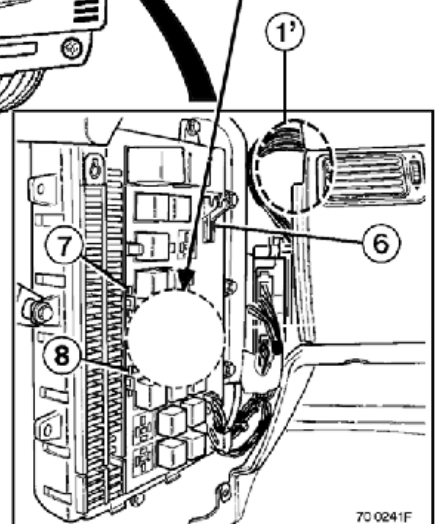
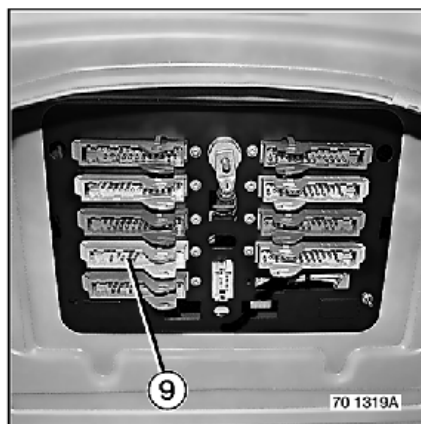
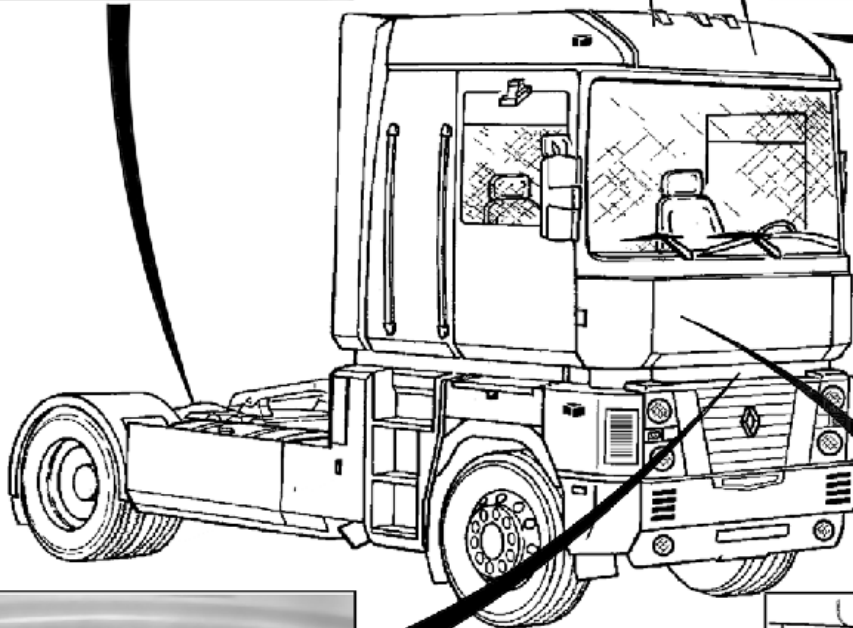
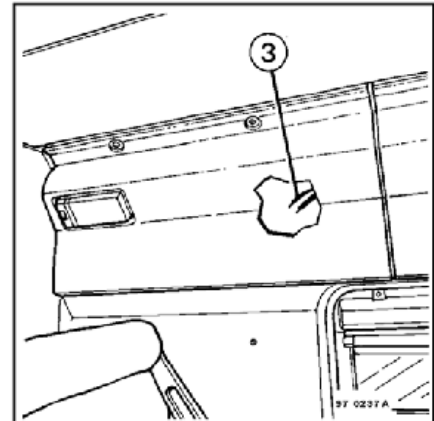
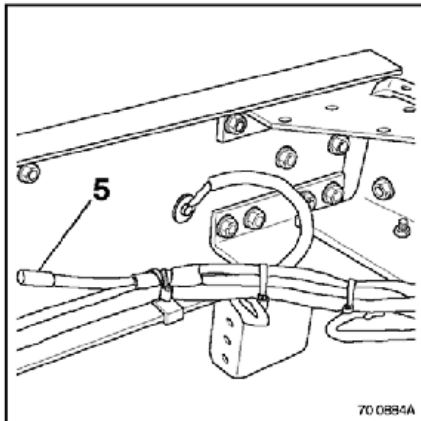
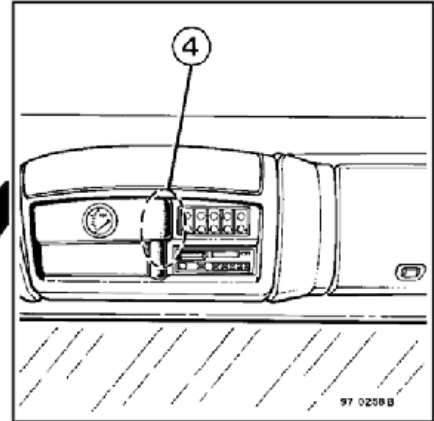
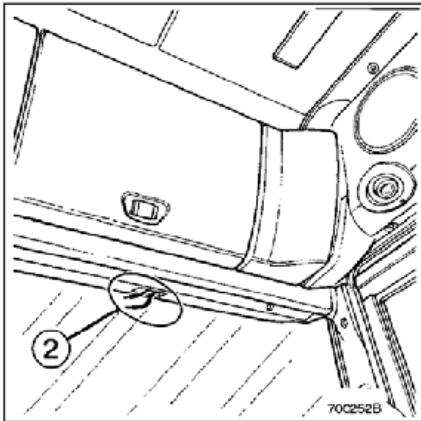

4. ELECTRICS

4.1 Available power supplies

The electrical pre-arrangements are necessary to obtain certain functions (e.g. special machine warning light) and contribute towards improved assembly quality for optimized cost price.

Any electrical connection must mandatorily be made to the available power supplies made available by RENAULT TRUCKS.

It is forbidden to make any electrical tapping to the different wiring harnesses on the vehicle.

Use and adapt the connectors and wiring harnesses approved and distributed by RENAULT TRUCKS.

The cable sections must be adapted to the required use (5 Amps per mm²).

Comply with the circuit protections recommended by RENAULT TRUCKS

It is forbidden to change the rating of the fuses.

Location	Connector	Wire	Assignment	Fuse	Rating
1: Dashboard near "BFR" (cab interior) 1': -	2 insulated wires on stand-by insulated wires on stand-by	46 155	+ 12V available power supply (radio-telephone) - available power supply (radio-telephone) Radio-telephone antenna cable	-	-
2: Passenger side top ledge (cab interior)	2 insulated wires on stand-by	1 632	Earth Available power supply (lighting)	F5	10A
3: Driver side roof (cab interior)	2 insulated wires on stand-by	1 473	Earth Available power supply (video)	F53	10A
4: Driver side top ledge (cab interior)	6 insulated wires on stand-by	1 4000 144 24 64 72	Earth + 12V available power supply (CB) - available power supply (CB) Available power supply (after ignition) Available power supply (lighting) Available power supply (front air pressure)	- - F16 F6 -	- - 10A 10A -
5: Chassis rear RH side-member	4 insulated wires on stand-by	208 275 632 0403	Available power supply (after master switch) Available power supply (after ignition) Available power supply (lighting) Rigid perimetric protection module	F21 F35 F5 -	15A 10A 10A -

Available power supplies (cont.)

6: Connection unit "BFR"	Location for brown 16-way JPT clip-holder ref. N° 5010214710	1	Earth	F6	10A		
		64	Available power supply (lighting)				
		960	Available power supply (after ignition)			F55	10A
		961	Available power supply (relay 17)				
		962	Available power supply (relay 17)				
		963	Available power supply (relay 47)				
		964	Available power supply (after master switch)			F40	10A
		965	Available power supply (relay 47)				
		966	Available power supply (relay 47)				
		967	Available power supply (relay 48)				
968	Available power supply (relay 48)						
7: "Connection unit "BFR"	Location for grey 2-way connector ref. N°5010293074	1	Earth	F21	15A		
208	Available power supply (after master switch)						
8: "Connection unit "BFR"	Location for black 2-way connector ref. N° 5010293073	1	Earth	F35	10A		
275	Available power supply (after ignition)						
9: Bulkhead grommet	Location for white 25-way JPT clip-holder ref. N° 5010214712	045	Available power supply (after engine speed +)	–	–		
		047	Available power supply (after engine speed -)	–	–		
		88	Available power supply (PTO)	–	–		
		208	Available power supply (after master switch)	F21	15		
		618	Available power supply (lighting)	F21	15		
		651	Available power supply (equipment work position "Alert" warning light)	–	–		
		1025	Available power supply (after engine speed)	–	–		
		1026	Available power supply (PTO)	–	–		
		1141	Available power supply (PTO)	–	–		
		8083	Available power supply (bodybuilder equipment control)	F21	15		
		8084	Available power supply (handrail deployed "Alert" warning light)	–	–		
		8067	Available power supply (fast idling control)	–	–		

Location 6:

C970 – available power supplies (relay)

Parts to be used, available from the RENAULT TRUCKS Spare Parts Department:

- brown 16-way JPT clip-holder ref. N° 50 10 214 710
- clips:
- wire section 0.6 to 1 mm² ref. N° 50 10 214 345
- wire section 1 to 1.2 mm² ref. N° 50 10 214 346

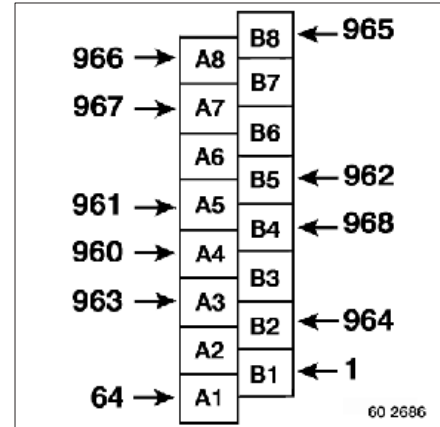

Location 7:

C972 – available power supplies (after master switch)

Parts to be used, available from the RENAULT TRUCKS Spare Parts Department:

- grey 2-way connector ref. N° 50 10 293 074
- contact (0.9 to 3.1 mm²) ref. N° 50 10 347 347
- contact (2.9 to 6 mm²) ref. N° 77 01 997 034
- contact (5.9 to 10 mm²) ref. N° 77 01 997 035

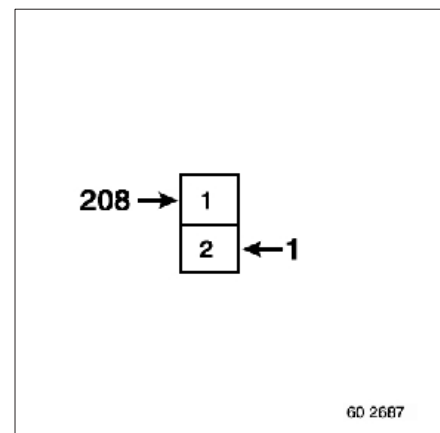

Location 8:

C971 – available power supplies (after ignition)

Parts to be used, available from the RENAULT TRUCKS Spare Parts Department:

- black 2-way connector ref. N° 50 10 293 073
- contact (0.9 to 3.1 mm²) ref. N° 50 10 347 347
- contact (2.9 to 6 mm²) ref. N° 77 01 997 034
- contact (5.9 to 10 mm²) ref. N° 77 01 997 035

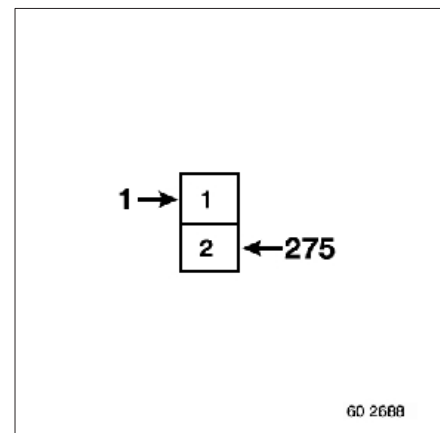

Location 9:

C914 – available power supplies

Parts to be used, available from the RENAULT TRUCKS Spare Parts Department:

- white 25-way JPT clip-holder ref. N° 50 10 214 712
- clips:
- wire section 0.6 to 1 mm² ref. N° 50 10 214 345
- wire section 1 to 1.2 mm² ref. N° 50 10 214 346

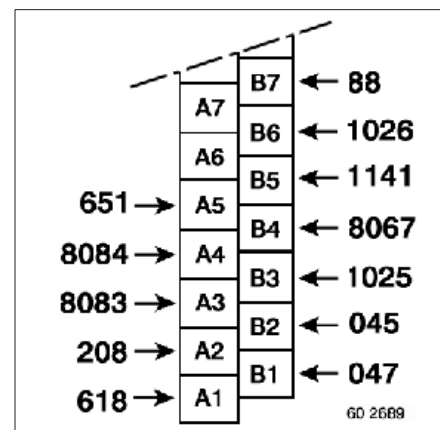

4.2 Electrical pre-arrangements

In cab on dashboard

- Two switches with built-in warning light:
 - (1): vehicle interior lighting,
 - (2): equipment power supply, machine unlocking.

In the cab on the display

- Two pictograms integrated in the instrument panel are dedicated to the bodybuilder function:
 - pictogram (3): tail lift in working position (coupled to stop light and tripping of buzzer if the road speed is above 5 km/h),
 - pictogram (4): chassis equipment alert (available to bodybuilder, coupled with stop light).

Display of pictograms:

pictogram (3) wire 651 on white connector on stand-by on bulkhead grommet, is displayed when corresponding wire is connected to earth.

pictogram (4) wire 8084 on white connector on stand-by on bulkhead grommet, is displayed when corresponding wire is connected to 24V "+".

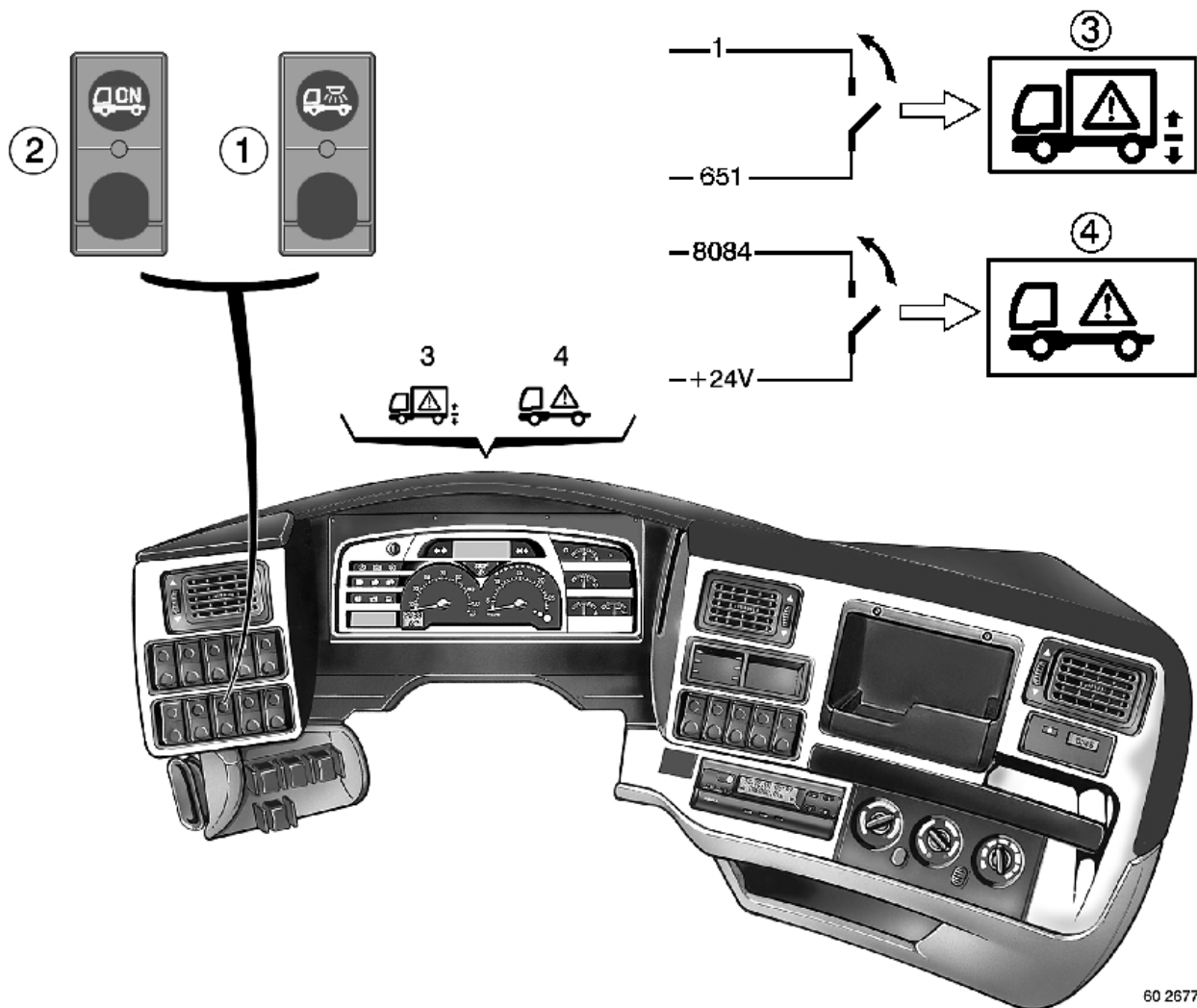

60 2677A

Electrical diagram for standard available power supplies

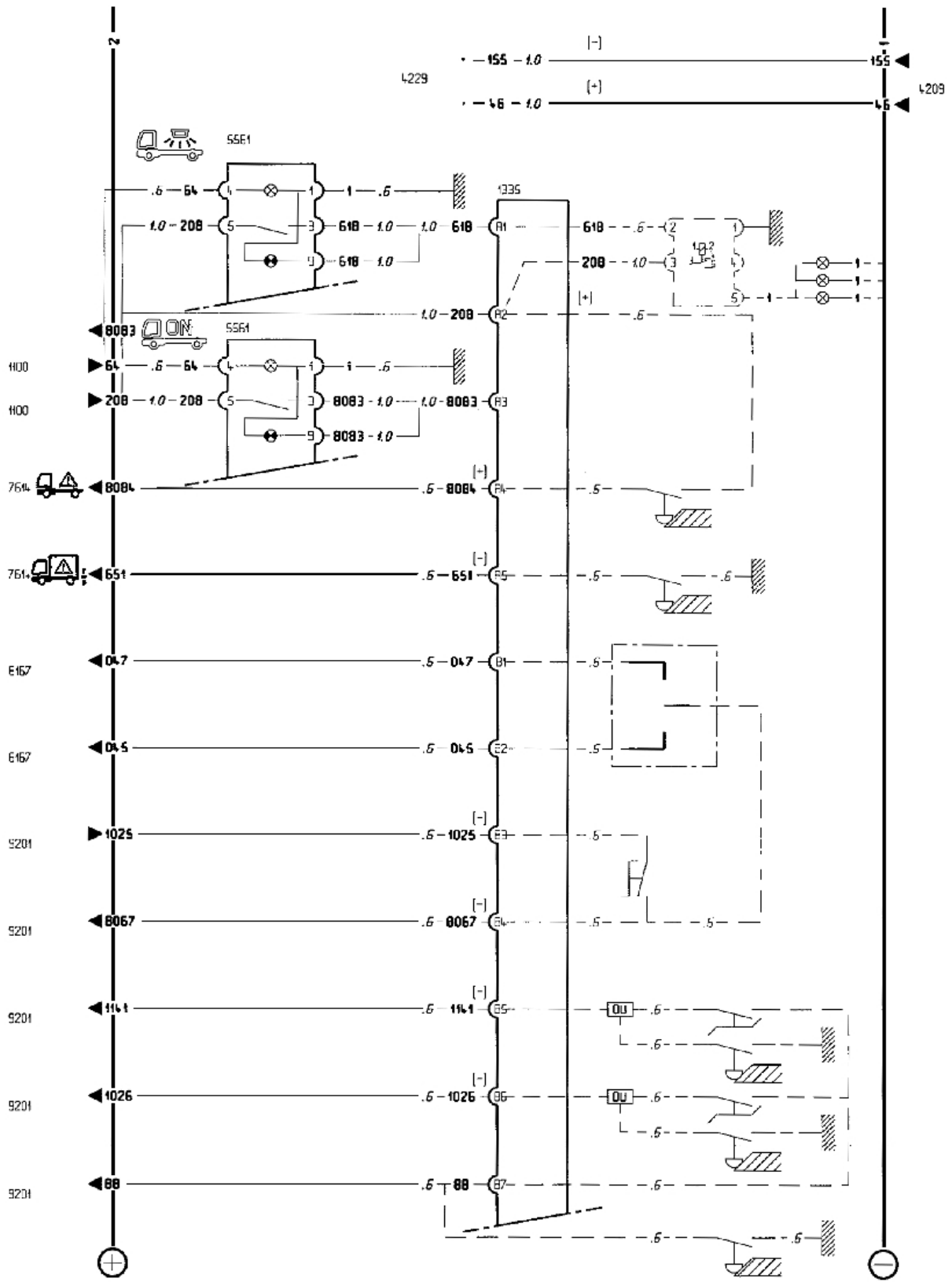

60 2678

Electrical diagram for standard available power supplies

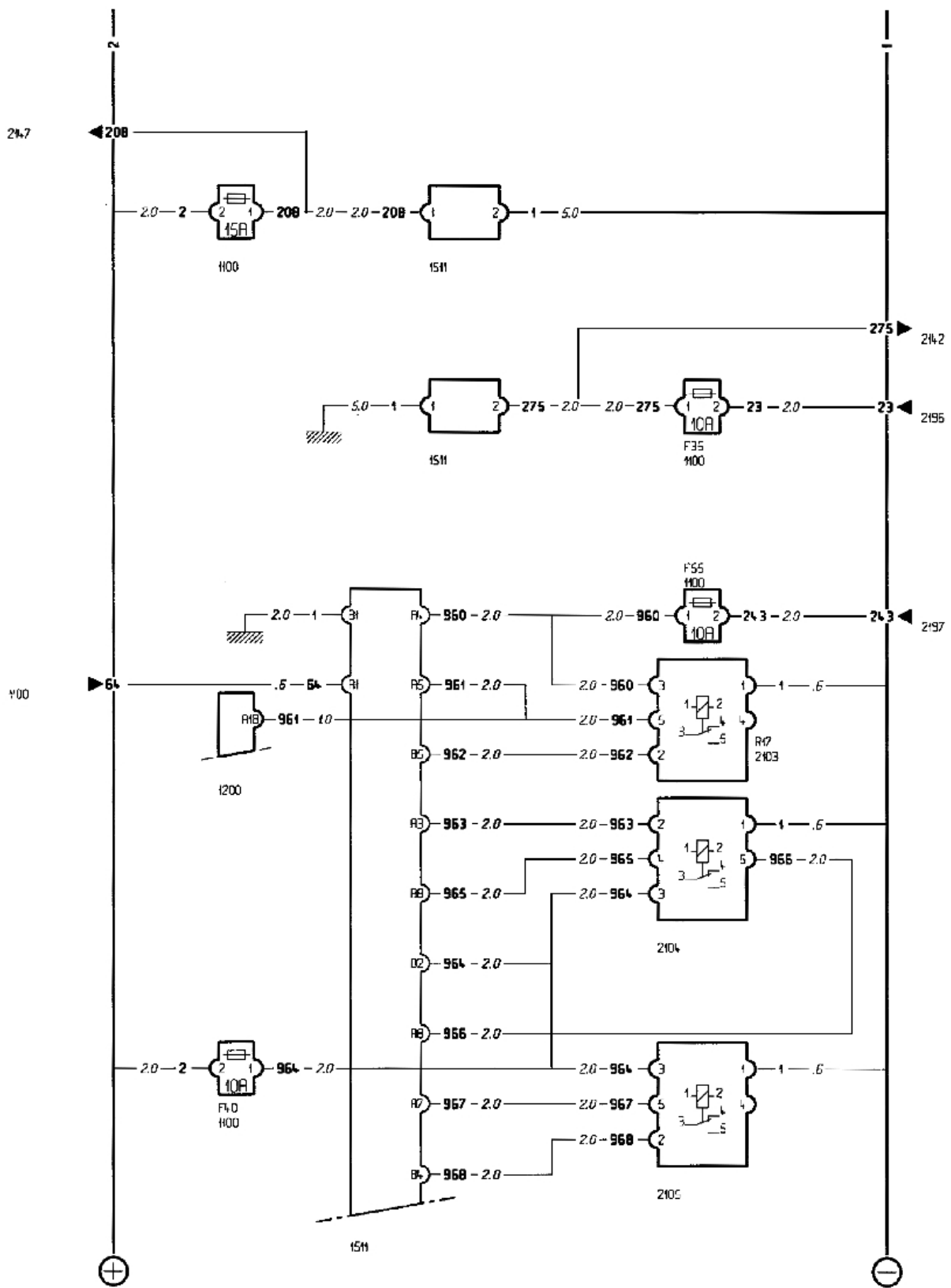

602679A

Electrical diagram for standard available power supplies

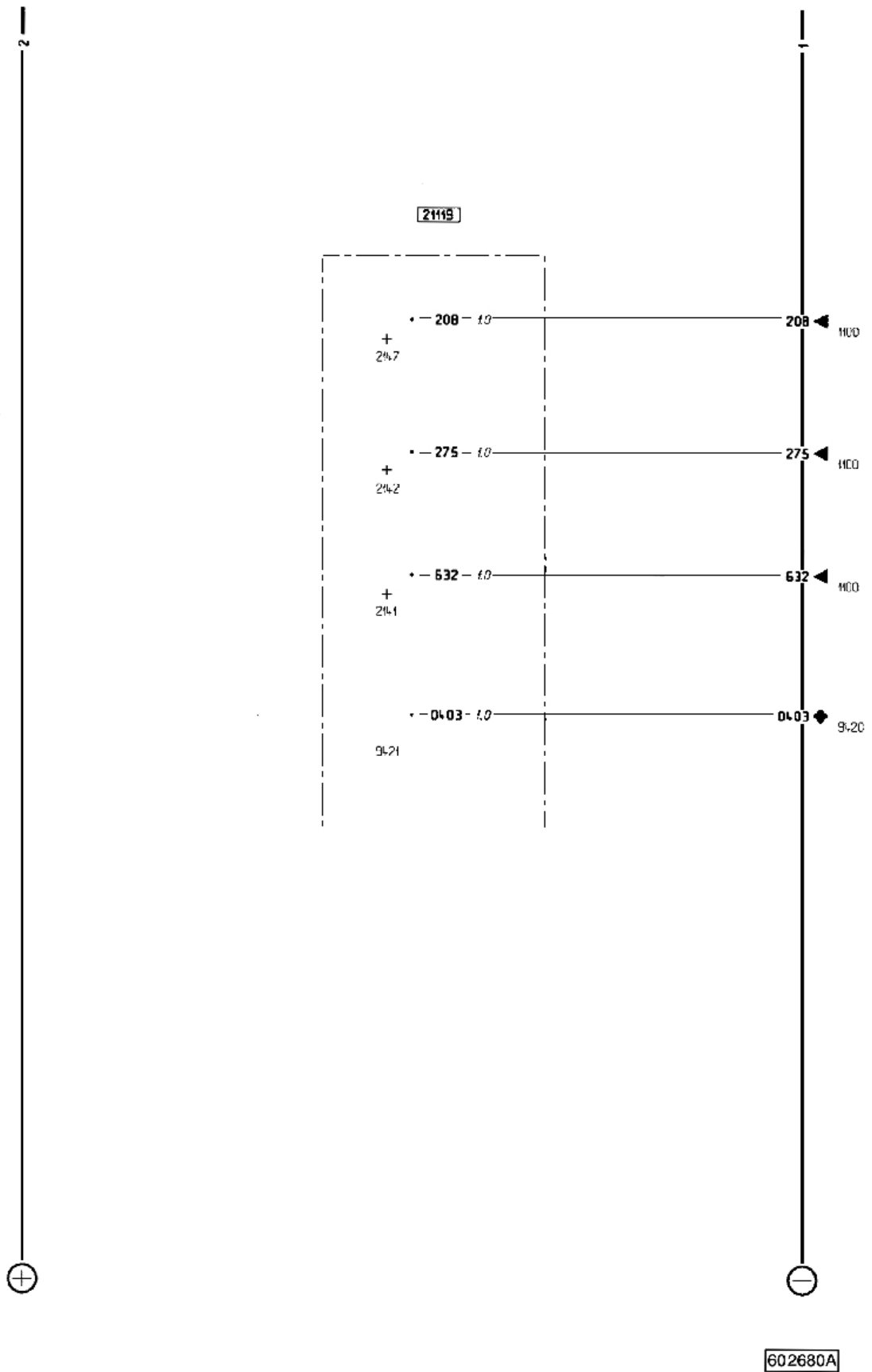

Key

1100 Fuse
1200 Fuses / relays connection unit "BFR"
1335 Available power supplies connector
1511 Fuse box
2103 Available relay N° 1 (R 17)
2104 Available relay N° 2 (R 47)
2105 Available relay N° 3 (R 48)
2141 Available power supply (lighting)
2142 Available power supply (after ignition)
2147 Available power supply (after master switch)
2196 After ignition power supply relay N° 1
2197 After ignition power supply relay N° 2
4209 Voltage dropper (telecommunications)
4229 Telephone
5561 Valves lighting control
6167 Steering wheel fingertip controls

- steering lock,
- side/parking lights,
- main beam / dipped beam headlights,
- fog driving lights / fog lights,
- horn / direction indicator,
- windscreen wiper / screen wash / headlamps wash
- cruise control

7614 Principal display
9201 Vehicle electronic control unit "VECU"
9420 Anti-theft alarm ECU
9421 Rigid perimetric protection module
21119 Available power supply (chassis)

Assignment of fuses concerning electrical pre-arrangements

Fuse	Amperage	Wire N°	Feature
F5	10	632	Available power supply (lighting)
F35	10	275	Available power supply (after ignition)
F21	15	208	Available power supply (after master switch)
F55	10	960	Available power supply (after ignition)
F40	10	964	Available power supply (available relay)

4.2 Fuses and relays connection unit "BFR"

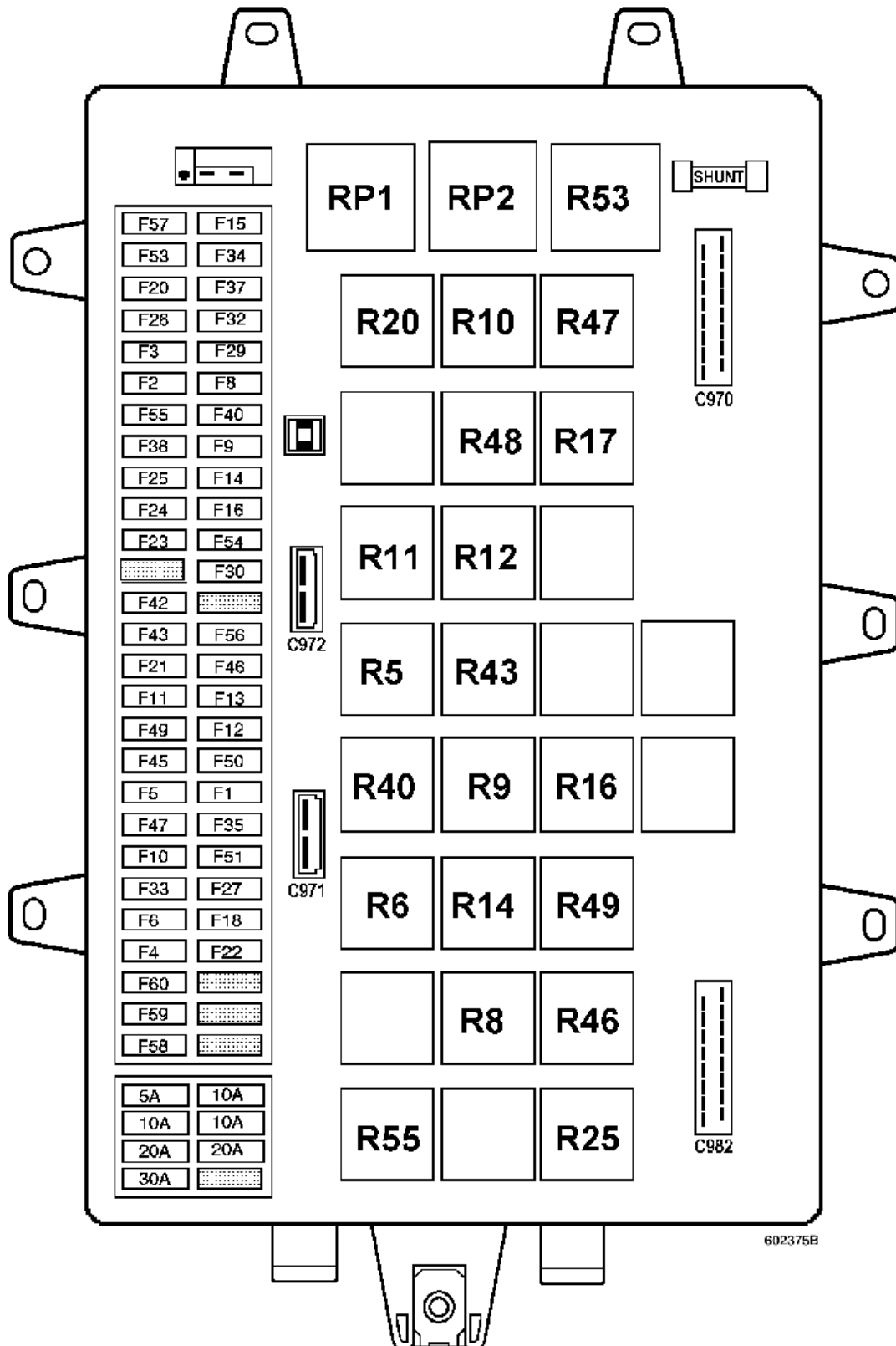

4.3 Management of engine speed

There are 2 ways of operating accessing the fast idling mode :

- by the steering wheel fingertip control,
- by the variable speed controls.

4.4 Power take-off wiring

4.4.1 Vehicle fitted with one PTO

A) Determining the rotating speed

When the vehicle is equipped with a power take-off, engagement of the PTO causes earthing of wire 88 corresponding to a regulation speed.

Engagement of PTO = earthing of wire 88

For other regulation speeds, it is necessary to connect wires 1026 and/or 1141 to earth.

Engagement of PTO alone (wire 88 earthed) =
Regulation at 1st regulation speed,
PTO A speed of RENAULT TRUCKS diagnostics tool (DIAGNOSTICA)
OR
Engagement of PTO and wires 88 and/or 1026 and/or 1141 earthed =
Regulation at 2nd, 3rd or 4th regulation speed

Note :

Wires 1026 and 1141 can be connected to earth from the chassis pre-arrangement.
Engagement of the PTO can be simulated by earthing wire 88.

B) Using the chassis-mounted fast idling variable speed control

Variable chassis-mounted speed control (example of connection)

- Install a single-function switch **(1)** between wires 1025 and 045.
- Install a single-function switch **(2)** between wires 1025 and 047.

When switch **(1)** is closed, the engine speed increases.

When switch **(2)** is closed, the engine speed decreases.

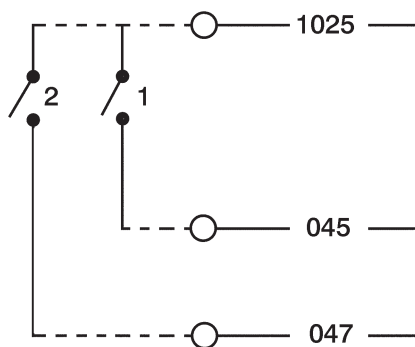

60 2194A

It is possible to install a single-function 3-position switch to avoid having to use the two acceleration and deceleration controls at the same time.

Upon the first pulse on one of the two controls, the engine passes to the pre-programmed speed, then the engine speed is adjusted by means of the controls.

IMPORTANT

All the chassis-mounted controls are doubled up on the steering wheel fingertip controls.

C) Controlling speed regulation without cruise control (e.g. demand for fast idling)

The earthing of wire 8067 is used either as demand for compacting for refuse collectors or as demand for engagement of PTO A for vehicles equipped with ASTRONIC gearbox and allows regulation of the rotating speed from the chassis.

This thus replaces moving the steering wheel fingertip control ring to the ON position.

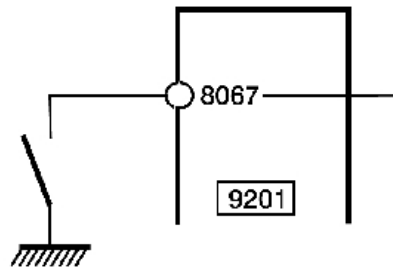

60 2623A

4.4.2 Vehicle fitted with two PTOs

A) Determining the rotating speed

When the vehicle is provided with two PTOs, engagement of the 1st PTO causes earthing of wire 88 corresponding to a regulation speed and engagement of the 2nd PTO causes earthing of wire 1026 corresponding to a different regulation speed.

Engagement of PTO A = earthing of wire 88

Engagement of PTO B = earthing of wire 1026

If both PTOs are engaged at the same time (and therefore if wires 88 and 1026 are earthed at the same time), regulation will be made at the lowest regulation speed.

Earthing of wire 88 = Regulation of PTO A at two regulation speeds
of RENAULT TRUCKS diagnostics tool (DIAGNOSTICA)

OR

Earthing of wire 1026 = Regulation of PTO B at two regulation speeds
of RENAULT TRUCKS diagnostics tool (DIAGNOSTICA)

OR

Two PTOs engaged =
Regulation at lowest regulation speeds
of RENAULT TRUCKS diagnostics tool (DIAGNOSTICA)
(as a function of the combination of the earthing of wires 88 and/or 1026 and/or 1141)

B) Using the chassis-mounted fast idling variable speed control

(See chapter 4.4.1 – B).

C) Controlling speed regulation without cruise control

(See chapter 4.4.1 – C).

4.4.3 Vehicle fitted with three PTOs

A) Determining the rotating speed

When the vehicle is provided with three PTOs, engagement of the 1st PTO causes earthing of wire 88 corresponding to a regulation speed and engagement of the 2nd PTO causes earthing of wire 1026 corresponding to a different regulation speed and engagement of the 3rd PTO causes earthing of wire 1141.

Engagement of PTO A = earthing of wire 88

Engagement of PTO B = earthing of wire 1026

Engagement of PTO C = earthing of wire 1141

If the three PTOs are engaged at the same time (and therefore if wires 88, 1026 and 1141 are earthed at the same time), regulation will be made at the lowest regulation speed.

Earthing of wire 88 = Regulation of PTO A at regulation speed
of RENAULT TRUCKS diagnostics tool (DIAGNOSTICA)

OR

Earthing of wire 1026 = Regulation of PTO B at regulation speed
of RENAULT TRUCKS diagnostics tool (DIAGNOSTICA)

OR

Earthing of wire 1141 = Regulation of PTO C at regulation speed
of RENAULT TRUCKS diagnostics tool (DIAGNOSTICA)

Two or three PTOs engaged =
Regulation at lowest regulation speeds
of RENAULT TRUCKS diagnostics tool (DIAGNOSTICA)
(as a function of the combination of the earthing of wires 88 and/or 1026 and/or 1141)

B) Using the chassis-mounted fast idling variable speed control

(See chapter 4.4.1 – B).

C) Controlling speed regulation without cruise control

(See chapter 4.4.1 – C).

4.4.4 Vehicle fitted with one engine rear PTO or no PTOs at all

In this case, it is the bodybuilder who will earth wires 88 and/or 1026 and/or 1141 according to the situation.

A) Determining the rotating speed

When the vehicle is not provided with any PTO, to declare the desired regulation speed, it is necessary to earth the corresponding wires 88, 1026 and/or 1141, where each combination corresponds to a different regulation speed.

1, 2 or 3 wires earthed (wires 88 and/or 1026 and/or 1141) =
Combination corresponding to one regulation speed

Note :

These wires can be earthed from the chassis pre-arrangement.

IMPORTANT

For modification to the regulation speeds, it is necessary to consult your RENAULT TRUCKS dealer, who will change the settings using the diagnostics tool (Diagnostica).

4.5 Use of the steering wheel fast idling fingertip control

Move the ring (1) to the "ON" position (except refuse collectors).

To vary the idling speed, turn the ring (2) to bring "R+" or "S-" opposite the mark (3), then release it.

Depress the accelerator pedal to bring the engine to the required engine speed and in this position, turn the ring (2) to bring "S-" opposite the mark (3) so as to memorize the speed, then release it.

Release the accelerator pedal.

To fine tune the engine speed :

- Turn ring (2) to bring "R+" opposite the mark (3) to increase the speed.
- Turn ring (2) to bring "S-" opposite the mark (3) to reduce the speed.

Any action on the brake pedal or any gearshifting or moving the ring (1) to the "OFF" position overrides the feature.

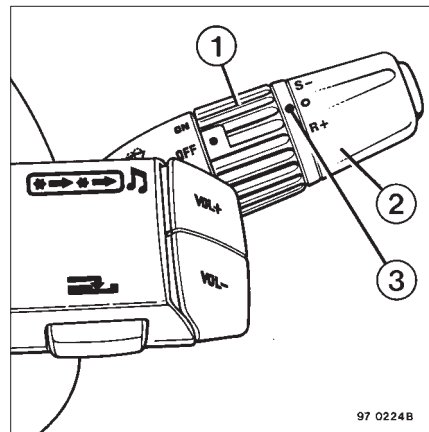

4.5.1 Vehicle fitted with a power take-off

When the PTO is in operation, move the ring (1) to the "ON" position. The first action on the ring (2) ("S-" or "R+") calls up the works set engine rotating speed (1200 rpm) (or 950 rpm for vehicles equipped with a second PTO).

Rotating speed

In the event of hydraulic pump drive, do not exceed the rotating speed indicated by the equipment manufacturer.

The engine speed is limited to 1500 rpm by the works setting.

Depending on the equipment fitted by the equipment manufacturer, this engine speed can be modified by means of the RENAULT TRUCKS test tool.

IMPORTANT

Avoid actuating the accelerator pedal during the use of the fast idling feature.

4.6 Engine speed information

It is possible to retrieve engine speed information by connecting up to terminal W (**A**) of the alternator.

- Drive ratio of engine with capacity higher than 6 litres: 3.2
- Drive ratio of engine with capacity 4 to 6 litres: 2.71

Lugs used on terminal W:

The nut type lug is recommended for ease of use and quality (resistance to fatigue and vibration).

- Nut lug M4 : 5010 306 473, 5010 480 479, 5010 306 616
- Nut lug M5 : 5010 306 474, 5010 306 617
- Nut lug M6 : 5010 306 579, 5010 480 495

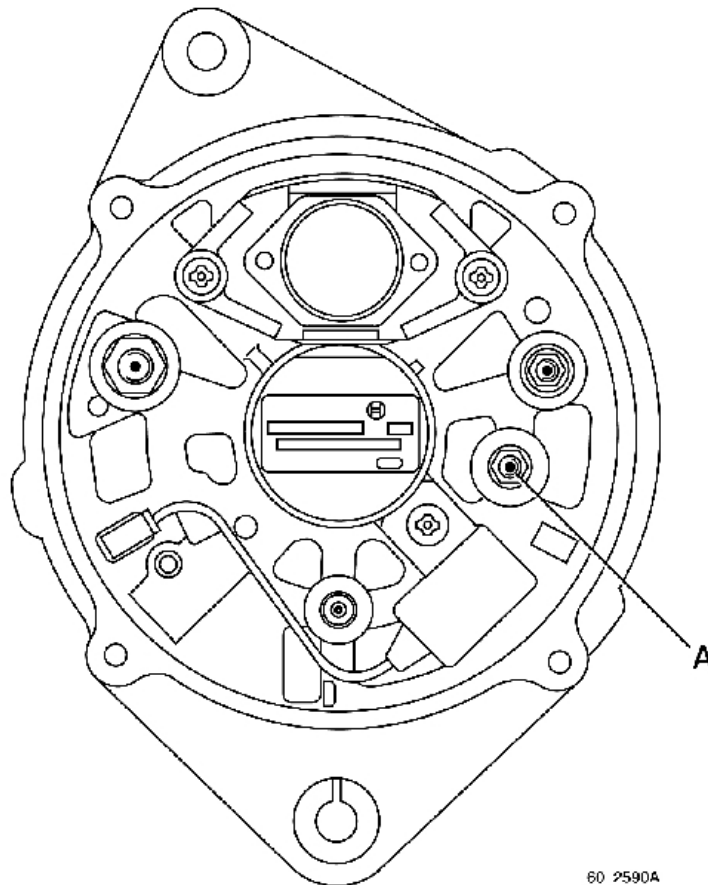

60 2590A

4.3 Trailer sockets

2113 - 7-pin trailer socket type "24 N"

Terminal	Assignment	Fuse	Amp
1	Earth	-	-
2	Trailer LH parking lamps	F4	10A
3	Trailer LH flashing lamps	F45	20A
4	Trailer stop lamps	F27	10A
5	Trailer RH flashing lamps	F45	20A
6	Trailer RH parking lamps	F4	10A
7	Available	-	-

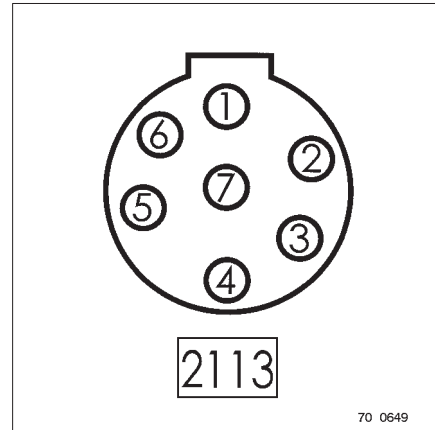

2100 - 15-pin trailer socket

Terminal	Assignment	Fuse	Amp
1	Trailer LH flashing lamps	F45	20A
2	Trailer RH flashing lamps	F45	20A
3	Trailer fog lamps	F8	10A.
4	Earth	-	-
5	Trailer LH parking lamps	F4	10A
6	Trailer RH parking lamps	F4	10A
7	Trailer stop lamps	F27	10A
8	Trailer reversing lamps	F16	10A
9	Trailer working spotlamps	F43	10A
10/15	Available	-	-

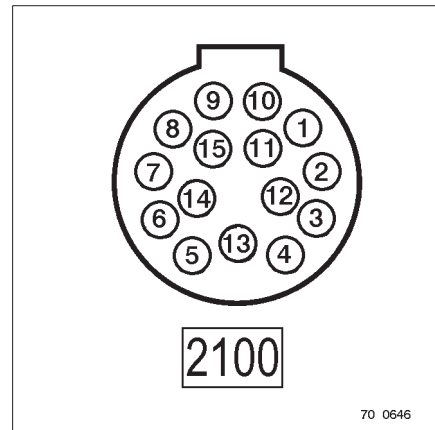

2115 - 7-pin trailer socket type "24 S"

Terminal	Assignment	Fuse	Amp
1	Earth	-	-
2	Perimetric protection module	-	-
3	Trailer reversing lamps	F16	10A
4	Trailer working spotlamps	F43	10A
5	Trailer "EBS" safety warning lamp	-	-
6	Trailer + 24V power supply	F1	10A
7	Trailer fog lamps	F8	10A

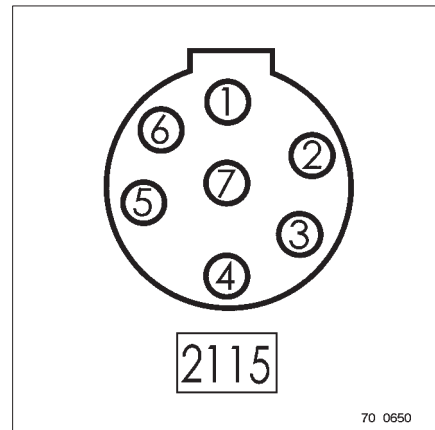

2116 - 7-pin trailer socket type "EBS"

Terminal	Assignment	Fuse	Amp
1	Power supply (after master switch)	F56	20A
2	Power supply (after ignition)	F1	10A
3	Earth	-	-
4	Earth	-	-
5	Trailer "EBS" safety warning lamp	-	-
6	"EBS" ECU	-	-
7	"EBS" ECU	-	-

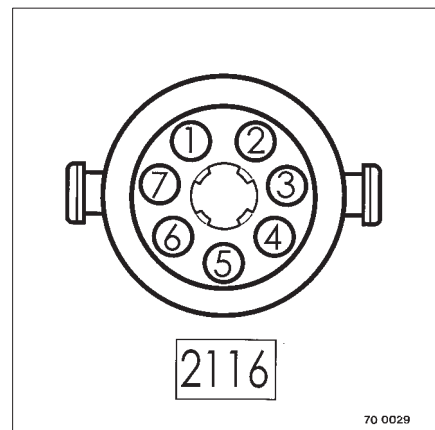

4.8 ADR regulation for vehicles equipped with independent (add-on) heating

In the case of installation of an auxiliary pump on the vehicle, use the pre-arrangement available on the violet connector (A) attached to the add-on heating bracket located under the bottom bunk.

Wire section 2 mm².

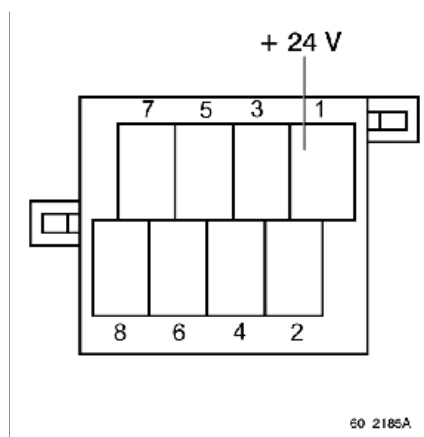
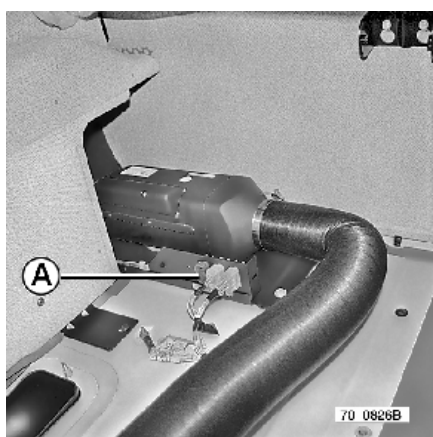

60 2185A

5. LATERAL LIGHTS PRE-ARRANGEMENT

It is possible to install equipment lateral signalling lamps without having to convert the vehicle installation. The lateral signalling lights wiring harness is on stand-by on the right-hand sidemember.

Available on chassis:

- One connector (1) on the RH sidemember, in front of the necking.
- The other connectors (2) are distributed along the RH sidemember.
- 2 lateral lights (5) are located on the extremities of the rear lights (rear line wiring harness).

Available in cab:

- Three long extensions (3) with lateral lights for equipment LH side.
- Three short extensions (4) with lateral lights for equipment RH side.
- Fastenings.

Comply with the regulations in force for positioning the lateral lights. The wiring harnesses for the lateral lights must be fastened and protected against heat radiation (electric retarder and exhaust in particular).

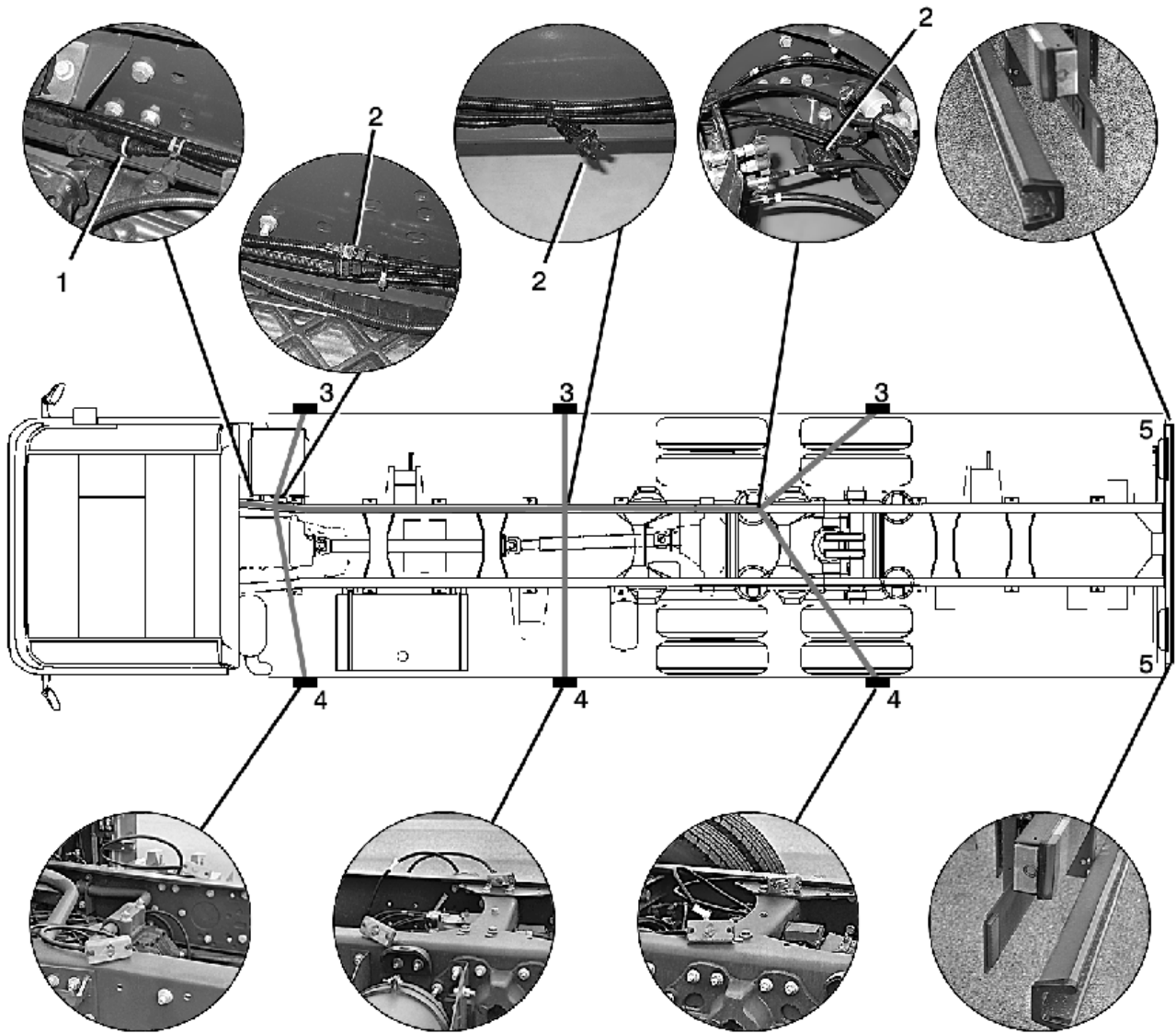

60 2881A

Electrical diagram for lateral lights

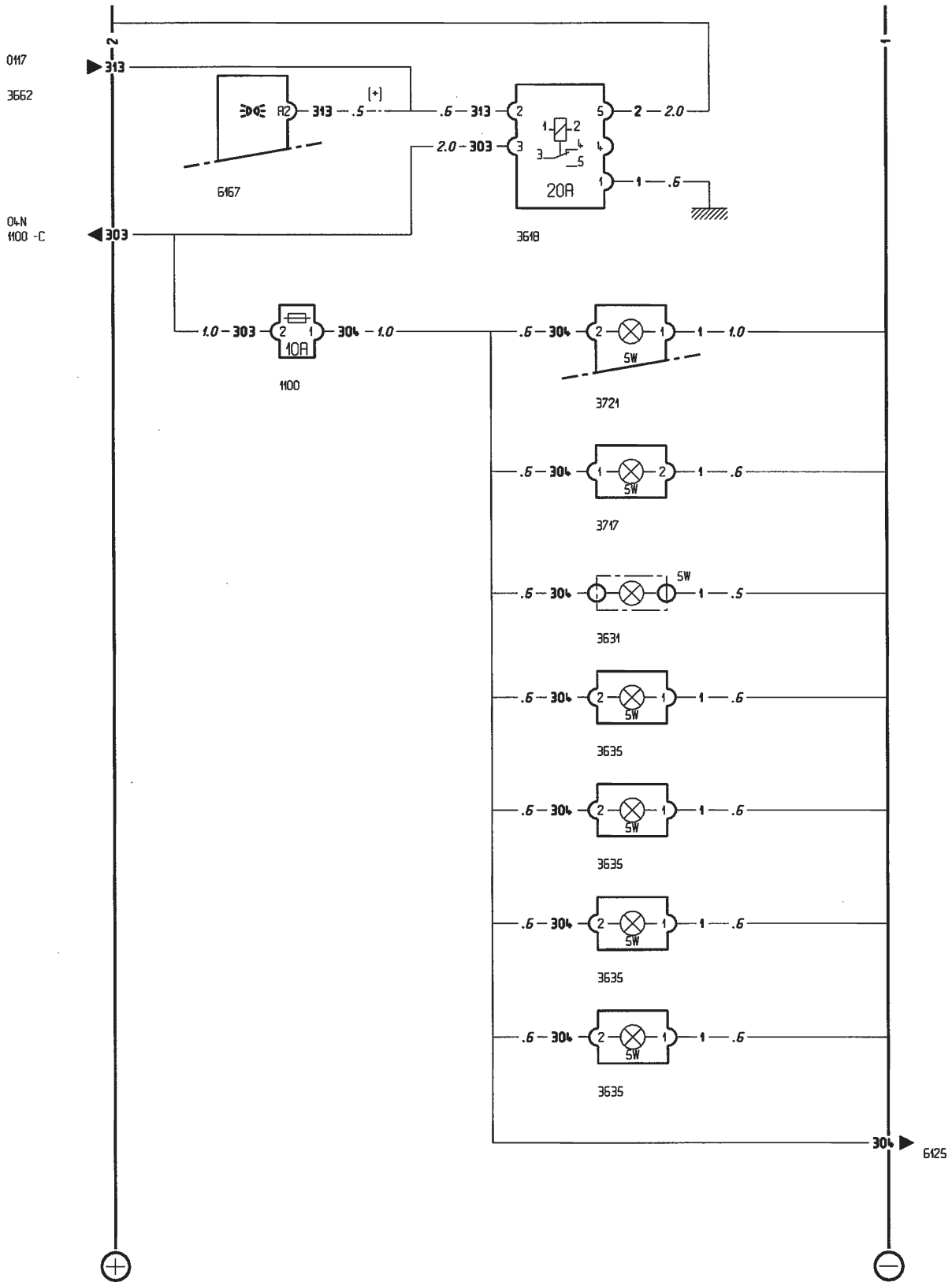

60 2690

Electrical diagram for lateral lights

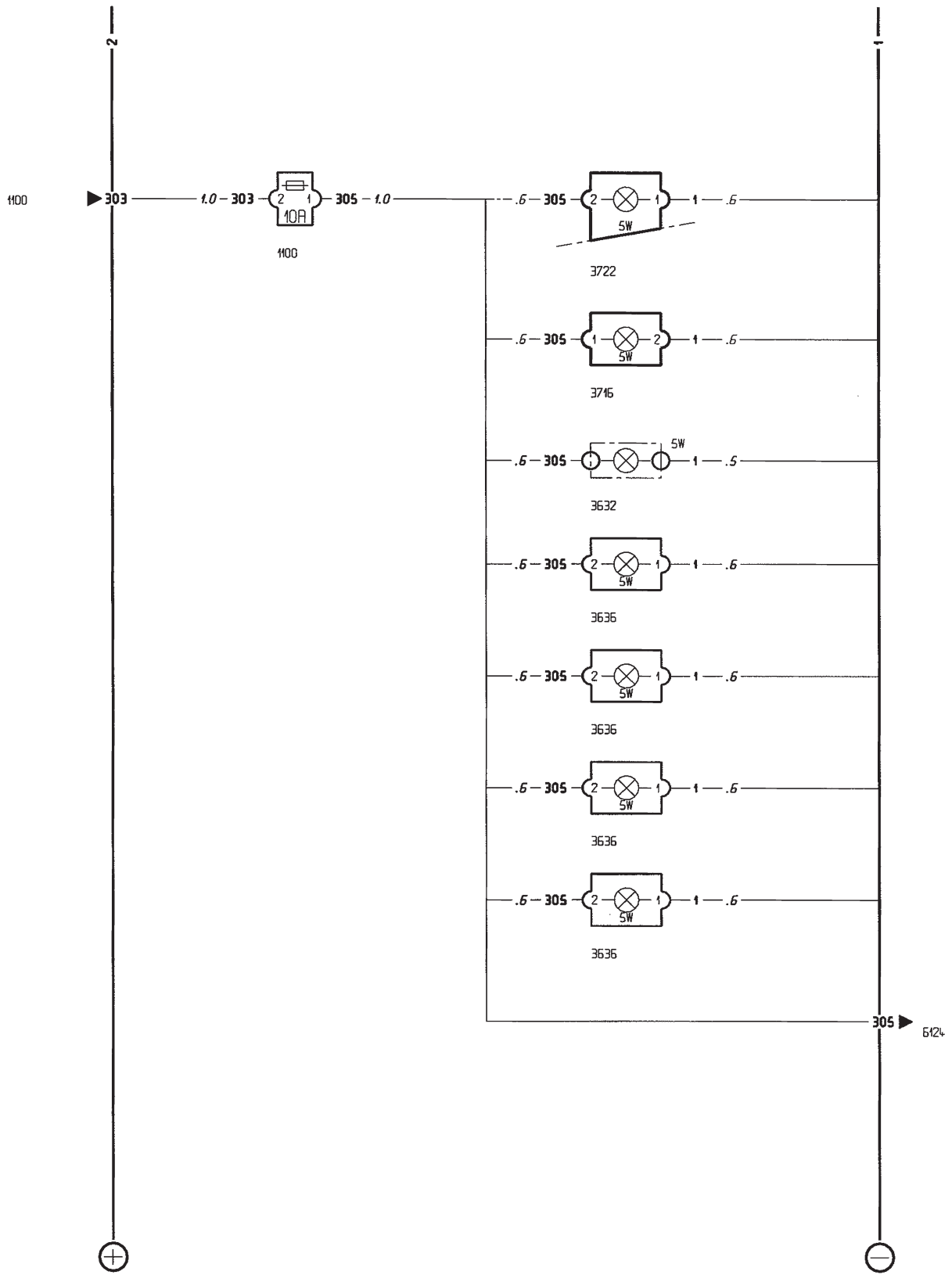

60 2691

Key

- 0117 - Protection diodes
- 1100 - Fuse
- 3618 - Side/parking lights relay
- 3631 - RH side marker lamp
- 3632 - LH side marker lamp
- 3635 - RH marker lights (bodybuilder equipment)
- 3636 - LH marker lights (bodybuilder equipment)
- 3662 - Lighting relay
- 3716 - LH central marker lamp
- 3717 - RH central marker lamp
- 3721 - RH rear lights
 - flashing
 - stop
 - fog
 - reversing
 - side/parking
- 3722 - LH rear lights
 - flashing
 - stop
 - fog
 - reversing
 - side/parking
- 6124 - LH main beam / dipped beam headlamp + side/parking lamp
- 6125 - RH main beam / dipped beam headlamp + side/parking lamp
- 6167 - Steering column fingertip controls
 - anti-theft
 - side/parking lights
 - main/dipped beam headlights
 - fog driving lamps / fog lamps
 - horn / direction indicator
 - windscreen wiper / screen wash / headlamp wash
 - cruise control

Assignment of fuses

Fuse	Amperage	Wire N°	Feature
F2	10	304	RH marker light (bodybuilder equipment)
F3	10	305	LH marker light (bodybuilder equipment)

**CHAPTER -C-
SUPPLEMENTARY INFORMATION
ON THE “RENAULT MAGNUM E-TECH” VEHICLE**

1. MOUNTING OF POWER TAKE-OFFS

To install an auxiliary belt drive pulley, two layouts are possible:

- on gearbox-mounted PTO,
- on engine flywheel-mounted PTO.

1.1 Gearbox-mounted PTO

Table of possible gearbox-mounted PTO assemblies

Power take-off		Gearbox		
ZF	HYDROCAR	ZF 16S181 OD	ZF 16S181 DD	ZF 16S221 DD
NH 1B/C	S81Z1 B/C	X	X	X
NH 4B/C	S84Z1 B/C	X	X	X
N221-10 B/C				X

NOTE

The letter “B” or “C” added after the PTO type indicates the type of coupling mounted on the PTO output :
 B - Flange
 C - Splined shaft.

PTO characteristics

Type		Maximum output torque (Nm)	Direction of rotation	Weight (kg) ZF/HYDROCAR	Extra quantity of oil (L) ZF/HYDROCAR
ZF	HYDROCAR				
NH 1B/C	S81Z1 B/C	1000*	opposite to engine	5-4	+0,15
NH 4B/C	S84Z1 B/C	430**	same as engine	9-8	+0,25

Maximum output torques are given for a rotating speed at the PTO input of 1500 rpm.

* Full-time use (do not exceed half the maximum torque): in case of use at full power, it is essential to equip the PTO with a lubrication kit.

** Part-time use < 30 minutes.

*** Part-time use < 30 minutes: for full-time use, provide a lubrication kit.
 Consult the RENAULT TRUCKS Product Applications Department.

Drive ratio

Low
 High

Power take-off		Gearbox		
ZF	HYDROCAR	ZF 16S181 OD	ZF 16S181 DD	ZF 16S221 DD
NH 1B/C	S81Z1 B/C	0,92 1,09	0,77 0,92	0,77 0,92
NH 4B/C	S84Z1 B/C	0,82 0,98	0,995 1.189	0,995 1.189

Type			N221/10 (25 kg)		
			Output C	Output D (additional PTO on N221/10)	
				NL/1	NL/4
Use (extra + 0.5 litre of oil)			full-time	full-time	< 30 min.
Output torque (Nm)			730	600	430
Direction of rotation			same as engine	opposite to engine	same as engine
Gearbox	Spread	Range change	PTO output ratio		
ZF 16 S 181	13,80 0,84	Low	1,35	0,91	0,91
		High	1,62	1,09	1,09
ZF 16 S 181	16,41 1,00	Low	1,14	0,77	0,77
		High	1,35	0,91	0,91
ZF 16 S 221	16,41 1,00	Low	1,14	0,77	0,77
		High	1,35	0,91	0,91

While outputs C and D are in operation, the sum of the torques should not exceed > 1000 Nm.

Maximum torque transmissible by the PTO

$$P = \frac{C \times n \times \eta}{9550}$$

P: power (kW)
C: drive torque (Nm)
n : engine rotating speed (rpm)
η : PTO drive ratio

Maximum permissible torque for use of a flanged hydraulic pump

$$C = \frac{15,92 \times Q \times p}{n \times \eta}$$

C: torque (Nm)
Q: output (l/min)
P: pressure (bar)
n : engine rotating speed (rpm)
η : efficiency

Frequency of use of PTOs

- Full-time use:

Do not exceed half the maximum torque. In case of use at full power, it is essential to fit the PTO with a lubrication kit.

- Part-time use:

The maximum operating time is 30 minutes, followed by a minimum stopping time of 30 minutes (for cooling down).

PTO control: consult the vehicle driving and servicing handbook.

The maximum rotating speed of the PTO output shaft is 3000 rpm.

For any PTO modification (output shaft, lubrication kit), contact the manufacturer's commercial network.

1.1.1 Instructions for the assembly of auxiliary hydraulic pumps to type “C” PTOs (ZF or Hydrocar)

Connection of the hydraulic pump must correspond to standard ISO 7653, type D.

Fluidtight seal between pump and PTO

The seal between the pump and the PTO must be made by two gaskets (**J1 & J2**) with an air drain (**E**) between the gaskets (**J1 & J2**).

IMPORTANT

*The air drain (**E**) allows the chamber to communicate with the outside and must guarantee that gearbox oil is not aspirated and that hydraulic oil does not penetrate inside the gearbox.*

The gaskets must be capable of withstanding temperatures reaching as high as 120°C.

The gasket (**J1**), fitted on the PTO side, must guarantee fluid-tightness of the gearbox filled with oil specified by the manufacturer.

The gasket (**J2**), fitted on the pump side, must guarantee fluidtightness of the pump containing hydraulic oil.

Correct operation of the air drain must be guaranteed at all times (do not paint it, blank it off or let it become fouled).

IMPORTANT

*In the event of oil leakage through (**E**), the entire system must be immediately checked out.*

1.2.2 Calculation of the weight torque

In the event of direct assembly of a hydraulic pump or another auxiliary belt drive pulley (2) on the PTO (1), the weight torque should not exceed the 50 Nm.

Overstepping this value may lead to fast damage to the PTO or the gearbox.

Limited to 30 Nm on: ZF N221-10

Calculation method

$$C_p = P \times d$$

C_p : weight torque (Nm)

P : pump weight (N)

d : distance separating PTO contact face from the vertical passing through the centre of gravity (**g**) of the pump.

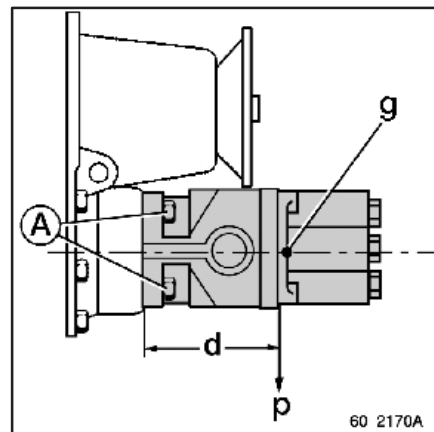
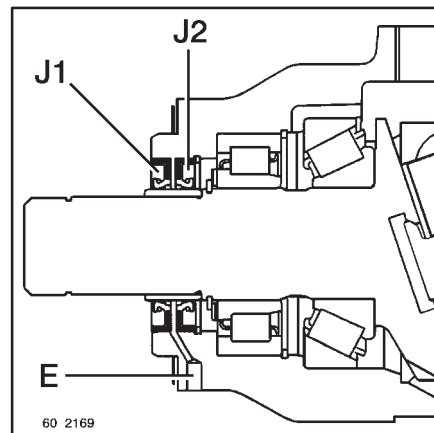

1.2.3 Fastening the hydraulic pump (A)

Apply a tightening torque of 70 Nm \pm 15% (Hydrocar), 65 Nm \pm 15% (ZF).

- Use the nuts delivered with the PTO (class 10.9).

- This torque is to be checked periodically according to a frequency to be defined by the bodybuilder.

- In exceptional situations compelling removal of the PTO, refer to the PTO manufacturer's assembly instructions.

Stud tightening torque: 20 Nm \pm 15% with Loctite 242 or 542.

IMPORTANT

The assembly of equipment to the PTO remains under the responsibility of the installer.

2. AIR-OPERATED EQUIPMENT

2.1 Connection of extra auxiliary equipment

The addition of extra equipment not provided by the manufacturer must compulsorily be connected to the auxiliary equipment circuit.

The compressed air consumption of such auxiliary equipment should under no circumstances compromise the filling times of the brake circuits laid down by the legislation in force.

Position of union for extra auxiliary equipment

The snap-on union (1) Ø 6-8 mm is located under the front LH corner of the cab. The extra piping should not place any mechanical stress on the union.

NOTE

The pipe unions on the auxiliary equipment circuit can be dismantled.

The pipe unions on the braking circuit cannot be dismantled.

The **RENAULT TRUCKS** Product Applications Department is at your disposal for any further information.

Multiple snap-on unions can be used for supplying air to extra auxiliary equipment.

The free port for such unions is neutralized by an unlockable blanking plug (made from red polyamide).

2.2 Table of compressors

Vehicle	Engine	Compressor type and displacement	Drive ratio	Output at 12.5 bars at 1000 engine rpm
RENAULT MAGNUM E-TECH	MIDR 06.24.65	Twin cylinder 500 cc	1.21	308 L. min

Location after tilting of cab

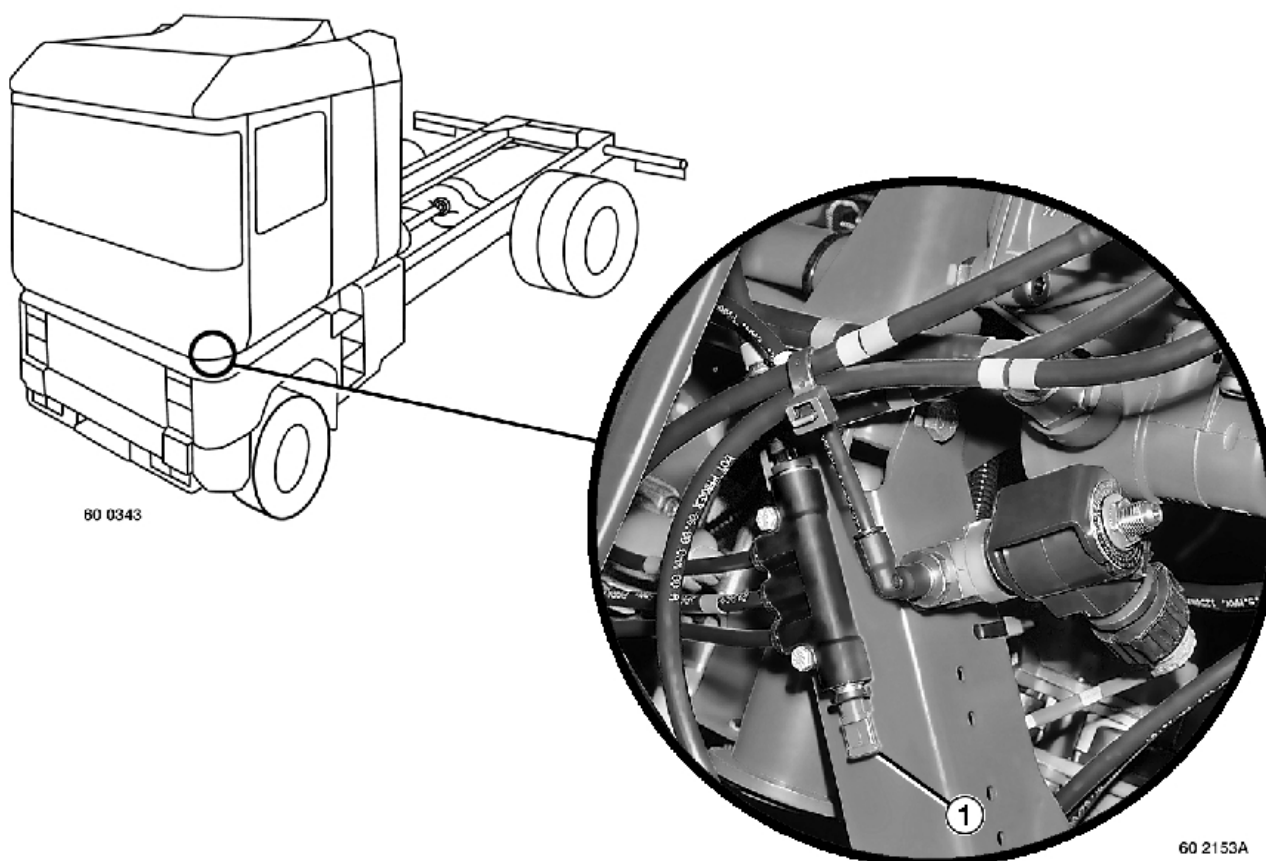

3. ELECTRICS

3.1 Cab earths

Driver's door and top side ledge earths

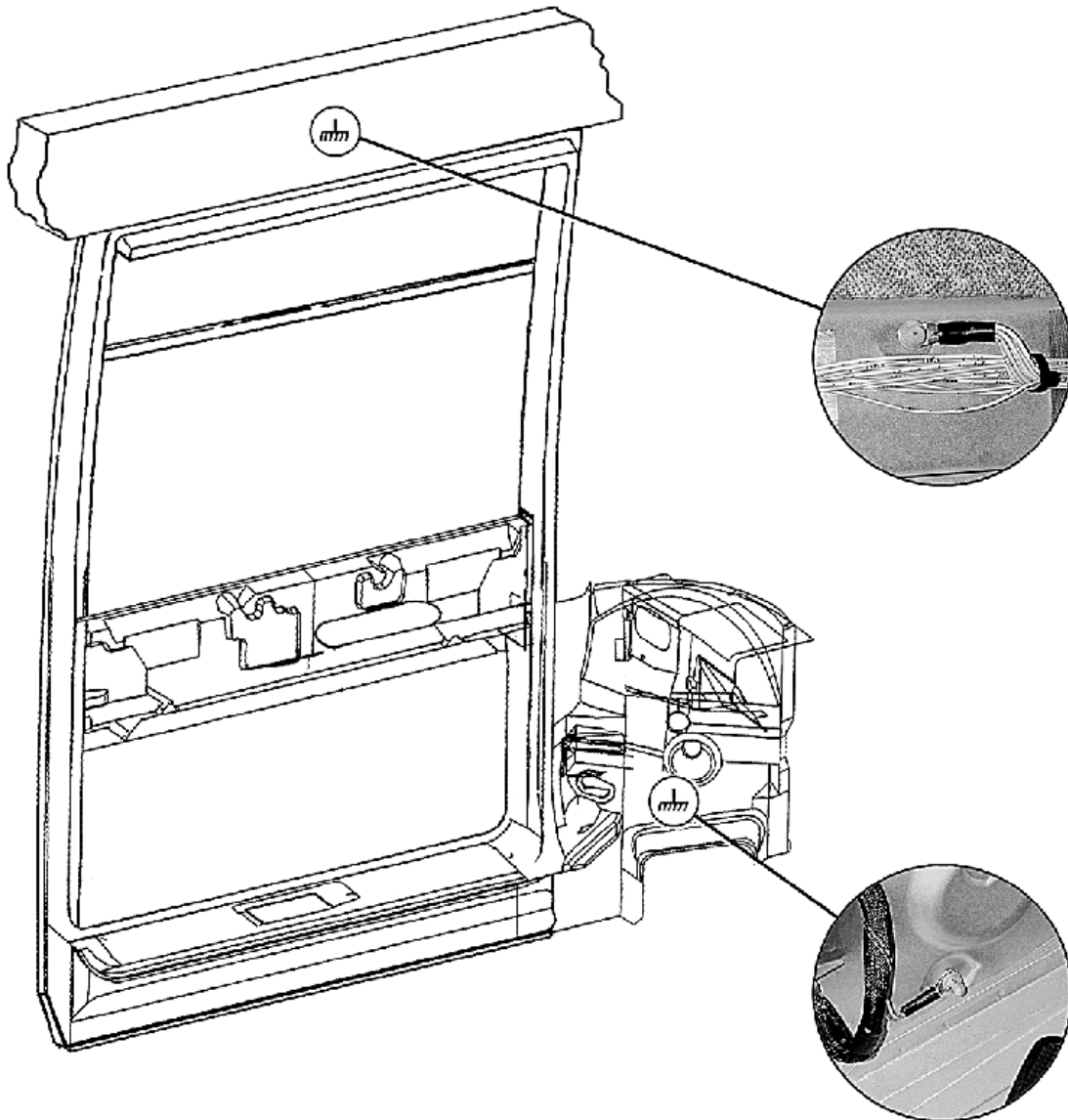

60 2165A

Passenger's door and top side ledge earths

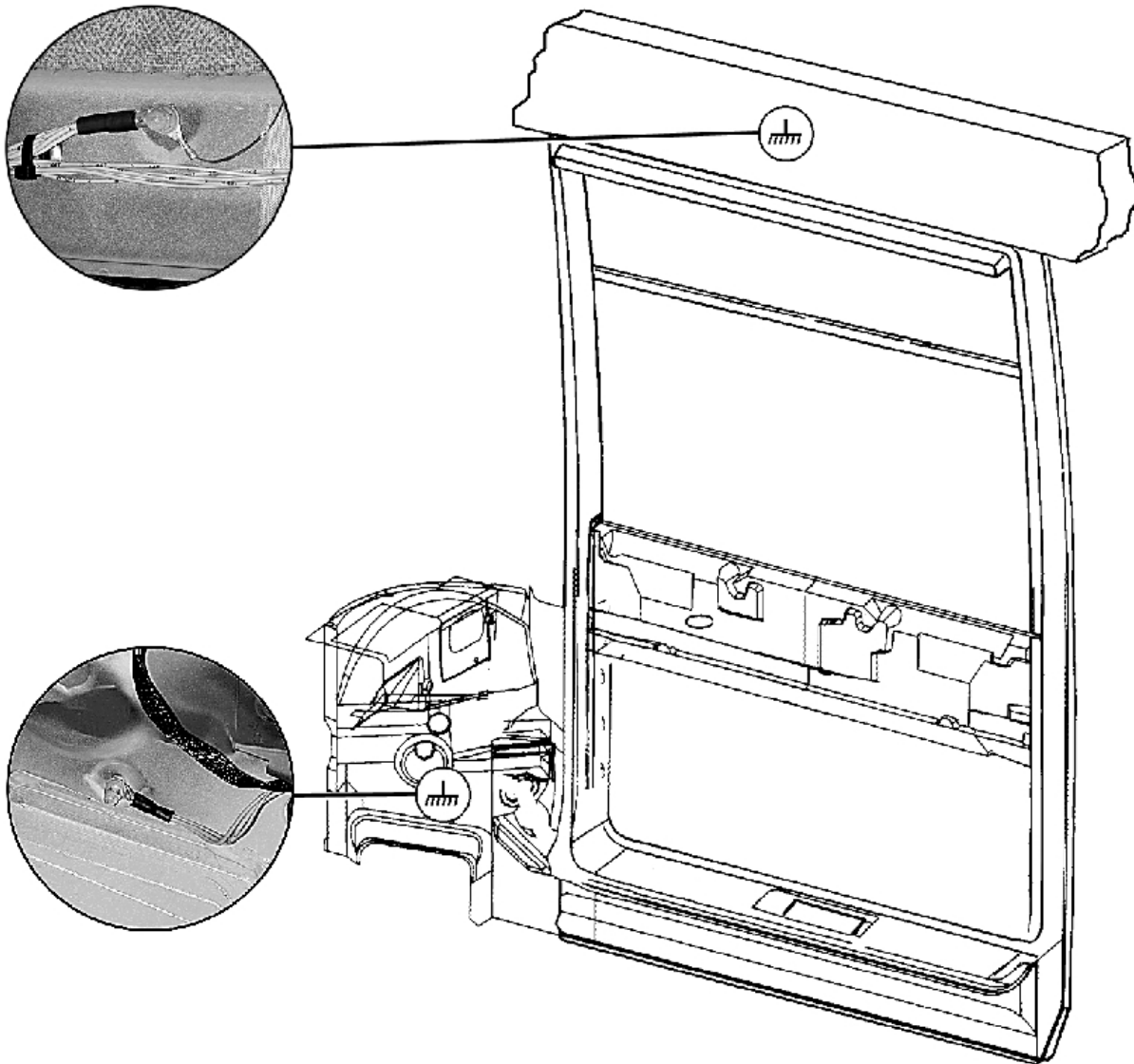

80 2166A

Cab floor earths

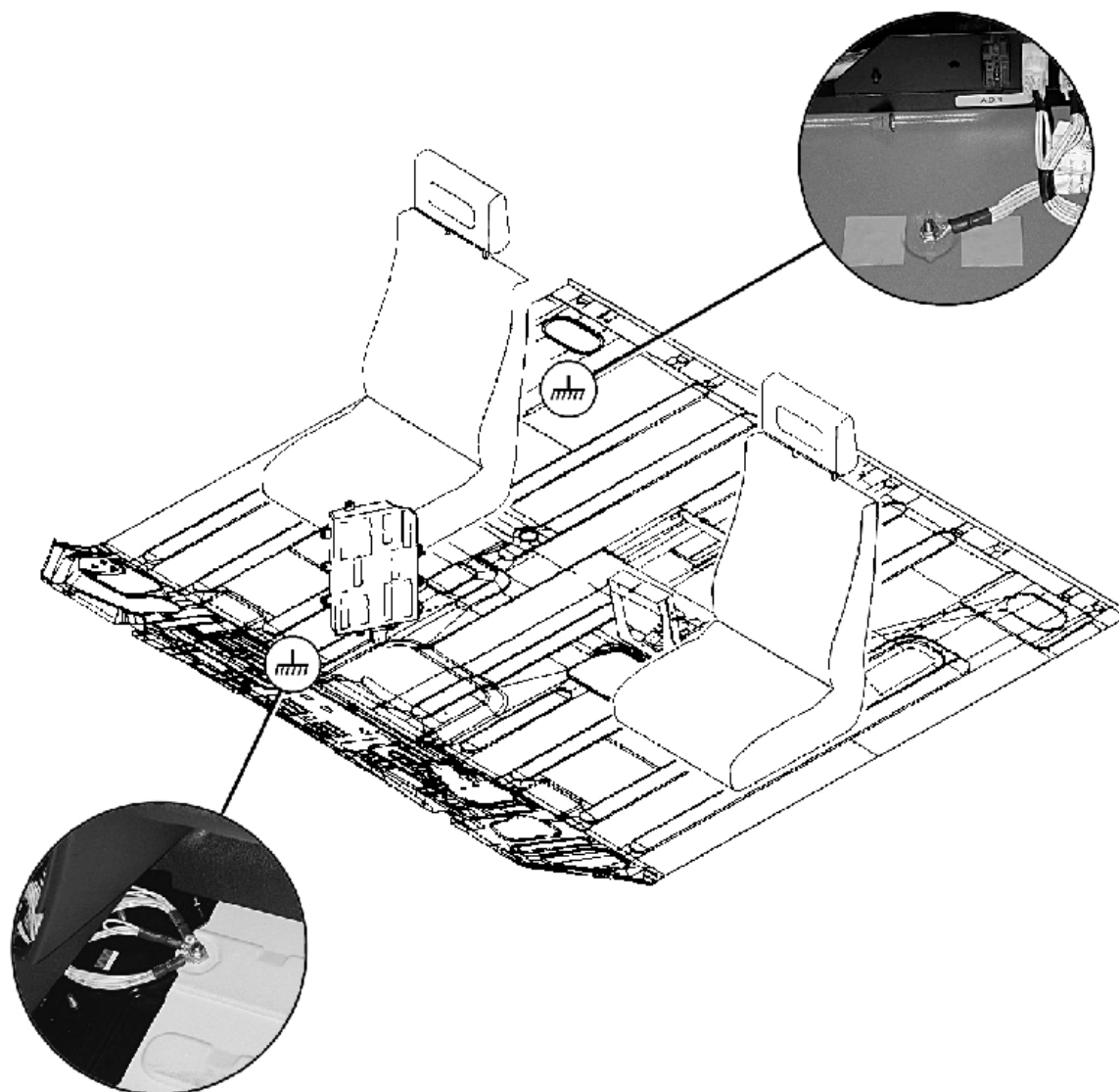

60 2167A

Cab front end earth

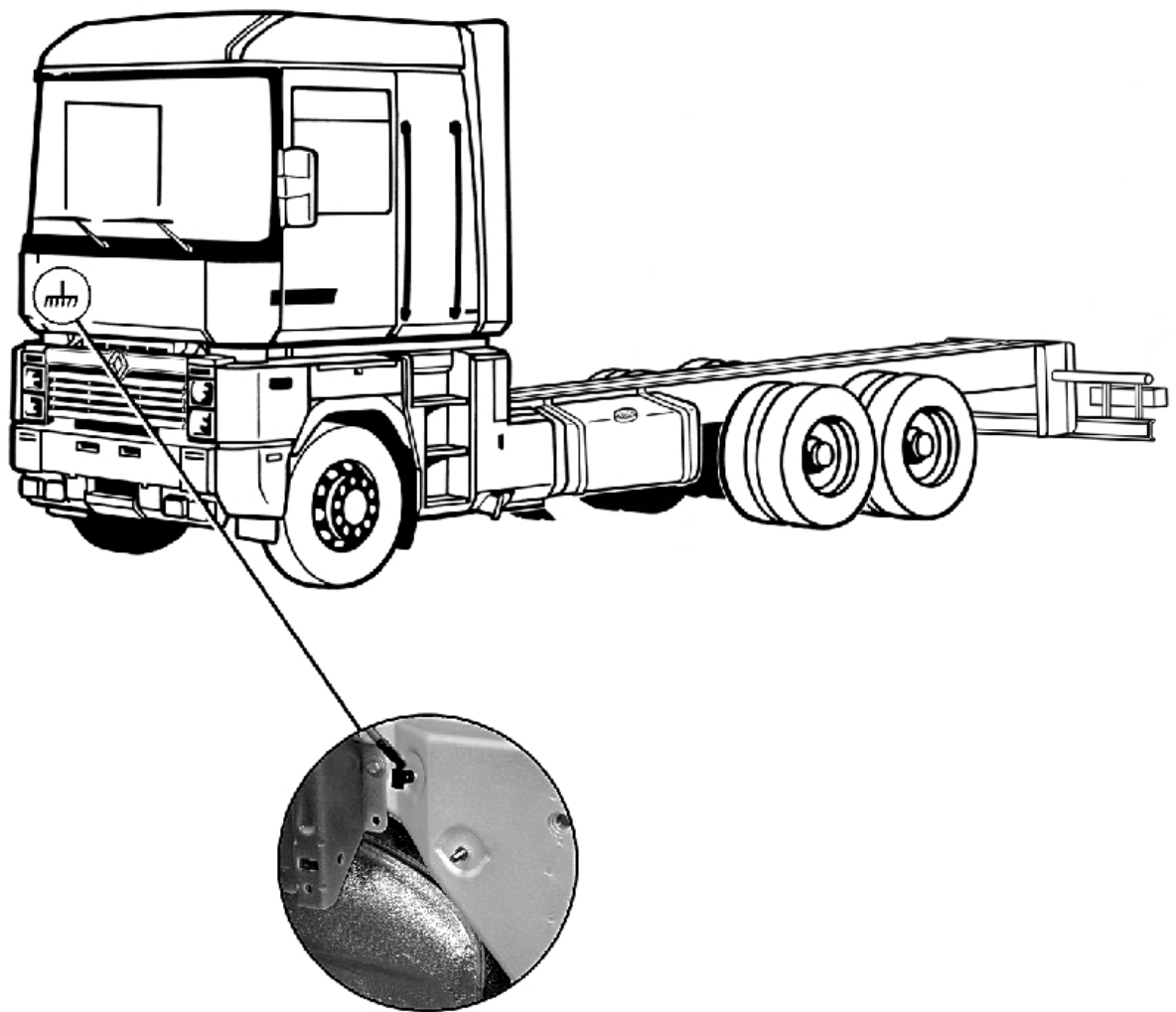

60 2168A

Fastening of earth lug or braid to cab

- 1 - Front end panel
- 2 - Stainless steel washer dia. 6 mm
- 3 - Front end M6 stainless steel stud
- 4 - M6 stainless steel nut
- 5 - Earth lug or braid

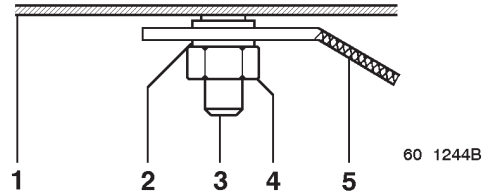

Nut (4) tightening torque: 9 ± 1 Nm

Assembly to electrical earth points diameter 11 mm

- A - Spotfaced surface dia.30 mm
- B - Plain stainless steel washer dia. 10 mm
- C - Stainless steel nut H10x150
- D - Earth lug or braid
- E - Sidemember
- F - Stainless steel screw M10x150

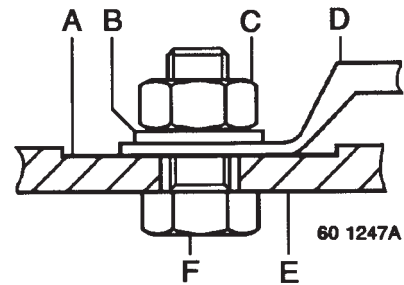

Tightening torque: 45 ± 9 Nm.

Assembly to electrical earth points diameter 13 mm

- A - Spotfaced surface dia. 30 mm
- B - Plain stainless steel washer dia. 10 mm
- C - Stainless steel nut H10x150
- D - Earth lug or braid
- E - Sidemember
- F - Stainless steel screw M10x150
- G - Plain stainless steel washer dia. 10 mm

Making an electrical earth

When the rear overhang is modified, it is necessary to find a new location for the electrical earth. Some equipment needs to be connected to earth at a point other than on the originally planned earths. In these cases, the operating procedure is as follows:

- Mill dia. 45 mm, using a shouldered spotfacing cutter (surface finish R 40).
- Tin-coat the surface, using a product containing 40% silver, temperature 230°C, min. thickness 4 μ /mm².

Some equipment items need to be connected to earth at a point other than on the originally planned earths. In this case, use any free drilling (13 mm diameter). Make a spotface to give anti-corrosion protection by means of tin-coating or a zinc aerosol spray prior to assembly. Use 12 mm stainless steel threaded hardware.

Zinc aerosol paint spray ref. N° 77.01.406.425 available from the RENAULT TRUCKS Spare Parts department.

3.2 Chassis earths

- 1 - Chassis earth
- 2 - Chassis earth
- Battery earth
- Starter earth

- 3 - Rear line wiring harness earth
- 4 - Front signalling wiring harness earth
- 5 - Chassis cab earth
- Front signalling earth

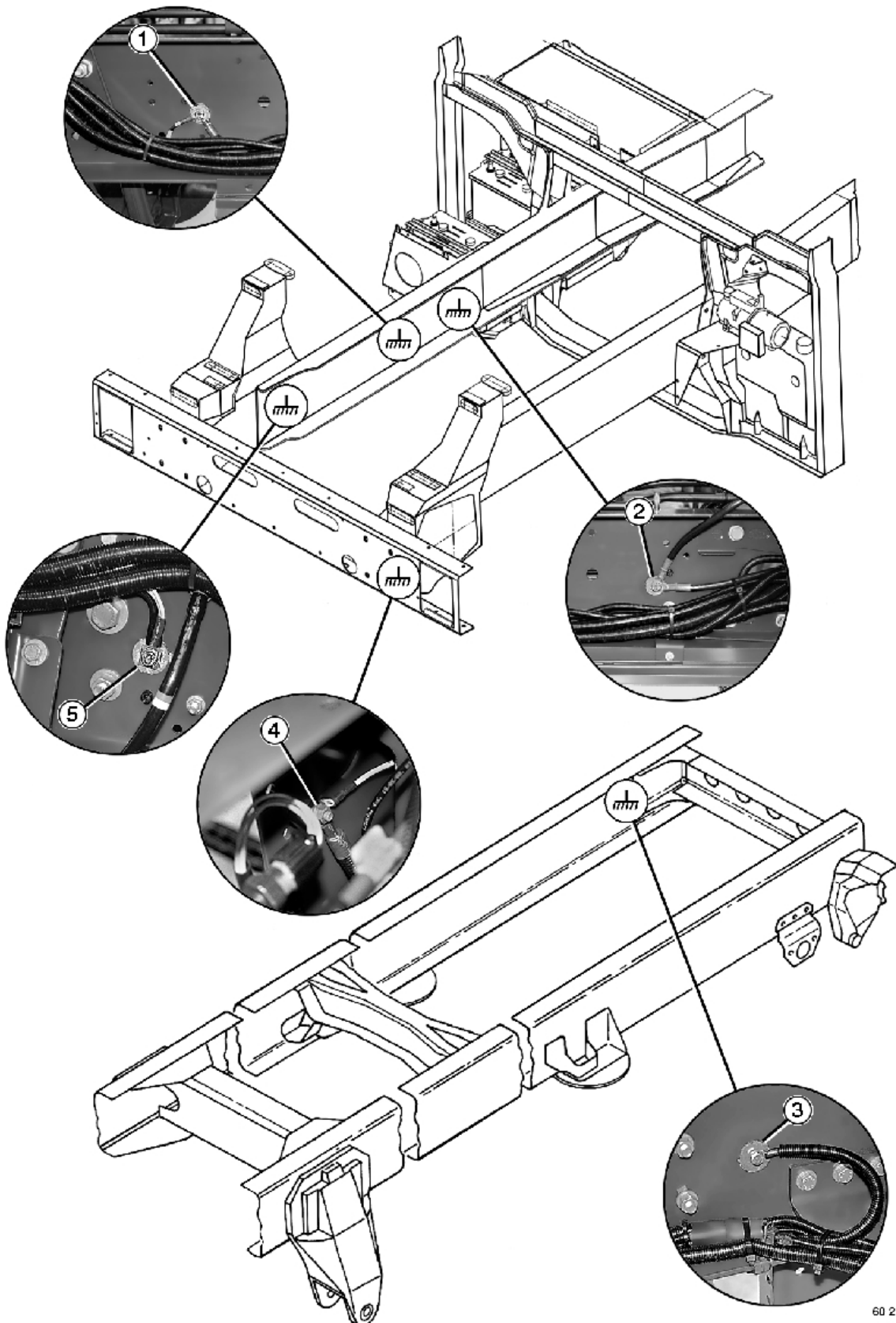

60 2159A

4. CHASSIS

4.1 Sidemember steel grades

The sidemembers comprise two steel grades (see chapter A-2.1.4):

- class D for a minority of cases (marked with an asterisk (*)) in the table below).
- class E for the other cases.

4.2 Sidemember sections

Vehicle Tonnage	(tonne) Wheelbase	(mm) Sidemember	section
4x2 rigid	18/19	5045	290 x 85 x 7 (*)
		5375	
		5705	
		6035	292 x 85 x 8
		6365	
		6695	
6x2 rigid	26	4385	292 x 85 x 8
		4715	
		5045	
		5375	
		5705	
		6365	

4.3 Reinforcement, extension, reduction of sidemembers

If the bodywork or fitted equipment do not modify the chassis weight and dimensions entered in the descriptive notice, the vehicle can be presented to the Type Approval department without intervention from RENAULT TRUCKS (within the permitted limits in force).

In the event of chassis extension, take care to use a section with size and steel grade identical to those of the sidemembers (consult the "Sidemember steel classes and Sidemember sections" chapters). Contact the RENAULT TRUCKS Product Applications Department for any further information or to get a list of sales outlets marketing such sections.

4.3.1 Modification to the wheelbase

For a given vehicle, the section and class of steel for sidemembers depend on:

- tonnage,
- suspension type (air or mechanical),
- wheelbase.

The maximum extended wheelbase length is that of the largest wheelbase on the same vehicle (same tonnage, cab, suspension) fitted with sidemembers of identical section. It is strictly forbidden to overstep this limit.

Vehicles having the maximum permitted length for a given sidemember section cannot therefore have their wheelbase extended.

Shortening of sidemembers in the wheelbase

For 4x2 and 6x2 rigids, it is essential to use "sliding" wheelbases allowing them to be reduced by moving the position of the drive axle (existing holes).

A minimum of two positioning holes are provided for moving the position of the mountings or other components on the chassis - the other attaching holes are to be counter-drilled.

Vehicle Tonnage	(tonne) Wheelbase	(mm) Sidemember	Maximum length of extended wheelbase	Minimum length of shortened wheelbase
4x2 rigid	18/19	5045	5705	
		5375		5045
		5705	extension forbidden	5375
		6035	6695	5705
		6365		6035
		6695	extension forbidden	6365
6x2 rigid	26	4385	6365	
		4715		4385
		5045		4715
		5375		5045
		5705		5375
		6365	extension forbidden	5705

4.4 Intermediate cross-member

After extension of the rear overhang or the wheelbase:

The fitting of an intermediate cross-member or relay cross-member is vital if the number of cross-members in the extended vehicle is less than those for the corresponding standard vehicle.

It is therefore essential to consult the 1/20 scale bodybuilder's drawing for the vehicle with lesser or equal wheelbase so as to find out which cross-members are to be added.

Note

The cross-member that may have to be added will be different depending on the place where the sidemember is sectioned for the purpose of extension. It is therefore strongly advised, before proceeding with cutting, to determine:

- if there is any need to add a cross-member,
- the point where the fitting of the cross-member will be the easiest (e.g. fitting of a simple cross-member rather than a relay cross-member). Consult the RENAULT TRUCKS Product Applications Department.

Procurement

On account of the diversity of assemblies, consult the RENAULT TRUCKS Product Applications Department to find out the reference number and position of the cross-member to be added.

Threaded hardware to be used for fastening cross-members to chassis:

- collar bolts HM14 x 150x 40 class 10.9
- flanged locknuts DRH M14.

Tighten to torque (See chapter A-2.5).

Comply with the regulations in force for positioning the lateral lights.

The wiring harnesses for the lateral lights must be fastened and protected against heat radiation (electric retarder and exhaust in particular).

5. ASSEMBLY OF EQUIPMENT TO CAB

5.1 Installation of air horns

Drill six fixing holes dia. 7 mm and two holes dia. 22 mm for the passage of the flexible pipes at position (A).

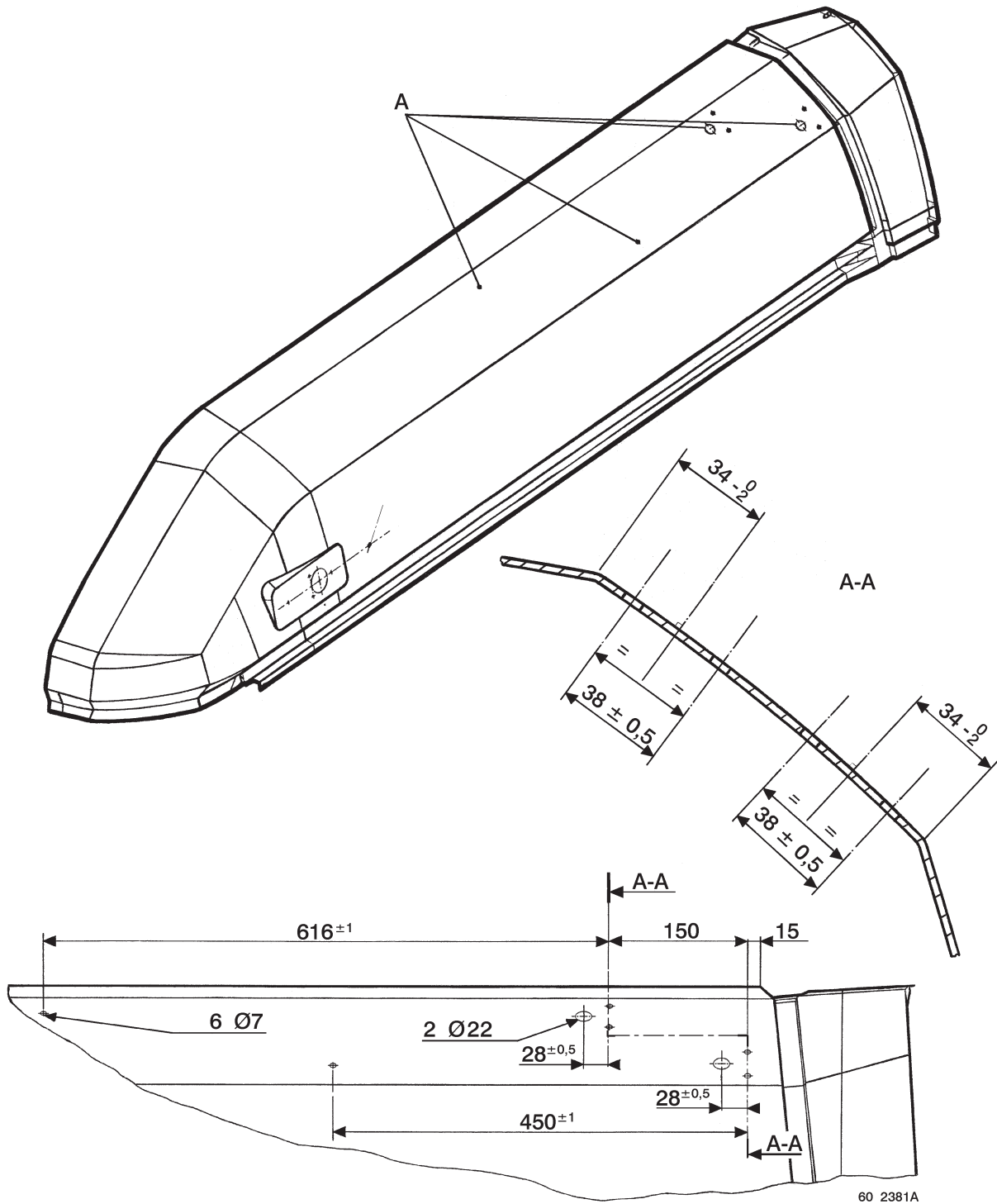

5.2 Installation of CB radio antenna

Drill one fixing hole dia. 4.5 mm and one hole dia. 13 mm for the passage of the wiring harness at position (B).

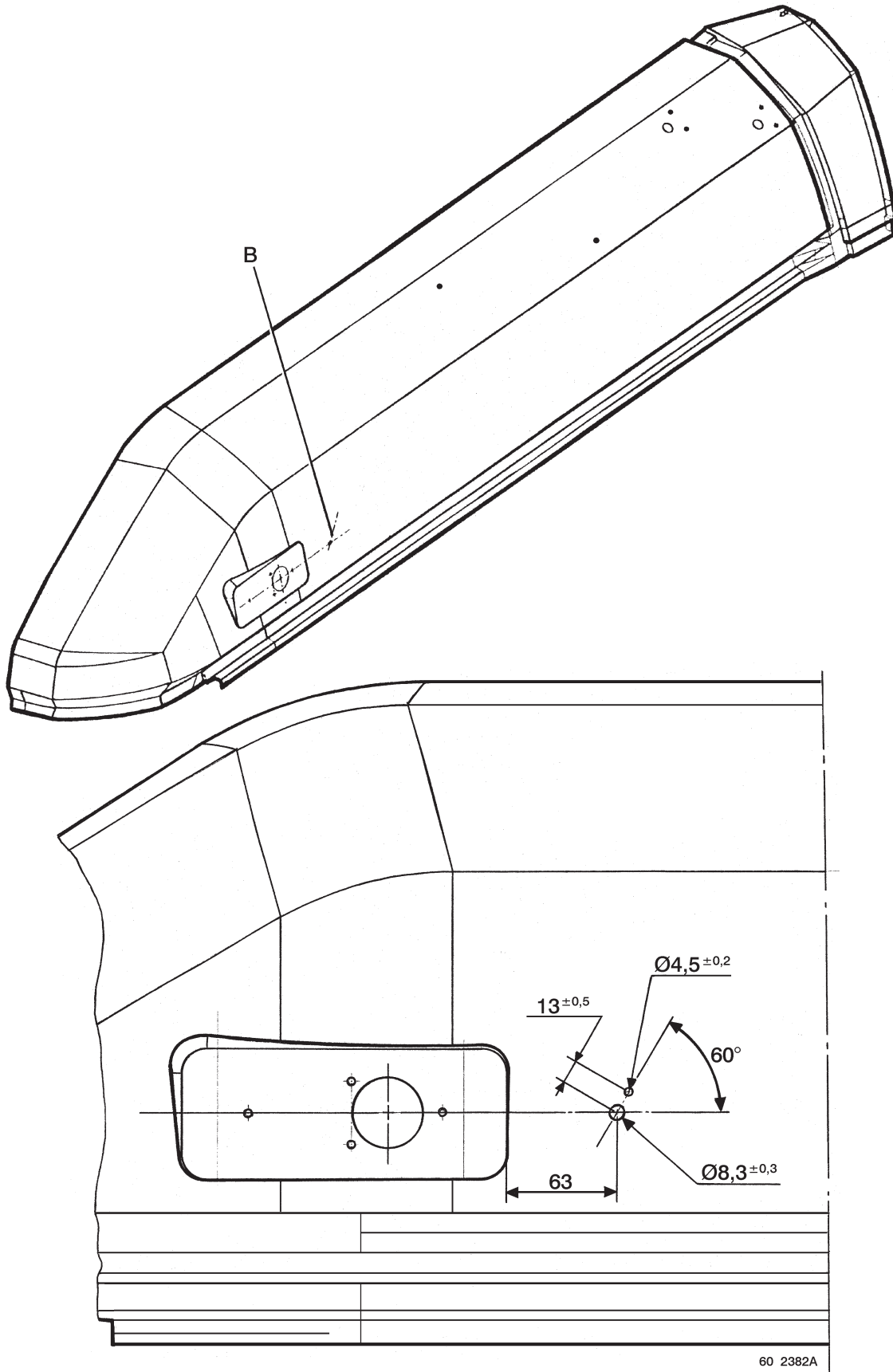

5.3 Installation of radio antenna and telephone antenna

- Drill one fixing hole dia. 16 mm for the telephone antenna.
- Drill one fixing hole dia. 19.5 mm for the radio antenna.

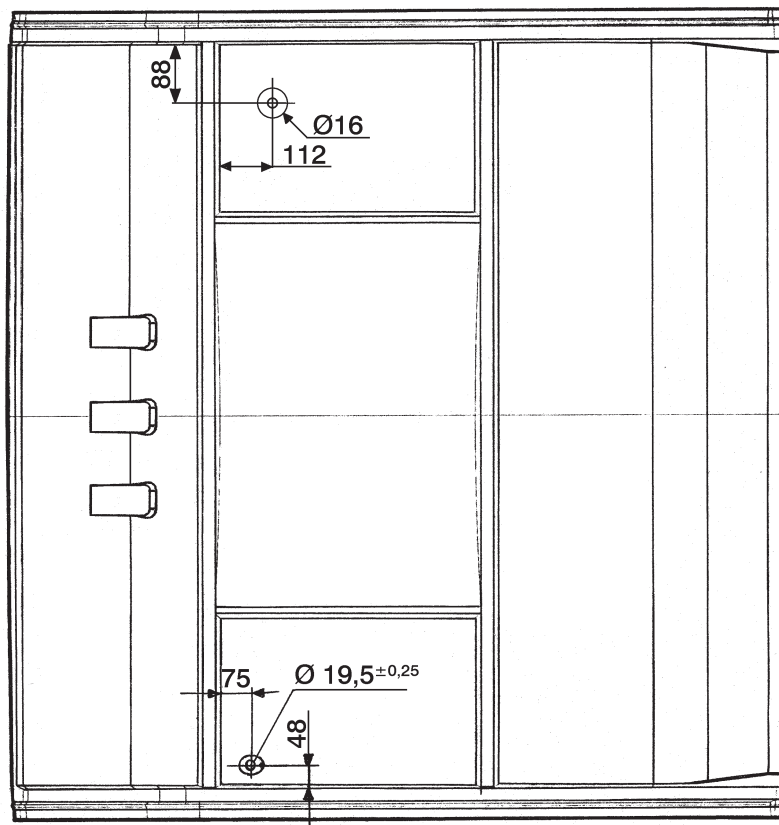

60 2383A

5.4 Installation of roof deflector

Use fixing points (A) on the roof and fixing point (B) on the cab rear end.

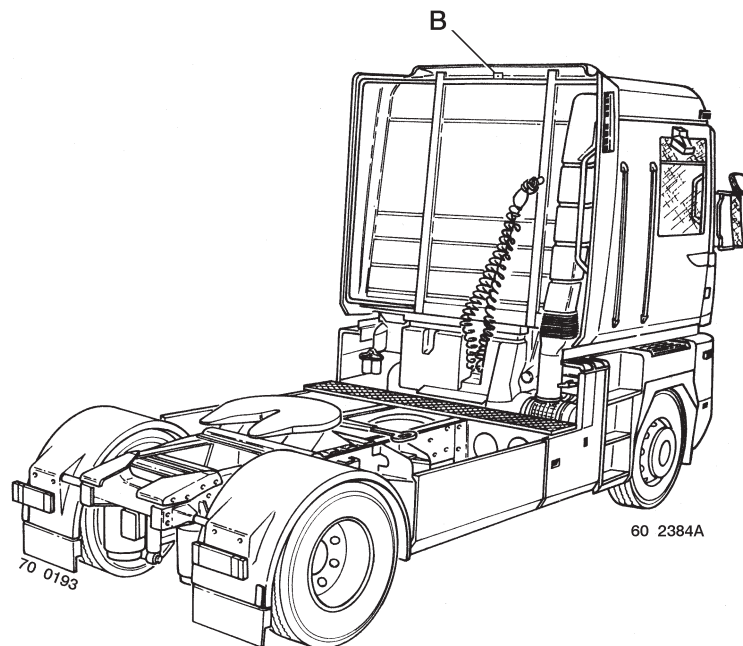
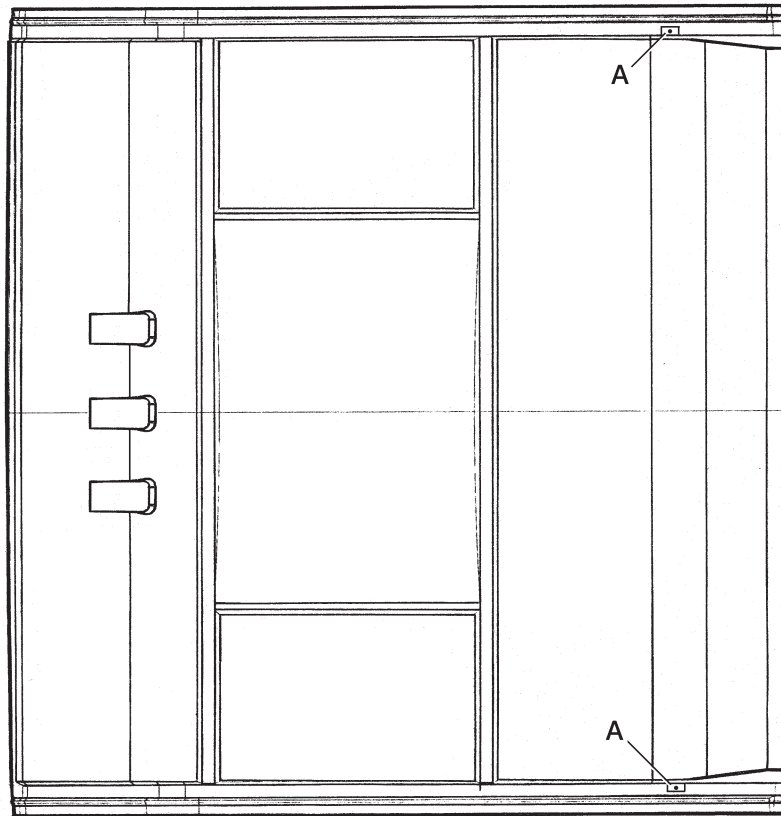

6. AIRBAG

Depending on your vehicle's equipment

IMPORTANT

The fitting of a bull-bar, cattle guard or any other equipment on the front end of the vehicle that might rigidify the chassis is strictly forbidden if an airbag is fitted.

IMPORTANT

Any work on the airbag system must be carried out by qualified personnel who have undergone suitable training.

Identification of a vehicle equipped with an airbag system

A vehicle equipped with a driver's airbag can be identified by:

- the inscription "airbag" in the middle of the steering wheel.
- a sticker placed in the bottom corner of the windscreen, on the driver's side. (If the windscreen has to be replaced, affix a new sticker in the bottom corner of the new windscreen, on the driver's side).

Work on the vehicle (excluding the airbag) requiring precautions to be taken to avoid inadvertent deployment of the airbag

During repair or adaptation work, the vehicle is not to undergo any significant knocks (hammer blows...) nor is welding work to be undertaken without previously disconnecting the battery and waiting for a period of 5 minutes.

No electrical accessories should be installed, as aftermarket fitment, within the close surrounds of an airbag (loudspeaker or any other appliance generating a magnetic field might cause the airbag to release).

Before removing the steering wheel, it is essential to unplug the airbag module connector so as to avoid any damage.

In the event of any work requiring uncoupling of the steering box universal joint, the roadwheels must be in the straight ahead position and the steering wheel must be immobilized, in order to keep to the mid-point of the rotary switch.

IMPORTANT

- *If an airbag system is fitted, the seat belt must be worn.*
- *If the seat or bench seat designed for the airbag system has to be changed, it must be replaced by a seat identical to the one originally fitted.*
- *Adjust the seat cushion and squab correctly so that the airbag offers optimum protection.*
- *The protective cover must be free from any article (ledge, clock, adhesive, various accessories...).*
- *There should be no objects within the airbag deployment area (dia. 100 cm).*
- *Do not place anything between the dashboard and the passengers.*
- *Do not put your feet on the dashboard nor on the seat as such postures risk causing serious injury. Generally speaking, keep all parts of your body (knees, hands, head...) away from the dashboard.*
- *To avoid any inadvertent deployment of the airbag capable of causing bodily injury, it is forbidden to remove the steering wheel or work on the airbag system.*
Only the RENAULT TRUCKS network is qualified to work on the airbag system.
- *Get the airbag system checked out in the case of accident or if there has been attempted theft of or from the vehicle.*
- *For safety reasons, replace the airbag and the pretensioner every 15 years.*
- *If water is splashed onto or gets into the electronic box located under the driver's seat, replace the box.*
- *Any significant modification to the front end of the vehicle or any overloading of the vehicle may lead to inadvertent release of the airbag system.*
- *When lending or reselling the vehicle, inform the borrower or purchaser of all these conditions. Get him to read the driving and servicing handbook.*

