

Manual Transmission (M3S5/M035S5- HARBIN)

General

Troubleshooting	MTC - 2
Adjustment	MTC - 3
Components	MTC - 7
Specification	MTC - 8

Manual Transmission

Component	MTC - 11
Adjustment	MTC - 12
Removal	MTC - 12
Installation	MTC - 14
Disassembly	MTC - 15
Reassembly	MTC - 23

General

TROUBLESHOOTING

Symptom	Causes	Remedy
Too much noise or abnormal noise	Bearing damaged or have crack	Replace the bearing
	Tooth face is striped or damaged	Check or replace the gear
	The parts of the transmission has interfered with the housing	Check ,repair,adjustment
	There is a lack of gear oil	Lubricate enough gear oil
	The oil is too bad to use or the oil spec is unsuitable	Change the gear oil
	The parts in the clutch housing are damaged	Check ,repair,adjustment
Difficult to shift	The bearing wear away or damaged	replace the bearing
	The adjustment of the clutch is not appropriate, so the clutch do not release enough	adjustment
	Unsuitable adjustment in the shift control system.	Check and adjustment
	The slipping block of SYN. take off	Repair
	synchronizer ring wear away or damaged	Replace the synchronizer ring
	Degree of the oil viscosity is too big	Use the fit grade oil
	The shift forks are damaged	Replace
Jump shifting	Sleeve and clutch cone are damaged	Replace relative parts
	Shift control system is not correctly	adjustment
	Self-lock steel ball is lost or damaged	Restore or replace
	Self- lock spring deforms severely or damaged.	Replace
	Shift forks are deformed or damaged.	Replace
	Bearing is worn-out severely and moves on the axial	Replace
	Locknut is loosed	Screw down according to the standard
Accident shifting	Interlocking ball or interlocking pin has not been assembled or worn-out	Dismantle and inspect, replace or reassemble
Leaking oil	Gear oil is overfull	Bleeder some gear oil
	Oil seal is worn out or damaged	Replace
	Gasket is damaged, or seal gum is not Uniform.	Replace gasket or anew daub Seal gum
	Air-breather is damaged	Replace
	The linking bolt is loosed or don't use the seal gum.	Screw down the bolt or daub seal gum,

Symptom	Causes	Remedy
Bearing is damaged unusually.	The oil is too bad to use or the oil spec is unsuitable	Inspect and replace
	Housing and other parts are too dirty	clean
	Gear oil is too dirty	replace
	bearing is bad	Replace

ADJUSTMENT

1. Cleaning

The parts may be contaminated with dirty oil or sludge. It is necessary to clean the parts. Usual methods include steam cleaning, gasoline cleaning, acid or alkaline solution cleaning, neutral solvent cleaning, trichloroethylene cleaning and magnetic force cleaning. Some parts may be damaged during cleaning. Therefore, careful inspection must be done during cleaning.

1) Metal parts

a. Clean with gasoline

Unlike any other method, gasoline is not able to penetrate or dissolve with sludge. The surface of cleaning part has been precisely machined.

Using a metal brush or other tool to remove sludge and brushing should be done twice.

b. Clean with alkaline treatment

Excellent result can be obtained by using alkaline treatment to clean steel parts and castings. Alkaline treatment is not appropriate for alloy parts.

2) Rubber parts

Mineral oil cannot be used. Alcohol can be used after wipe off the dirt with a piece of clean cloth

3) Corrosion prevention

After ridding up all waste oil and grease of the part surface, a layer of clean oil should be applied on the surface to prevent from corroding

2. INSPECTION

- 1) Before cleaning, the part should be inspected with already prepared measuring apparatus or tool. Judging whether the parts can be reused according to the specified standard. Any damaged part should be repaired or replaced as required. If one of matched parts is worn, the other parts cooperating with it in the assembly should be replaced. (for example, hub and sleeve, synchronizer ring (double cone))

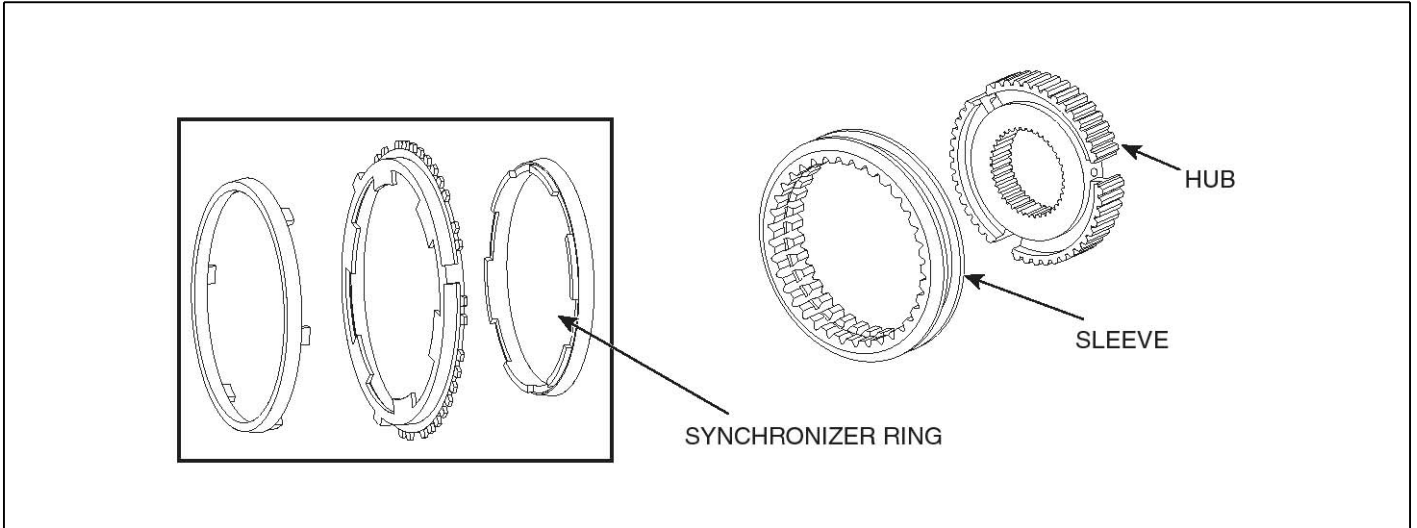

- 2) Some parts have worn limit, for the view point of preventive maintenance, should be replaced before they exceed the limit.

a. The worn limit of shift fork pad is 1 mm.

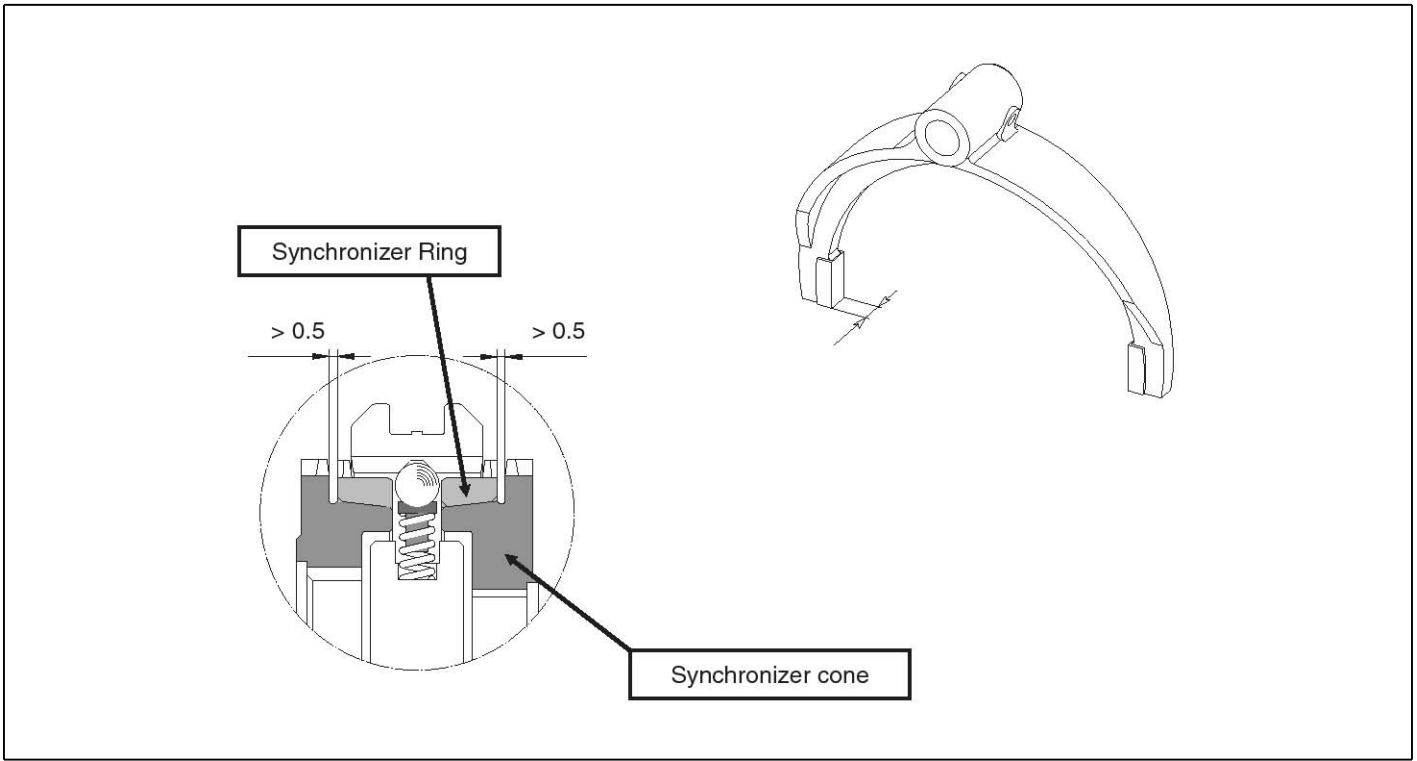

SUDMT7005L

- b. synchronizer ring worn limit not less than 0.5 mm.
- c. the axial clearance of bearing on the main shaft
limit of worn 0.5 mm
- d. The radial clearance between needle bearing and the inner hole of gear.
standard limit 0.049 mm
worn limit 0.20 mm
- 3) All parts should, as necessary, be carefully by visual inspection or by means of NDT such as infrared ray, wave or X ray. The part can be repaired as necessary if any abnormality is found during visual inspection, such as irregular wear, iron rust, bending, deformation, crack, partial wear, discoloration, loose fitting, over abrasion and etc.
- 4) Any rubber part such as O-ring, oil seal or gasket, after disassembled, should be replaced according to the situation.

- 5) Check the dismounted bearing, gear, shaft and any other important parts. For any ablation, flaking off, pockmark or excessive wear or other defect, replacement is necessary.

3. Maintenance and Replacement

⚠ CAUTION

In order to achieve effectively the using performance of the transmission, advice to replace any low-value wear-prone part.

For instance, replacement of any worn gasket, bush or oil seal can make damage of gear or bearing, etc.

Replacement of such parts will not increase the cost for replacement of important parts.

1) Steel parts

For matched parts that can not be repaired, such as gear, bearing, when any damaged part is rejected, replacement the suited part is required as well. That to say, any matched parts should be replaced in pairs manner but not in a single manner

2) Rubber parts

For rubber parts such as oil seal, if it is damaged, must be replaced at once, in this case reuse may not be considered.

3) casting case

Any cracked or bent on the case should be replaced at once.

⚠WARNING

Never try to repair any housing by means of welding or straightening; otherwise, the housing may become defective during use of vehicle, possibly causing serious result.

4. Notice of using the transmission

1) While driving, you should check the clutch pedal step board usually, looking into whether clutch separates thoroughly and complete coalescence or not. Otherwise it will influence the function of gear shifting and SYN lift span

2) You should use the high gear possibly, launching the engine to be placed in the economy speed-changed area, to enhance the motive and economy.

3) While driving, you should not suddenly accelerate and reverse rapidly.

4) When the vehicle start, you should make the gearbox is at neutral position, complete coalescence of clutch. Driving slowly 3-5 minutes, making use of the wheel gear oil of splash, make each wheel gear, full lubrication of SYN and bearings, otherwise it will influence the function and life span.

5) Gearbox should not run down at neutral position, change to high gear while going down the ramp. Now the rear wheel push the drive shaft running fast, which making the output shaft running fast, now if the gearbox changes to neutral position, the countershaft running slowly, thus it will be burned SYN and bearing.

6) The shift must be stable and not hurried, the correct shift as follow:

The clutch should be thoroughly stepped (The seat of the driver must be correctly adjusted), and stable pushing the shift lever to the required position. The synchronizer will play function, when the shift meet resistance at the some position. The power acting on the shift lever should be gradual but not suddenly push, then the shift will be easily shifting after part second.(synchronization time).

Notice: The shift from high gear to low gear is more difficult than the shift from low gear to high gear under the natural instance.

7) While wanting to shift reverse gear, you must stop the vehicle then shift gear.

8) While shifting gear, the clutch pedal should trample exactly, move the gear control lever to the requiring position.

5. Repair procedure - 2nd / 3rd synchronizer chamfer

NOTICE

The chamfer angle of 2nd/3rd synchronizer outer ring and sleeve was changed from 104 ° to 100 ° on 2008-01-18.

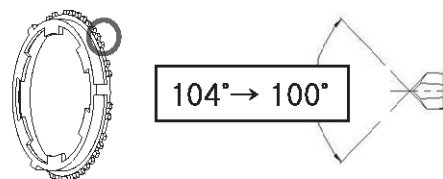

the chamfer angle of 2nd/3rd synchronizer outer ring

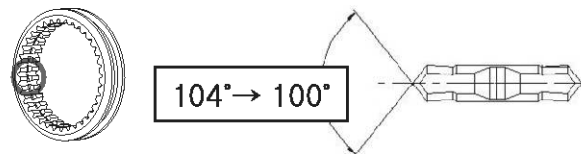

the chamfer angle of 2nd/3rd synchronizer sleeve

SUDMT8001L

1) How to replace the parts when the 2nd or 3rd double cone synchronizer is wear.

a. The transmission was produced prior to 2008-01-18.

Replace the 2nd/3rd synchronizer cone assembly and sleeve at the same time.

b. The transmission was produced since 2008-01-18.

Replace only the 2nd or 3rd synchronizer cone assembly.

2) How to replace the parts when Outer/Middle/Inner ring of 2nd or 3rd double cone synchronizer is damaged each.

Replace only the 2nd or 3rd synchronizer cone assembly. Do not replace the parts each.

3) How to check the production date.

Check the production date that is located in the side of transmission.

Components (Main Shaft Assembly)

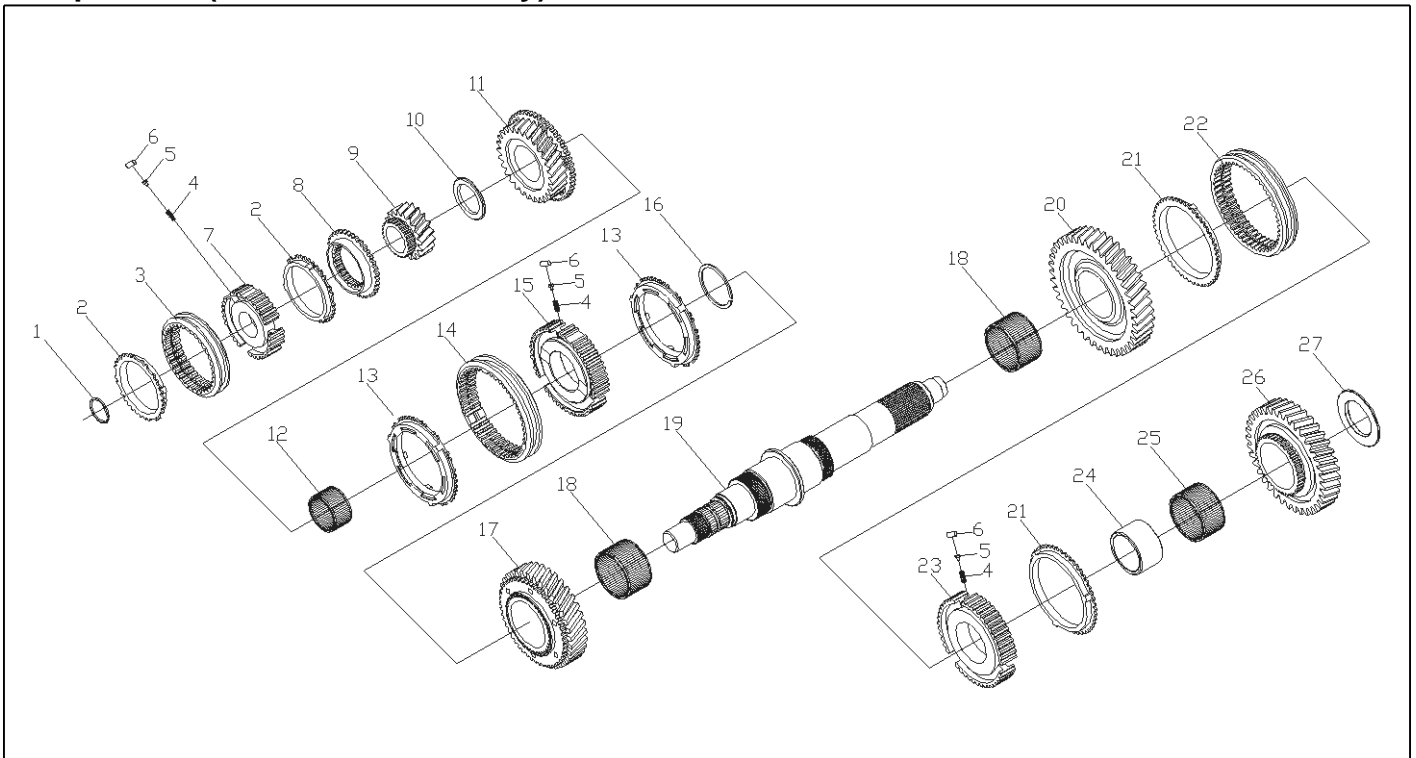

SUDMT8002L

- | | |
|--------------------------------------|------------------------------------|
| 1. Snap ring - 4th/5th speed hub | 14. Sleeve-2nd/3rd speed syn. |
| 2. Synchronizer ring - 4th/5th speed | 15. Hub-clutch 2/3 |
| 3. Sleeve - 4th and 5th speed | 16. Snap ring-2nd/3rd Syn.hub |
| 4. Syn. Slide block spring | 17. 2nd speed gear & cone assembly |
| 5. Syn. Slide block spring seat | 18. Needle bearing |
| 6. Short cylindrical roller - Syn. | 19. Maninshaft |
| 7. Hub-4th and 5th speed Syn. | 20. 1st speed gear |
| 8. Syn. Cone -5th speed | 21. Clutch gear-reverse gear |
| 9. 5th speed gear | 22. Sleeve - 2nd/3rd speed Syn. |
| 10. Washer-3rd speed gear | 23. Hub -clutch 1/R |
| 11. 3rd speed gear & cone assembly | 24. Bushing - reverse gear |
| 12. Needle bearing | 25. Needle bearing |
| 13. Cone assembly-2nd/3rd Syn. | 26. Reverse gear |
| 13-1. 2/3 outer - Syn. Ring | 27. Washer-reverse gear |
| 13-2. 2/3 middle cone - Syn. Ring | |
| 13-3. 2/3 inner-Syn. Ring | |

SPECIFICATION

Transmission model		M3S5(HARBIN)	M035S5(HARBIN)
Engine model		D4AL, D4DC, D4DBD	D4DA, D4DB, D4DC, D4DD
Oil type	Temperate & frigid zone	SAE 80W/90(GL-4)	
	Tropical zone	SAE 90(GL-4)	
Oil cubage(Liter)		4.2	4, 4.8(with PTO)

SERVICE STANDARDS

Description	Nominal value	
Gear ratio	1st	5.591
	2nd	2.87
	3rd	1.607
	4th	1
	5th	0.742
	REV.	5.045
Gear backlash (mm)	1st	0.152~0.416
	2nd	0.12~0.336
	3rd	0.112~0.316
	4th	0.12~0.336
	5th	0.25~0.57
	REV(C/S~Rev.Idler)	0.134~0.398
	REV(Rev.Idler~M/S)	0.126~0.378

LUBRICATION

1. Recommended gear oil

The transmission gear must be used SAE80W-90(GL-4) or SAE90(GL-4) oil.

- Quantity : 4.2 Liter
- In tropical zone : SAE 90 (GL-4) for 4.2 L
- In temperate or cold zone : SAE 80W-90 (GL-4) for 4.2 L

2. Period of changing Gear Oil

: For every 8000 Km travel, inspect the gear oil level and fill as specified.

3. Period of changing oil for transmission:

- 1) Replacing the oil after having finished running about 5000 Km of travel or 125 hours for the first time.
- 2) The oil must be changed after every 20000 Km of travel or 2000 hours, and the period of changing oil is less than one year.

4. Specific operating instruction for changing gear oil

The filler plug is on the side of housing.

The oil should be filled until the oil level is flush with the access hole.

NOTICE

Change of gear oil should be carried out in warm condition.

Be careful not to be hurt with hot oil.

Clean the impurity from the oil drain plug.

Tightening torque(Main bolt 1)

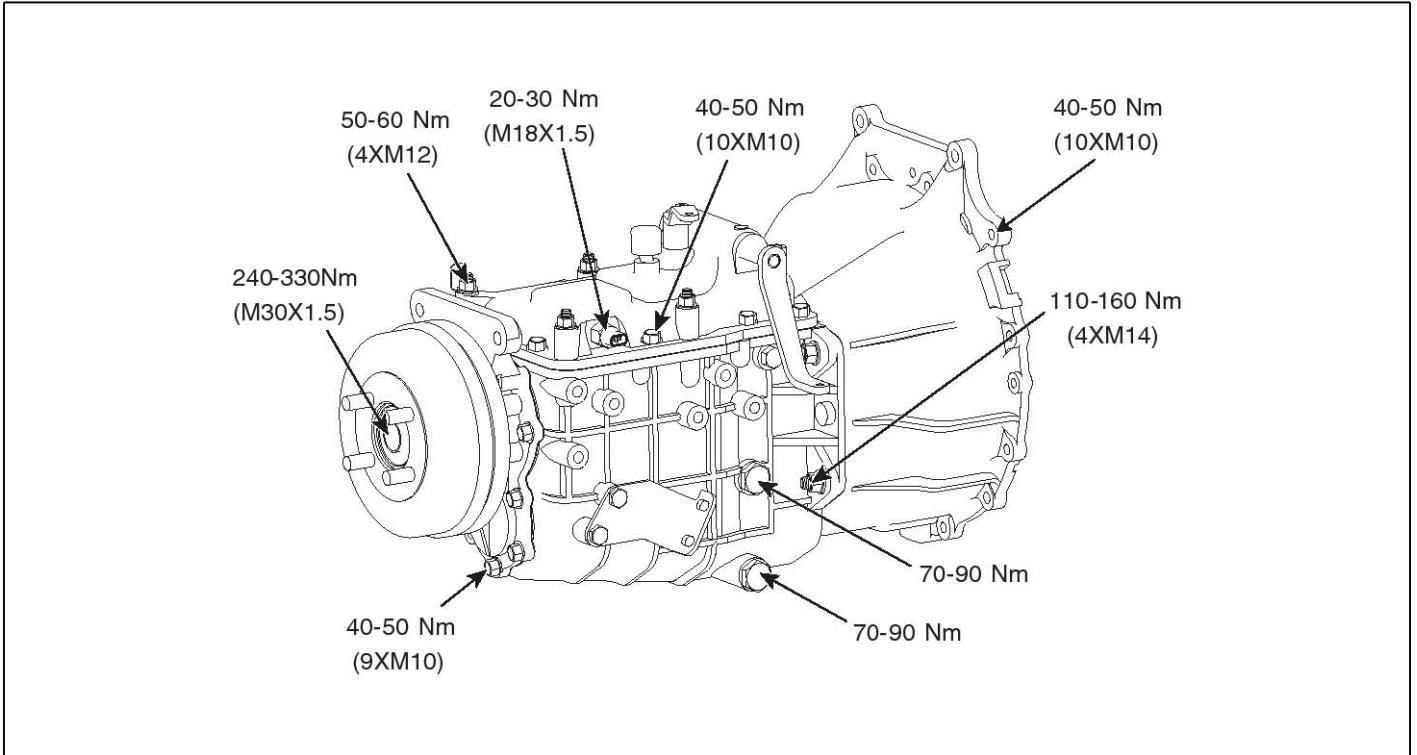

SUDMT7001L

Tightening torque(Main bolt 2)

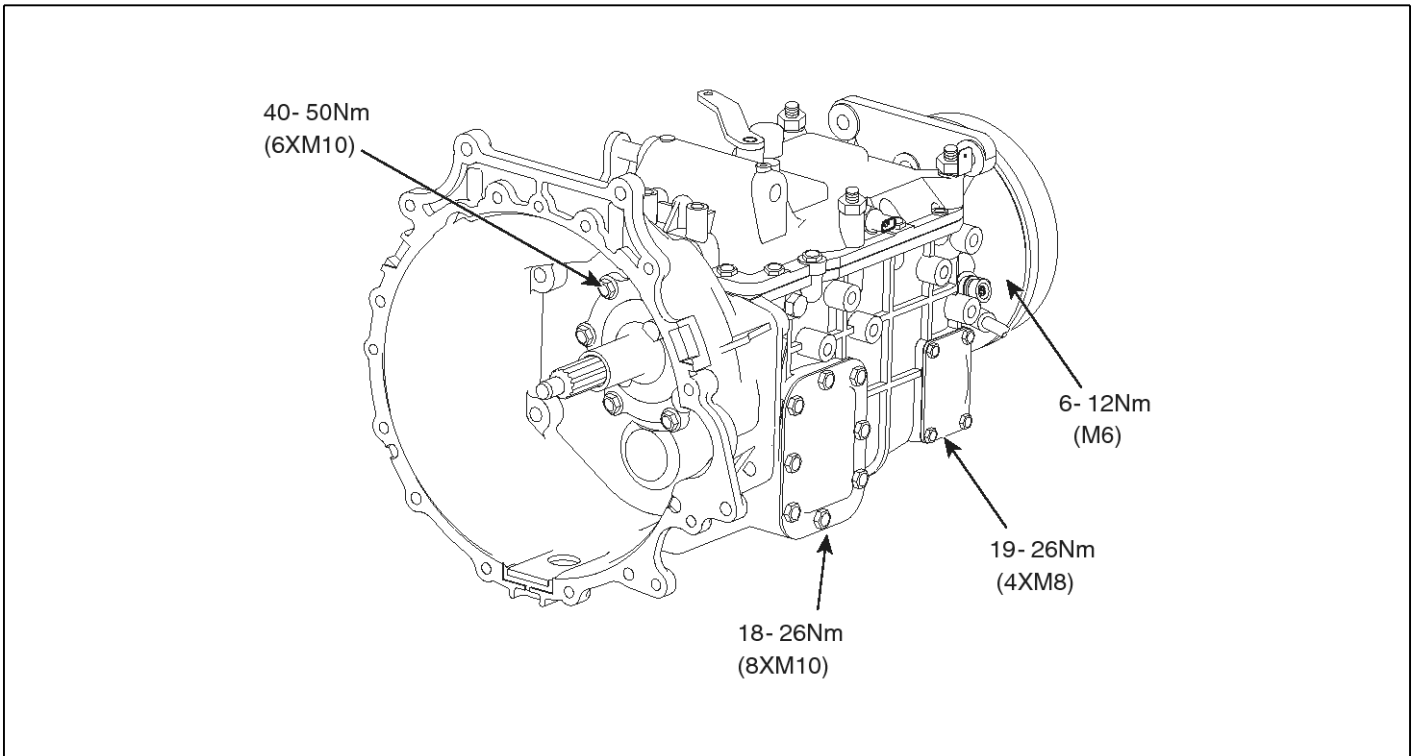

SUDMT7002L

Tightening torque (drum side)

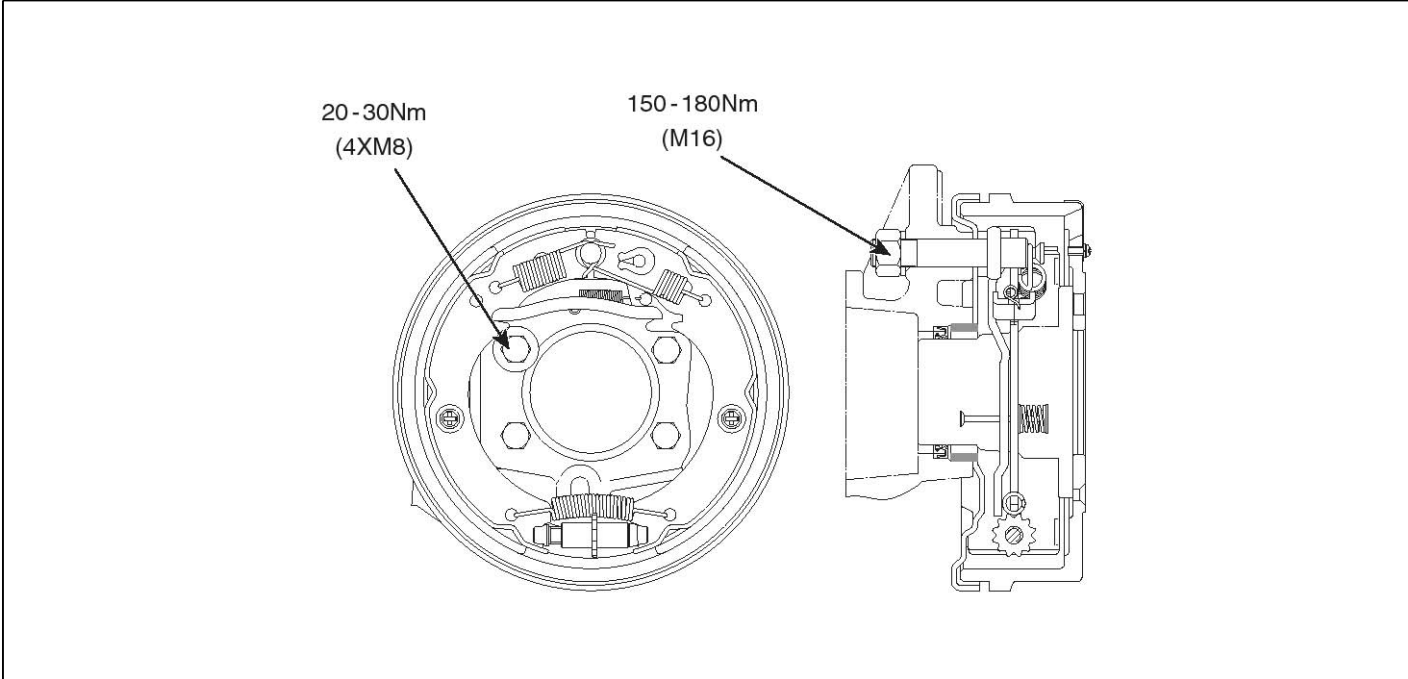

Manual Transmission

COMPONENT

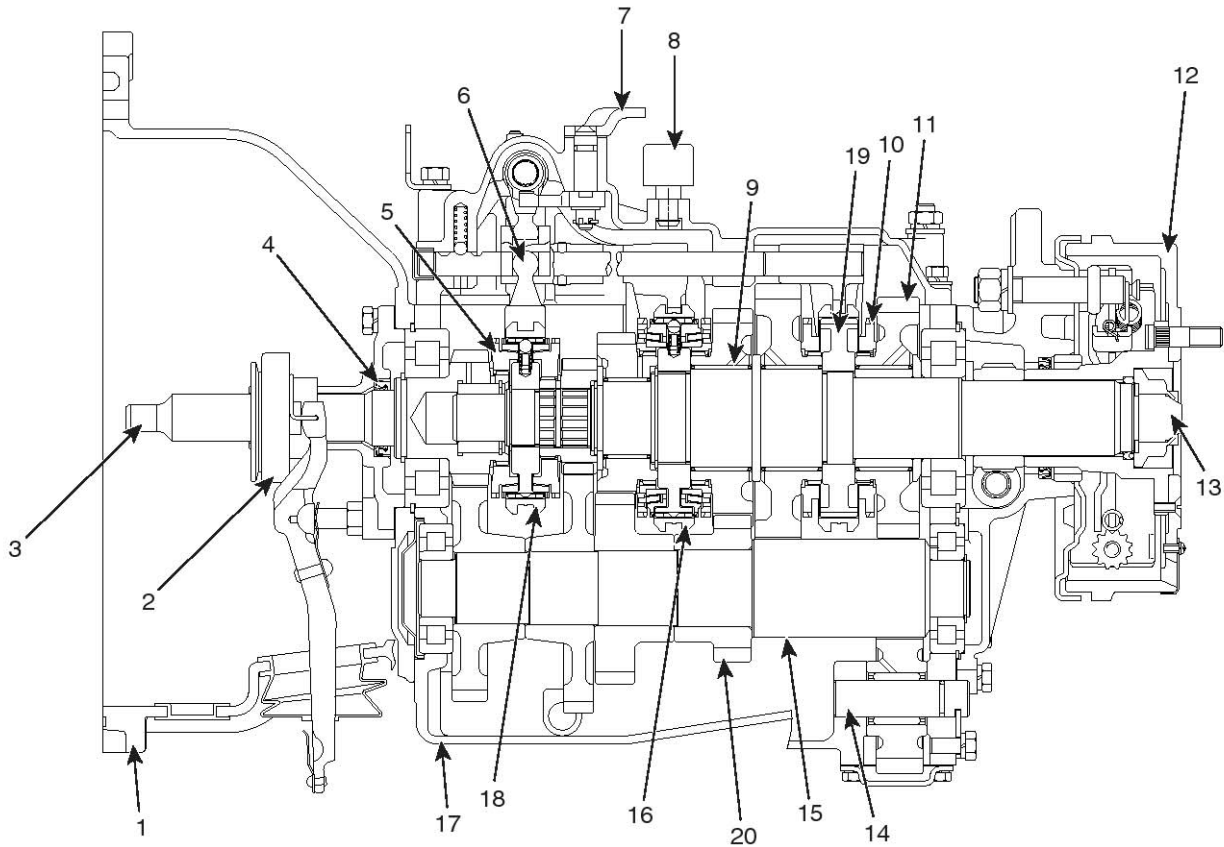

1. Clutch housing
2. Clutch release bearing
3. Input shaft
4. Oil seal
5. Input shaft synchronizer cone
6. 4/5th shift fork
7. Select lever and arm assembly
8. Air breather
9. Needle bearing
10. Clutch gear
11. Reverse gear
12. Parking brake
13. Main shaft
14. Reverse idler shaft
15. Counter shaft
16. Clutch 2/3 sleeve
17. Gear box housing
18. 4/5th synchronizer sleeve
19. 1/Rev clutch hub
20. Counter shaft 2nd speed gear

SUDMT7006L

KMTTM5513A

ADJUSTMENT

Notice of dismantling and decompose transmission

1. Before dismantling the transmission from the vehicle, must park the vehicle at a flat safety place ,and transmission should be at neutral. the power should turn off to insure the safety.
2. Before decomposing the transmission assembly , should clean transmission thoroughly.
3. Decomposing of the transmission must be carried through at a clean place, avoid the dust going into the transmission. Otherwise, it will turn worse wear away to the parts.
4. When dismantling bearings , should use the special tool , thus it is easy to dismantle , and won't damage the bearings. Bearing should be cleaned carefully.
5. when dismantling and decomposing , must notice the sequence and methods.Dismantling some parts should use special tool .
6. When decomposing each branch assembly, must put all the parts at a clean place .thus can avoid the parts losing , and will make it is very easy to assembly.
7. To notice assembling and dismantling the synchronizer cone and synchronizer ring in pairs manner to avoid mix.
8. When using the tool to dismantle the parts, must notice the power on the parts ,can't damage them, must use copper hammer or copper stick.
9. Housing ,the bearings cover,the position of seal, need to remove seal gum and the gasket broken after dismantling.

Removal

1. Place the wooden block(A) to the front and rear sides of the both(LH/RH) sides rear wheels.

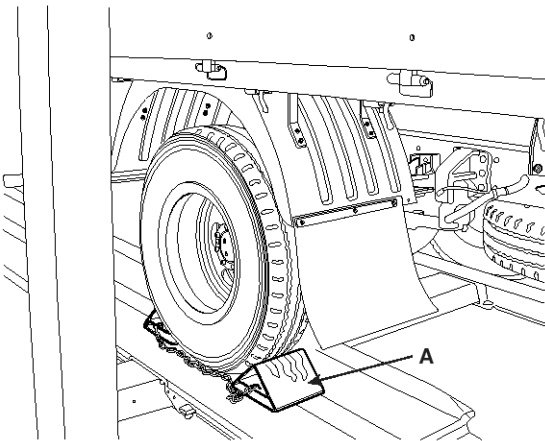

2. Disconnect battery (-) cable(A) from the battery.

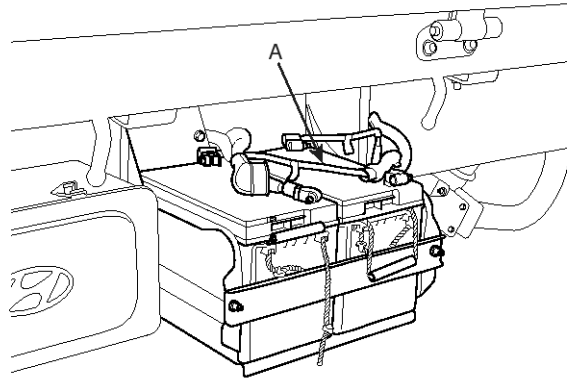

KMTTM5514A

3. Lift up the axle using a garage jack (A) and support the frame with a safety stand (B).

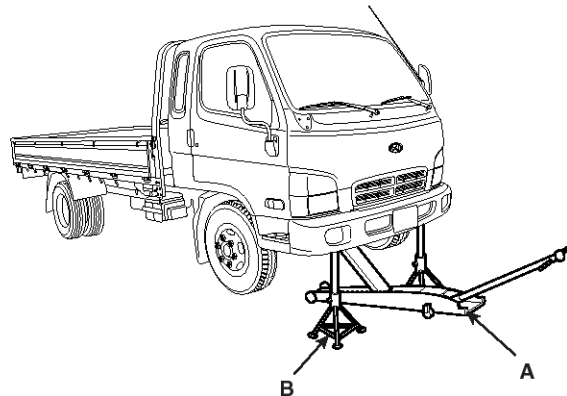

SUDMTA7001L

4. Remove the propeller shaft(A) from the transmission.

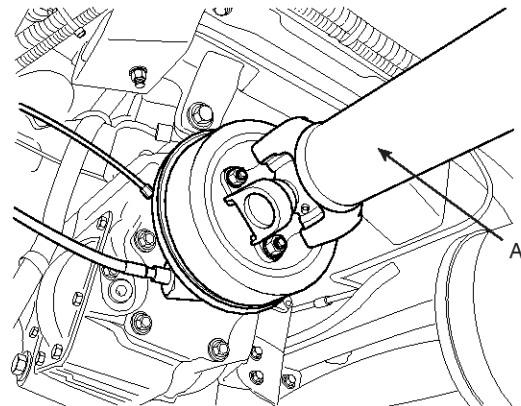

SUDMTA7002L

5. Remove the parking brake drum cover. Remove the parking brake assembly(A).

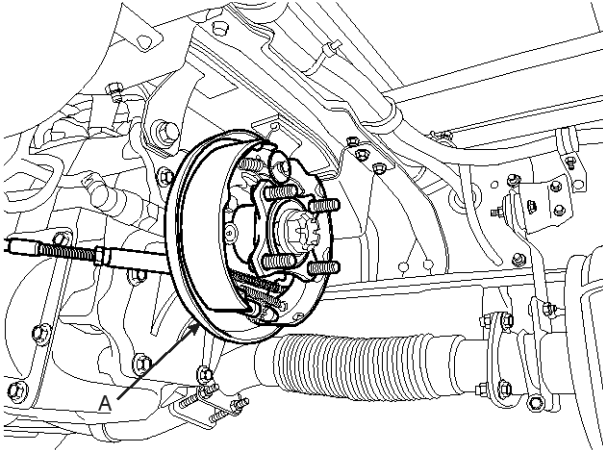

SUDMTA7003L

6. Remove the exhaust brake assembly(A), if equipped.

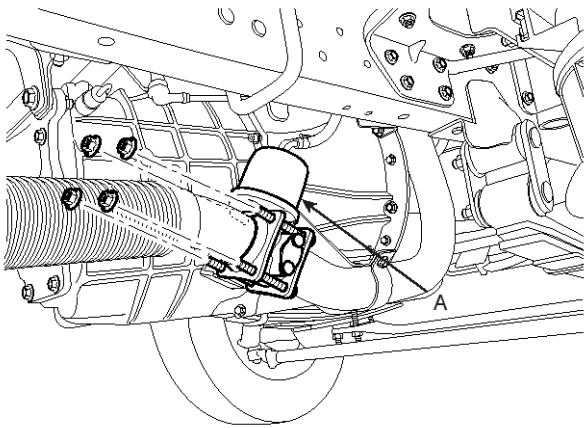

SUDMTA7004L

7. Remove the exhaust pipe mounting bracket(A).

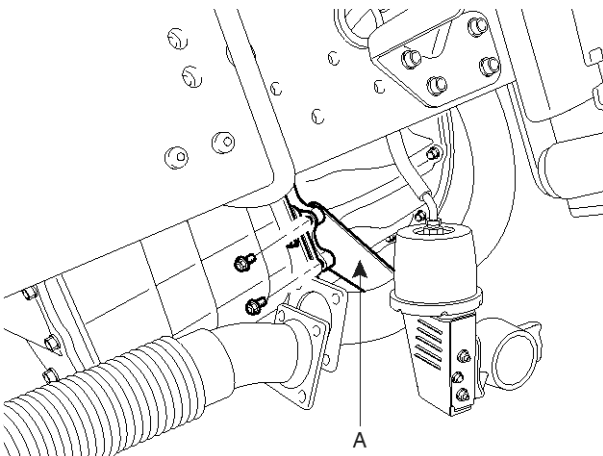

SUDMTA7005L

8. Remove the release cylinder assembly(A).

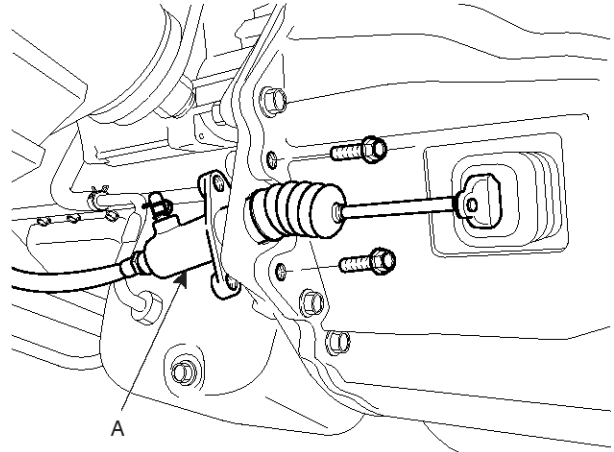

SUDMTA7006L

9. Disconnect the speed sensor connector, crank position sensor, back-up switch connector and neutral switch connector from the transmission.
10. Remove the shift cable and selector cable from the transmission.

NOTICE

Put the transmission to the neutral position before removing the shift cable and the select rod from the transmission.

11. Support the transmission(A) with a jack(B) and remove the body mounting bolts and engine mounting bolts. Then remove the transmission from the engine.

CAUTION

Be careful not to fall down the transmission.

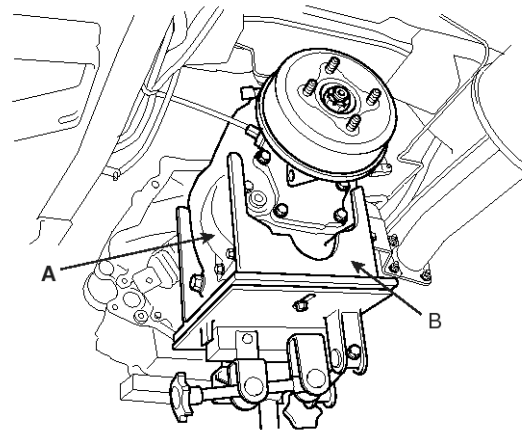

KMTTM5519A

NOTICE

If the transmission is not separated from the engine, detach the transmission by inserting a flat drive into grooves on the clutch housing.

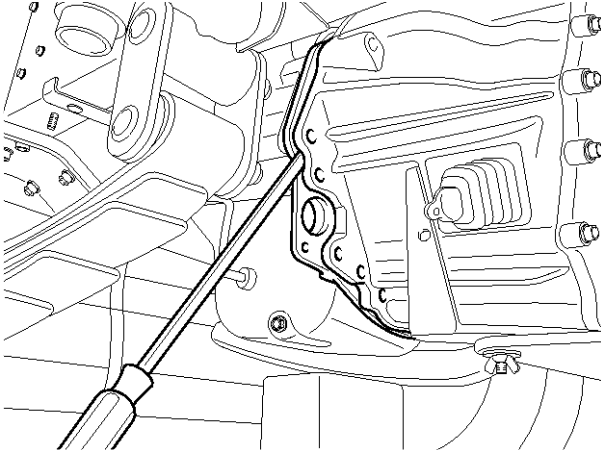

SUDMTA7007L

12. Remove the mounting bolt connected with a vehicle in the rear side of transmission.

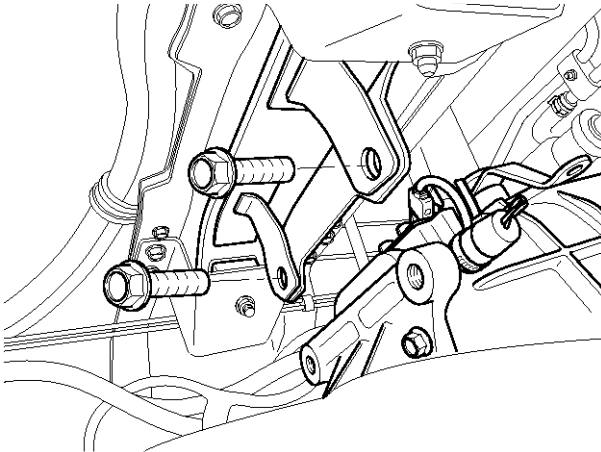

SUDMTA7008L

DISASSEMBLY

INSTALLATION

NOTICE

Before assembling the transmission, it is important to check the transmission.

1. It must be free to shift any gear.
2. There should be no too much noise or abnormal noise in transmission.

CAUTION

Pay attention to the safety of human body and properties of other people and your own.

The T/M ASSY assembled according to the following steps:

1. Use the steel cable rope hang the transmission or put a jack under the transmission, assembling the transmission
2. Assembling the T/M assembly with fly wheel housing.
3. Assembling the clutch cylinder assembly
4. Assembling drive shaft assembly at the back of transmission.
5. Assembling the wiring harness which connected with transmission.
6. Assembling the sensor of the speedometer connected with transmission.
7. Assembling the bracket linking exhaust pipe.

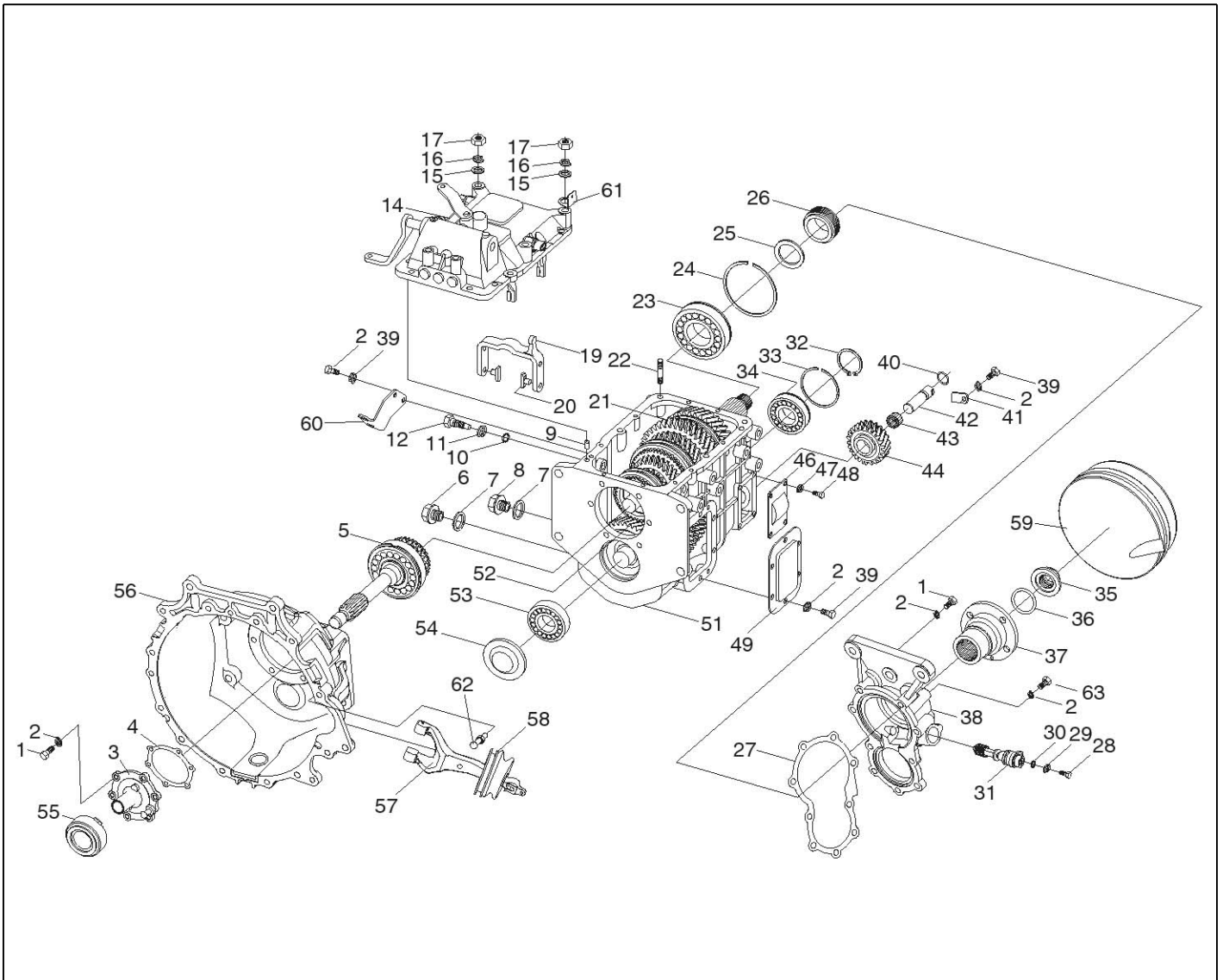

MTC-16

Manual Transmission

1. Screw off the drain plug, drain the gear oil off.

CAUTION

Clean the impurity from the oil drain plug.

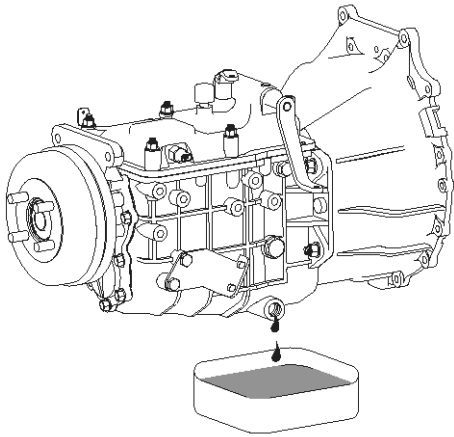

SUDMT7008L

2. Dismounting of release fork and release bearing.
Important prompt: the parts shall be lay on the soft surface, so to prevent parts from damaging.

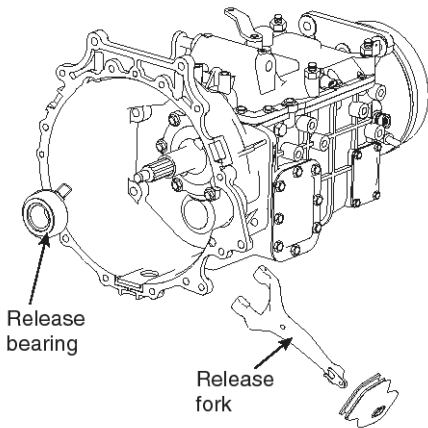

SUDMT7009L

3. Dismounting of first bearing cover and gasket

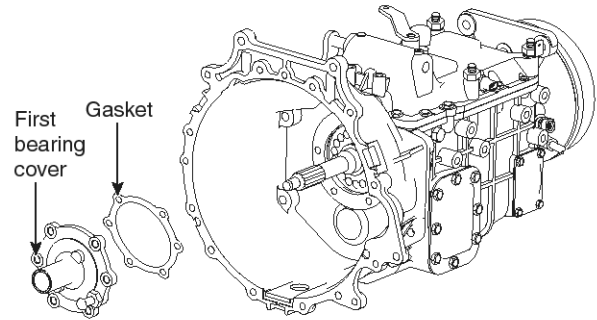

SUDMT7010L

4. Take down the clutch housing.

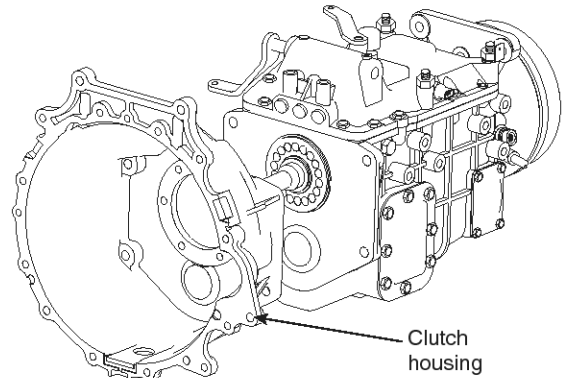

SUDMT7011L

5. Screw off two bolts on the brake drum.

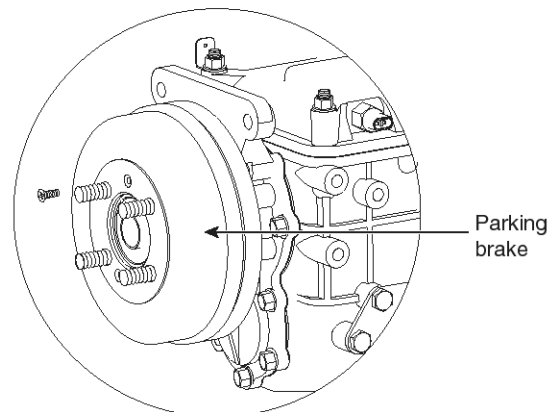

SUDMT7012L

6. Take down the brake drum.

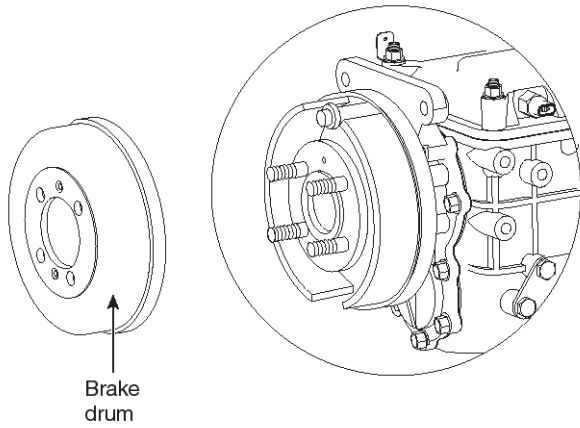

SUDMT7013L

7. Screw off locking nut.
Take down the O-ring and flange.

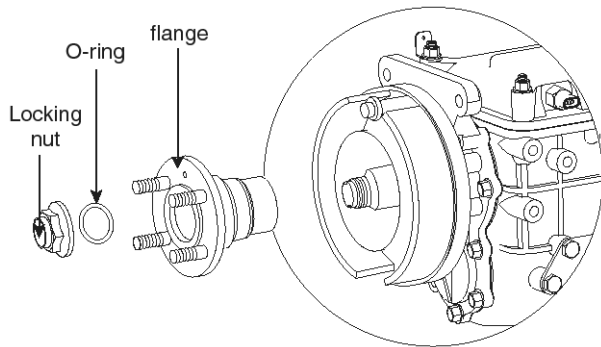

SUDMT7014L

8. Screw off the nut and four bolts linking parking brake.
Then take down the parking brake.

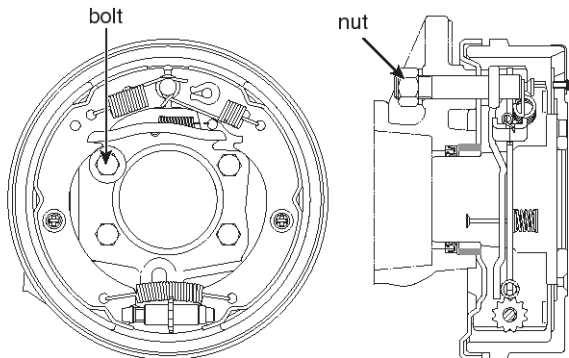

SUDMT7015L

9. Dismantle the upper cover assembly

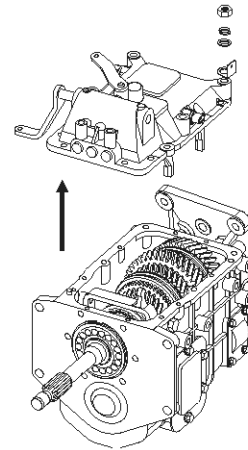

SUDMT7016L

10. Take down the rear bearing cap assembly and the gasket

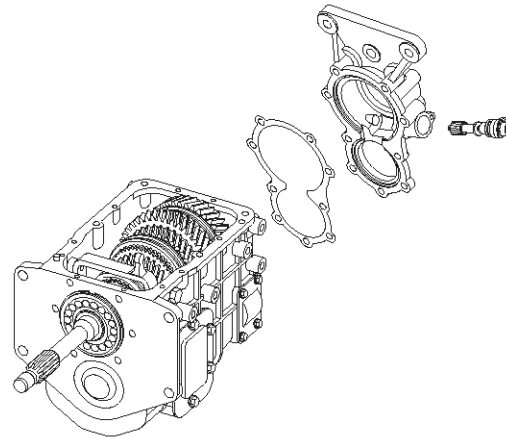

SUDMT7017L

11. Screw off the support bolt - shift fork.
Take down the shift fork-4/5th.

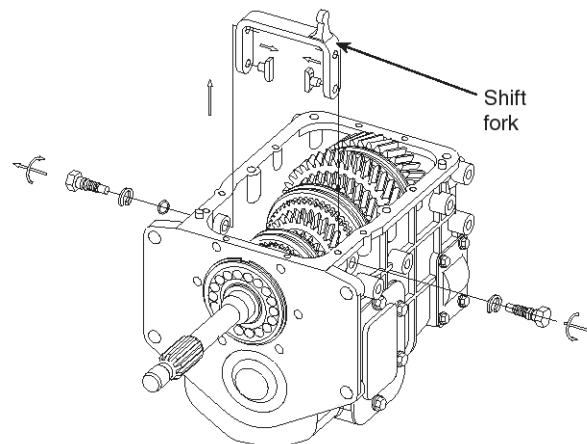

SUDMT7018L

12. Take down the input shaft assembly.

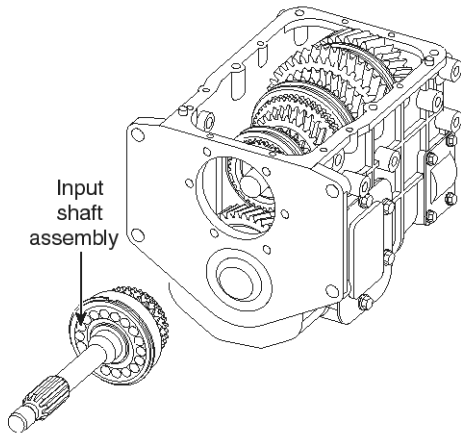

SUDMT7019L

13. Take down the snap ring with pliers.

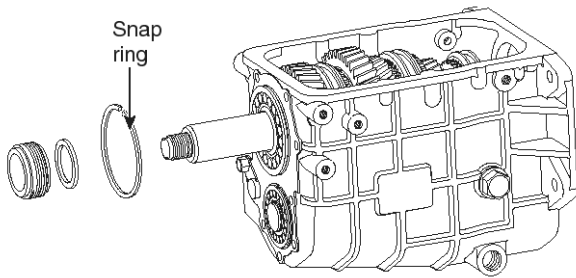

SUDMT7020L

14. Pull out the bearing by special tool(see fig.A)

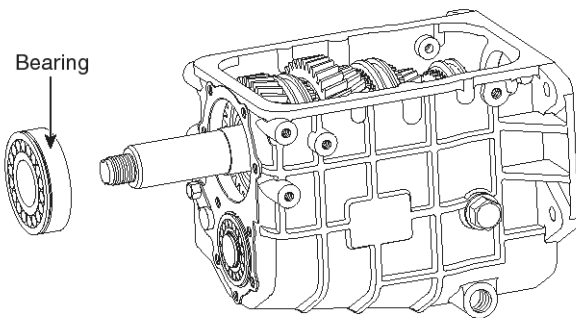

SUDMT7021L

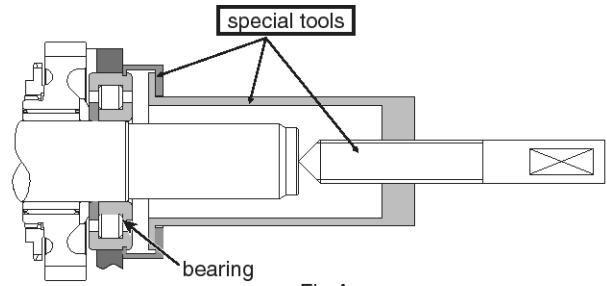

Fig.A

SUDMT7022L

Prompt:dismantling tools indicated in figure is only as schematic in use. Under the premise of not damaging component, a user can select tools with similar functions for dismantling by himself.

15. Take out the main shaft assembly from T/M housing.

Pay attention to don't let the parts in synchronizer assembly jump out.

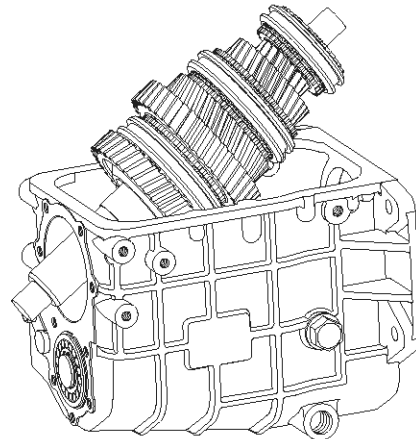

SUDMT7023L

16. Take down the snap ring with pliers.

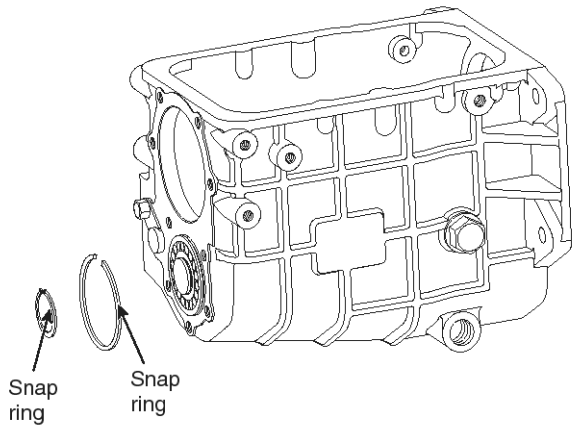

SUDMT7024L

17. Pull out the bearing with special tool.

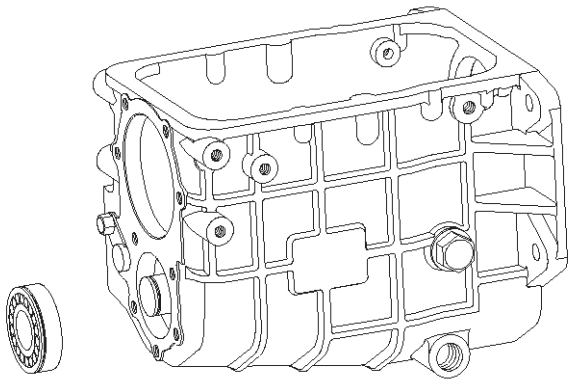

SUDMT7025L

18. Take out the countershaft assembly from T/M housing.

The countershaft assembly can't be disassembled.

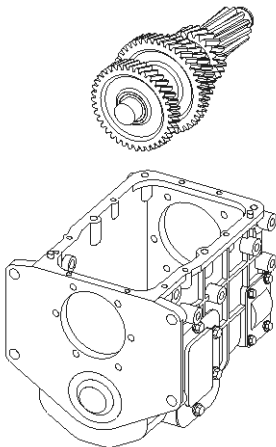

SUDMT7026L

19. Take down the idler gear and idler shaft.

If the cover is not be damaged, it is not necessary to dismantle.

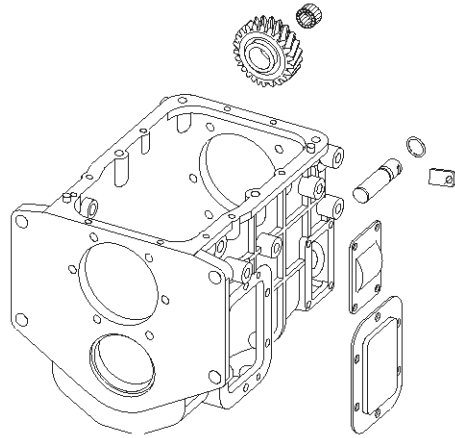

SUDMT7027L

20. Take down the front bearing-countershaft and the cover

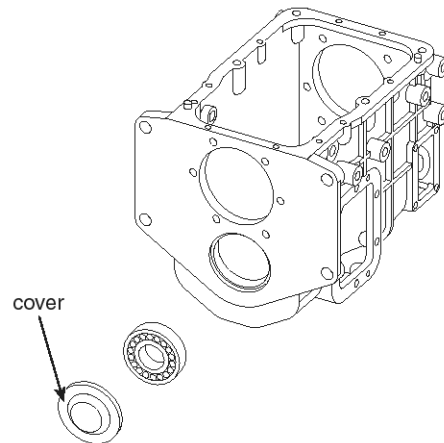

SUDMT7028L

DISASSEMBLY(MAIN SHAFT)

1. Take down the snap ring with pliers.

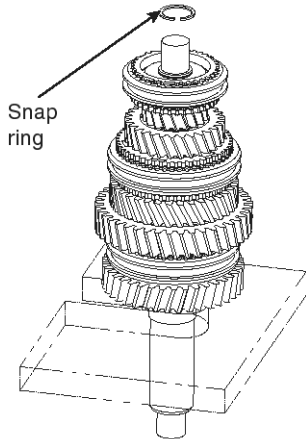

SUDMT7029L

2. Take down the 4th/5th synchronizer ASSY.
Pay attention to don't let the parts in synchronizer ASSY jump out.

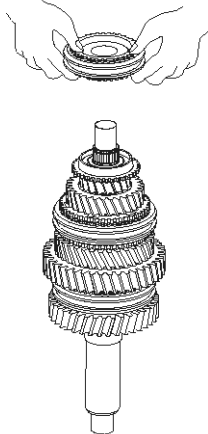

SUDMT7030L

3. Dismantle the 5th gear and synchronizer cone assembly.

CAUTION

Don't lay any gear on hard surface.

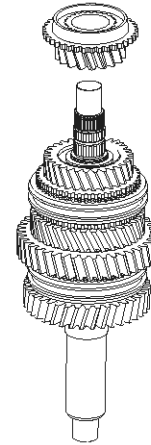

SUDMT7031L

4. Take down the snap ring with pliers.
Then take down the washer.

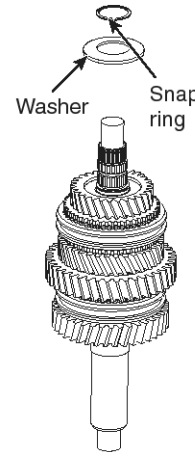

SUDMT7032L

5. Dismantle the 3rd gear and clutch gear assembly.
Then take down the needle bearing.

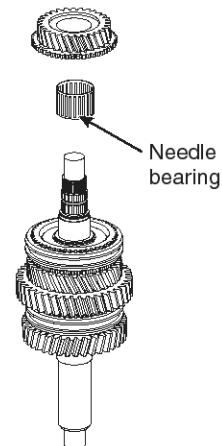

SUDMT7033L

- Take down the snap ring with pliers.
Take down the 2nd/3rd synchronizer ASSY.
Please don't let the parts in synchronizer ASSY jump out.

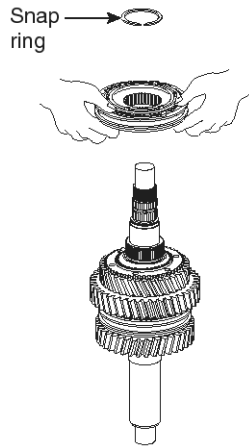

SUDMT7034L

- Dismantle the 2nd gear and clutch gear assembly.
Then take down the needle bearing.

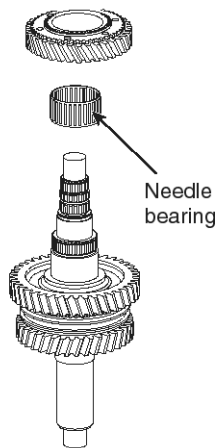

SUDMT7035L

- Turn over the shaft and take down the gear, washer, bearing, sleeve, and hub sec.

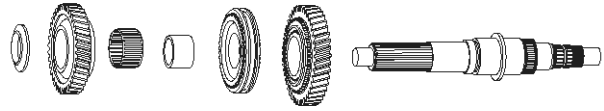

SUDMT7036L

DISASSEMBLY(GEAR SHIFT UPPER)

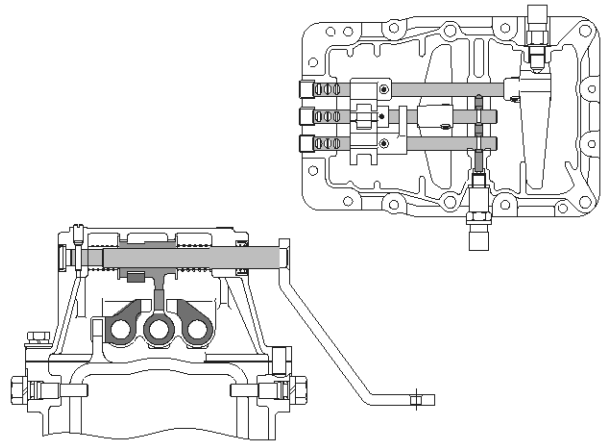

SUDMT7037L

- Turn down neutral switch, reverse switch and air breather.

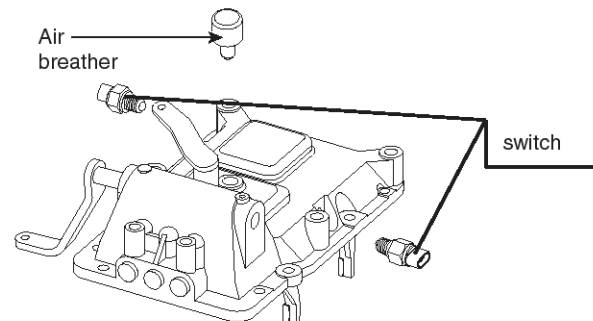

SUDMT7038L

MTC-22

Manual Transmission

2. Turn down the shift fork-1st/REV and shift shaft-1st/REV.

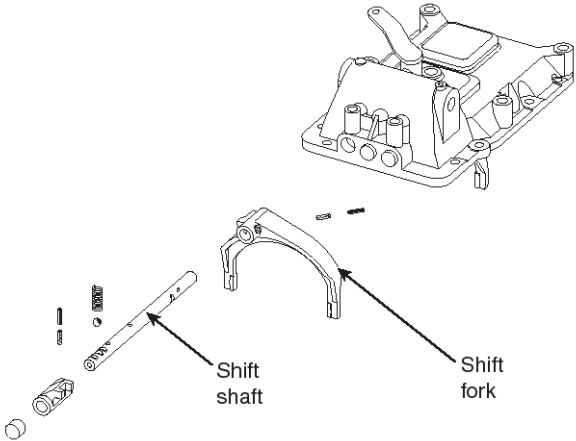

SUDMT7039L

3. Turn down the shift fork-1 and shift shaft.

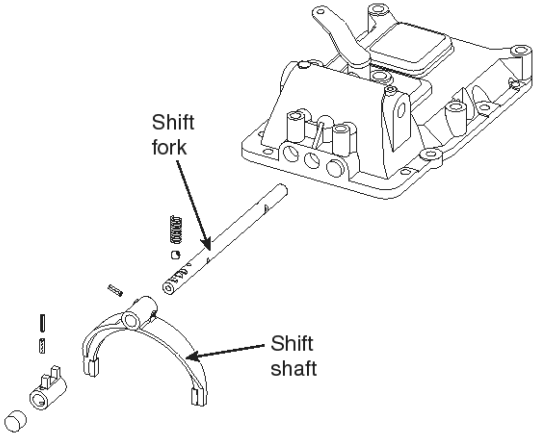

SUDMT7040L

4. Turn down the shift fork and shift shaft.

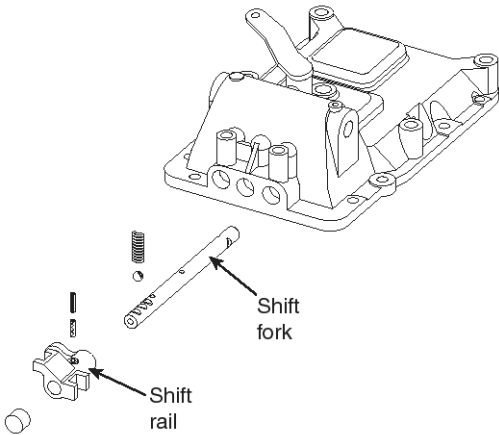

SUDMT7041L

5. Turn down the select lever ASSY

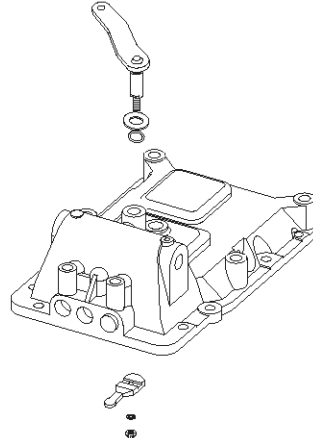

SUDMT7042L

6. Dismantle the shift lever ASSY.

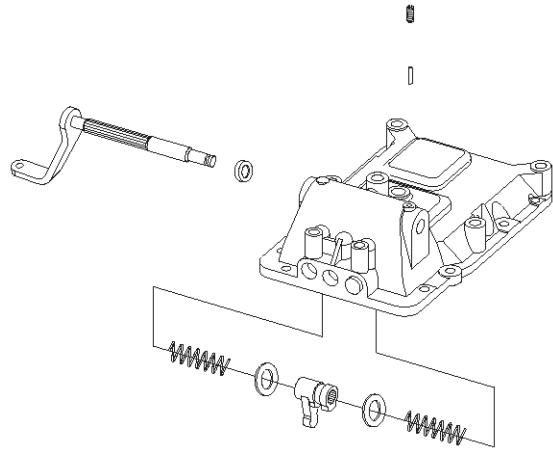

SUDMT7043L

REASSEMBLY

⚠ CAUTION

Before assembling the transmission, one shall assure the interior of T/M housing and other parts have been checked and cleaned completely!

1. apply the sealed pastern (LOCTITE598/587) on the surface of housing.(see fig. A and fig. B)

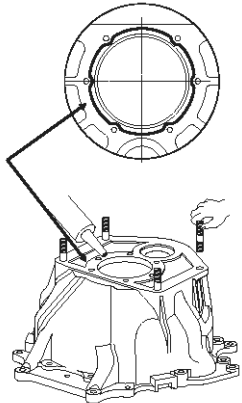

Fig. A

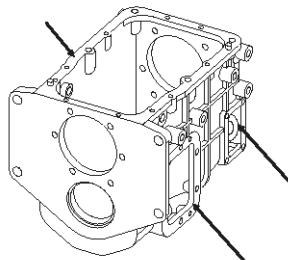

Fig. B

SUDMT7044L

2. When install oil seal, should press it into the case perpendicularity.

⚠ NOTICE

1. A proper pressing tool should be used for mounting of the oil seal. An inappropriate tool may cause damaged oil seal.(See Fig. C)
2. The oil seal may be prone to damaged and should be placed in the package before assembling.
3. When the parts which with spline shaft pass through the oil seal, the burring on the parts should be get rid of. The shafts should be rotated slowly so that they pass through in parallel and the shaft oil seal will not be damaged.

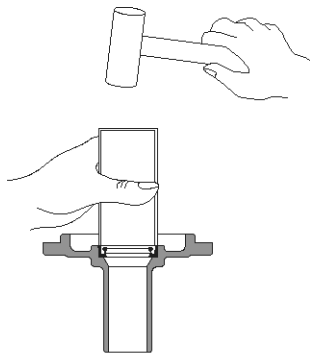
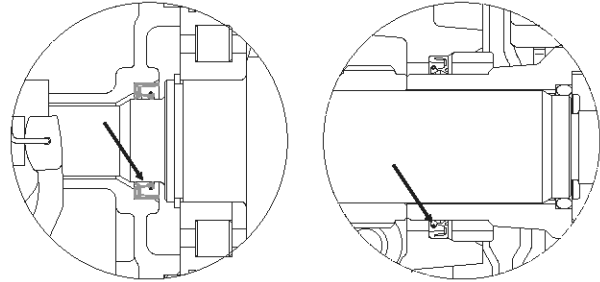

Fig. C

SUDMT7045L

3. Apply lubricating grease onto the lip of oil seal when assembling the T/M.



SUDMT7046L

4. Before assembling, gear oil shall be applied on the side face of the gear, the interface of the gasket and the rotation engagement surface of the bearing and other parts.(in tropical zone, applying SAE 90 (GL-4) ; in temperate zone or Frigid zone, applying SAE 80W-90 (GL-4))

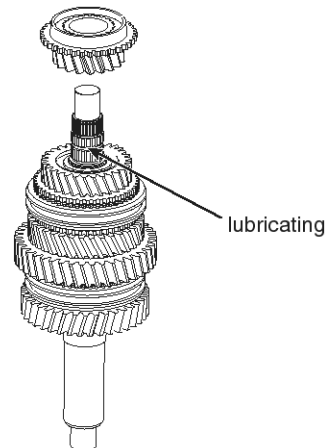

SUDMT7047L

5. The method to adjust parking brake:

- 1) Take down the baffle.

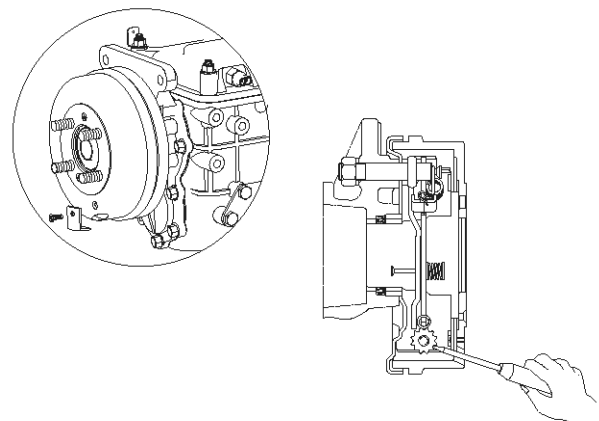

SUDMT7048L

- 2) Put the tool into the hole.
- 3) Dial the adjusting wheel to adjust the clearance between parking drum and shoe plate.
6. The lock nut shall be knocked with the head of shaft after being screwed, prevent from loosening.

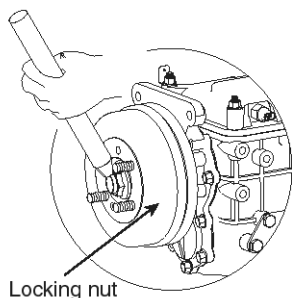
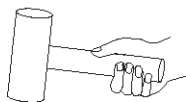

SUDMT7049L

7. Lubricating enough gear oil into transmission.

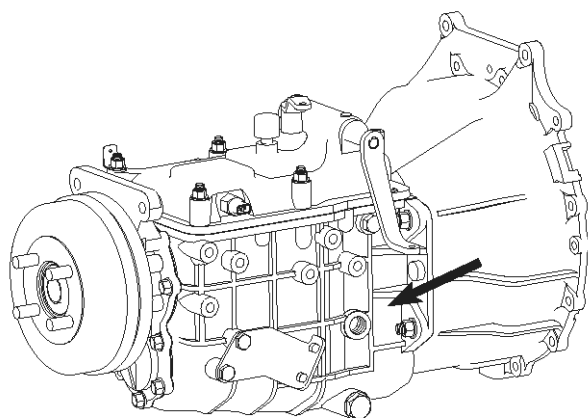

SUDMT7050L