

Manual Transmission (T060S5)

General

Specification	MT - 2
General Safety Information	MT - 6
Inspection	MT - 8
Description.....	MT - 11
Troubleshooting and test.....	MT - 15
Service Special Tool	MT - 17

Manual Transmission

Components	MT - 24
Removal	MT - 26
Installation	MT - 28
Gear Shift Upper	
Components	MT - 30
Service Procedure	MT - 31
Transmission Assembly	
Disassembly	MT - 33
Installation	MT - 34
Pinion Drive	
Components	MT - 37
Disassembly	MT - 37
Assembly	MT - 37
Main Shaft	
Components	MT - 38
Disassembly	MT - 40
Reassembly	MT - 42
Counter Shaft	
Components	MT - 47
Disassembly	MT - 48
Assembly	MT - 48
Shift Rail and Shift Fork	
Components	MT - 49
Disassembly	MT - 50
Assembly	MT - 50

Manual Transmission Control System

Gear Shifter Lever	
Components	MT - 52
Service Procedure	MT - 53
Shift Cable and Select Cable Assembly	
Components	MT - 55
Removal	MT - 56
Installation	MT - 56

General

SPECIFICATION

Type		Specification	
Model		T060S5	
Torque		60 kgf.m	
Gear ratio	1st gear	5.810	
	2nd gear	3.281	
	3rd gear	1.787	
	4th gear	1.000	
	5th gear	0.705	
	Reverse gear	5.294	
Gear oil		API GL-4, 75W85	
Oil quantity		4.5 L (W/O PTO), 4.9 L (With PTO)	
Gear range		End play(mm)	Backlash(mm)
	1st gear	0.14~0.37	0.065~0.236
	2nd gear	0.14~0.37	0.06~0.217
	3rd gear	0.11~0.33	0.064~0.212
	4th gear	-	0.063~0.215
	5th gear	0.27~0.43	0.069~0.207
	Reverse gear (reverse idler ~ main shaft idler)	0.22~0.44	0.063~0.230
	Reverse gear (counter shaft idler ~ reverse idler)	0.3~0.45	0.077~0.263

TIGHTENING TORQUE

The capscrew, plug, and nut should be tightened to the specified torque to prevent oil leakage and loosening of components. Those parts should be also tightened to the specified torque to maintain a good transmission's performance for a long time. In addition, always apply the sealant to the areas indicated.

⚠ CAUTION

Comply with the specified torque when assembling.

WITHOUT PTO

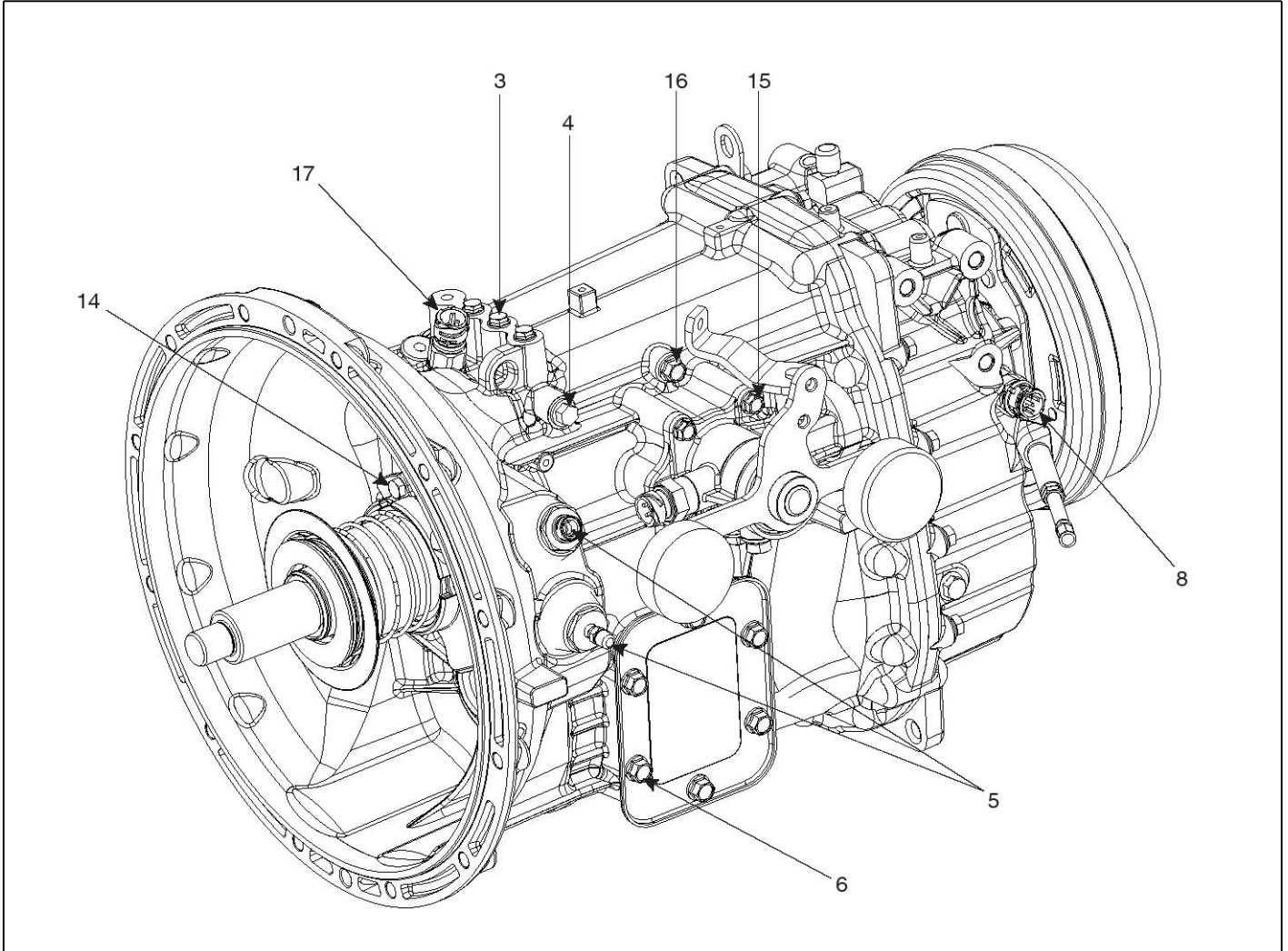

MT-4

Manual Transmission

WITH PTO

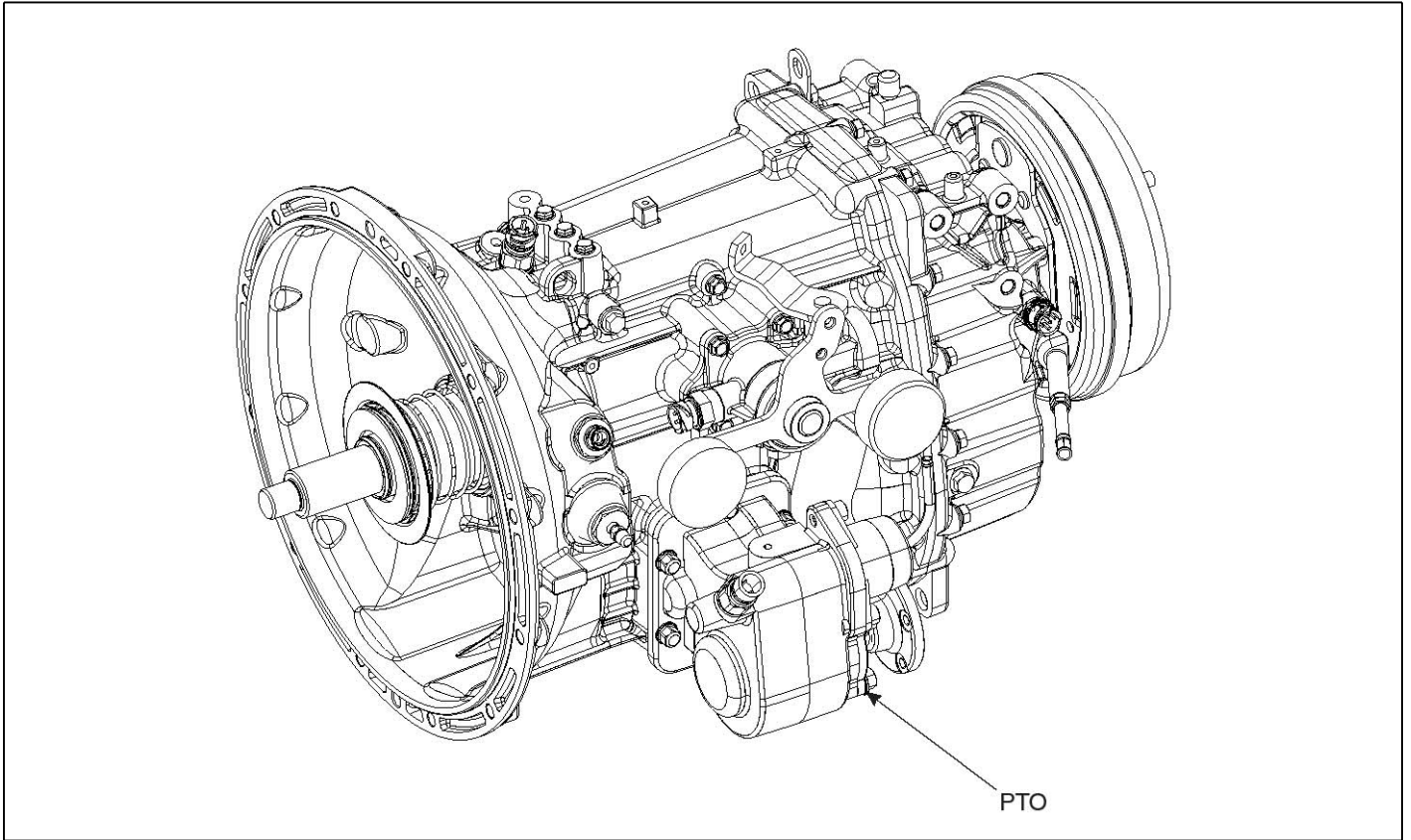

SUDMT9002D

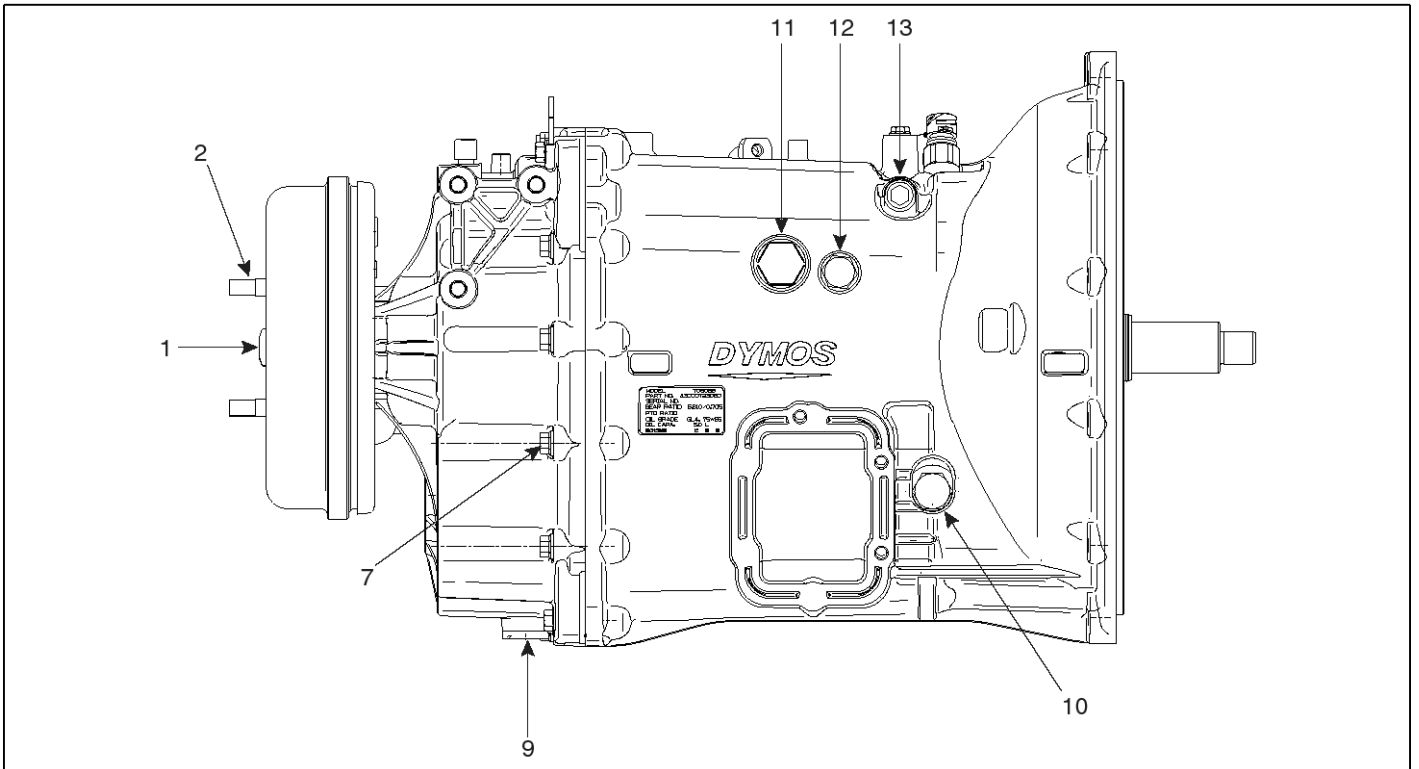

SUDMT9003D

No.	Name	Tightening torque kgf.m (Nm, lb.ft)	Sealant
1	Output shaft bolt	24~28 (235.3~274.6, 173.6~202.5)	
2	Parking brake bolt	5.4~6.2 (53~60.8, 39.1~44.8)	
3	Flange bolt	2.6~3 (25.5~29.4, 18.8~21.7)	
4	Screw plug	3.5~4.1 (34.3~40.2, 25.3~29.7)	Loctite 5060
5	CSC connection	7.2~8.4 (70.6~82.4, 52.1~60.8)	
6	PTO cover bolt	4.5~5.2 (44.1~51, 32.5~37.6)	Loctite 5060
7	Housing assembling bolt	5.4~6.2 (53~60.8, 39.1~44.8)	Loctite 5060
8	Speedometer sensor	4.6~5.4 (45.1~53, 33.3~39.1)	
9	Oil drain plug	7.2~8.4 (70.6~82.4, 52.1~60.8)	
10	Oil filler plug	7.2~8.4 (70.6~82.4, 52.1~60.8)	Loctite 5060
11	Control support bolt	5.4~6.2 (53~60.8, 39.1~44.8)	
12	4th/5th fork pin bolt	5.4~6.2 (53~60.8, 39.1~44.8)	
13	Screw plug	3.5~4.1 (34.3~40.2, 25.3~29.7)	Loctite 5060
14	CSC mounting bolt	2.1~2.5 (20.6~24.5, 15.2~18.1)	
15	Control assembly mounting bolt	2.1~2.5 (20.6~24.5, 15.2~18.1)	Loctite 5060
16	Guide pin seal bolt	3.5~4.1 (34.3~40.2, 25.3~29.7)	
17	Back lamp switch	4.6~5.4 (45.1~53, 33.3~39.1)	

GENERAL SAFETY INFORMATION

PRECAUTIONS WHEN ASSEMBLING AND DISASSEMBLING

CAUTION

When assembling the transmission, apply the same transmission lubricant oil to gear bearings, needle bearings, non-sealed bearings and all other parts under friction conditions.

Apply the same transmission lubricant oil in order to prevent damage to transmission parts during initial gears movement.

CLEANING AND HANDLING

Immerse them into a solvent bath (kerosene, for instance) to completely clean the parts. Wash them by moving every part slowly up and down until all the old lubricant and foreign material have been dissolved.

CAUTION

A special care must be taken to avoid skin rasher, fire hazard and vapor inhalation when using solvents.

NON-SEALED BEARINGS

Immerse the bearings in clean solvent. Move them slowly up and down to remove the deposits. Dry the bearings with moisture free compressed air. In this way, dry all the bearings after cleaning them.

CAUTION

Never drive the air jet directly to bearing not to rotate it in high speed. That can cause damage to the bearing.

SYNCHRONIZER ASSEMBLY

A special care should be taken when handling the synchronizer assemblies. Either drops or bumps when disassembling or assembling may lock them.

HOUSING

Clean thoroughly the inside and outside of cases, covers, etc. Clean cast parts in mild alkaline solution container (a 7% soluble degreasing oil solution is recommended). Keep the parts in the solution container until they become completely clean. The parts cleaned in alkaline solutions should be rinsed with clean water to remove any alkaline trace after cleaning process.

Do not drop or bump.

INSPECTION

A thorough and careful inspection of every part may extend the life of transmission.

The replacement of parts showing either wear or damage may avoid future foreseen failures.

GEARS, SHAFTS, AND SYNCHRONIZER ASSEMBLIES

Check the parts whenever magna-flux is available.

Check carefully gear teeth for wear, pitting, chipping and cracks. Replace with a new one if any damage is found when checking.

Check shafts for warping and excessive wear or damaged splines.

CASE AND COVER

Make sure that cases and covers are completely clean and that mounting surfaces and bearing bores are free from chips or burrs.

Check carefully individual parts for cracks or excessive wear. And check them for any other condition that may cause oil leak or a future failure.

NEEDLE BEARING

Check carefully every needle roller for wear, pitting or cracked areas to determine whether they are suitable for reuse or should be replaced. After inspection, dip the needle bearings in an oil container and then wrap them in a lint free cloth or paper, so as to protect them until they are to be reassembled.

OIL SEALS AND SNAP RINGS

Replace with a new one if damages to any oil seal and snap ring are found during maintenance. The replacement of oil seal and snap ring in time can prevent damage to the parts of transmission beforehand.

An oil leakage through a worn seal may result in failures of other more expensive components of the transmission.

The sealing elements should be handled carefully, particularly during assembly.

Cuts, scratches or rolled up seal lips decrease the sealing efficiency.

⚠ CAUTION

The snap rings should be assembled in the proper position due to the angle of their opening ends. Make the side with shorter opening face outwards to facilitate the installation with pliers.

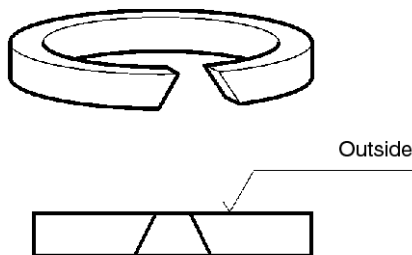

SUDMTA9001L

PARTS REPLACEMENT

Use only genuine parts when replacing parts. The use of genuine parts can extend the life of transmission.

INSPECTION

Transmission Oil Check

Frequent replacement of transmission oil can prevent bearings damage, rings wear. The small metallic particles may be accumulated and cause damage to various parts when the transmission oil is used for a long time without changing it. The transmission oil will be changed by the chemical action due to rapid change of oil temperature when the transmission is also used.

Recommended Oil :

- SAE 75W85 API GL4
-

Oil Maintenance Intervals

1. When driving on highway
 - Replace the transmission oil after driving initial 100,000 km.
 - Check the transmission oil for level and leak every 50,000 km.
 - Replace the transmission oil every 150,000 km.
2. When driving on general roads
 - Replace the transmission oil after driving initial 100,000 km.
 - Check the transmission oil for level and leak every 50,000 km.
 - Replace the transmission oil every 150,000 km.

Transmission Oil Drain

Drain the transmission oil when it is warm. Drain the transmission oil after removing the magnetic drain plug. Clean the drain plug before refilling with the recommended transmission oil.

Refilling Transmission

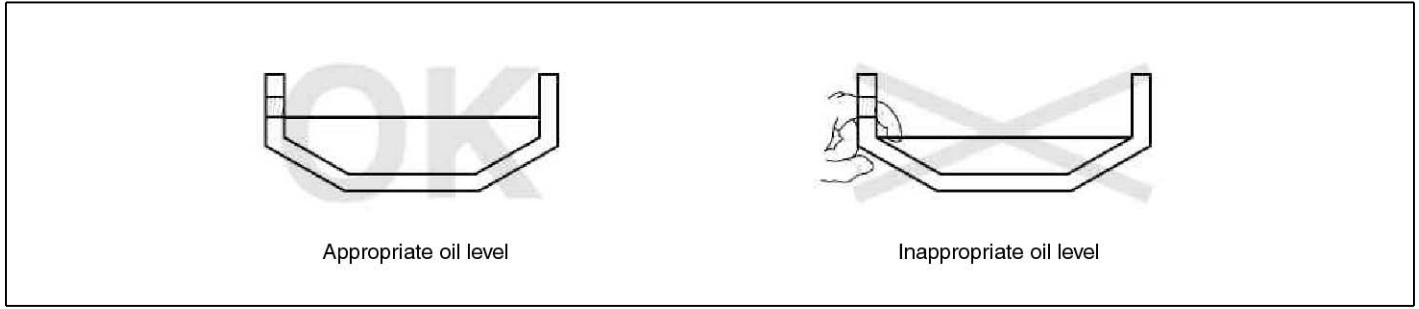

SUDMTA9002L

Clean the case around transmission oil filler plug and add transmission oil to the proper level after removing the oil filler plug.

The amount to refill transmission oil differs according to the gradient of the transmission. Therefore stop the vehicle on a flat road surface and refill the transmission oil.

Do not add the transmission oil above the proper level because the oil can leak through the front bearing cover, control cover or shift lever housing.

Transmission oil amount :

- 4.5 L (Without PTO)
- 4.9 L (With PTO)

NOTICE

The amount to refill may differ according to the gradient of engine or transmission. Always add the transmission oil to the proper level.

Oil Level Check

Clean the transmission oil filler plug when checking the oil level and add it to the proper level.

CAUTION

Do not mix oils of different types and brands, as they might cause damage to the transmission parts.

Gear Shift Lever Pattern

It has five forward speeds and one reverse speed and the gear shift lever pattern is illustrated below.

The reverse gear shifting interlocking system prevents the accidental shifting from 5th speed gear to reverse speed gear.

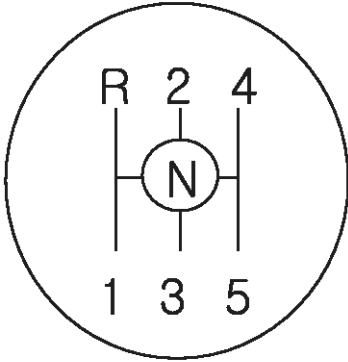

SUDMT9004D

NOTICE

Notes while driving

- Always use the clutch while shifting the gears. Otherwise there may cause damage to the synchronizer assembly.
- Use the proper shift gear when driving away from a stop depending on the vehicle's load and road conditions.
- Never slam or jerk the gear shift lever to complete gear engagement.
- Never take the vehicle out of gear and coast down a hill.

Precautions For Seized Taper Roller Bearing (Pocket bearing)

CAUTION

Warm up for more than several minutes when replacing the transmission oil or disassembling and reassembling the transmission.

1. There is a possibility that the pocket bearing may be damaged initially if the transmission is a brand new product.
2. Care must be taken not to depress the accelerator pedal with 1,200 rpm or higher for more than two minutes with the shift lever neutral until the driving distance covered right after reassembling the transmission is within 100~200 km. Because the pocket bearing may be damaged.
3. Depress the clutch pedal and hold it if you want to accelerate 1,200 rpm or higher with the shift lever neutral.
4. There is little possibility that the transmission may be damaged when the driving distance covered is above 100~200 km.

Description

The transmission should transmit the output and torque of engine to the drive line of vehicle sufficiently. It is very helpful if you know the torque power flow when repairing the transmission.

1st Speed Gear, 2nd Speed Gear, 3rd Speed Gear, 5th Speed gear

1. The torque from the engine is transmitted to the pinion drive of transmission.
2. The torque is transmitted from the pinion drive to the countershaft through the drive gear. In this manner, the pinion drive is always driven together with the countershaft.
3. The torque is transmitted to all the mainshaft gears assembled to the bearing in the countershaft.

These gears rotates freely unless one of gears is shifted.

4. After the torque is transmitted from the mainshaft gear to the clutch's serrations of the synchronizer assembly when the gear is shifted, it is transmitted to the synchronizer hub and driven with the mainshaft. The torque is transmitted from the mainshaft to the drive line through the output yoke.

1st speed gear

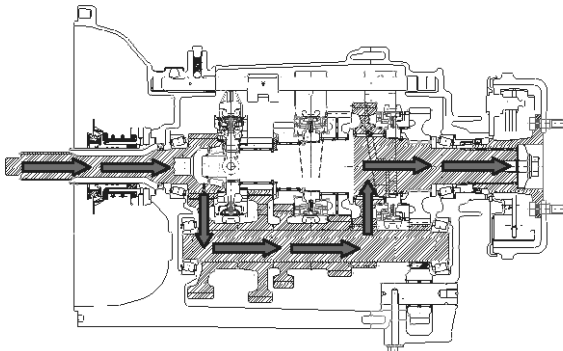

SUDMTA9003L

2nd speed gear

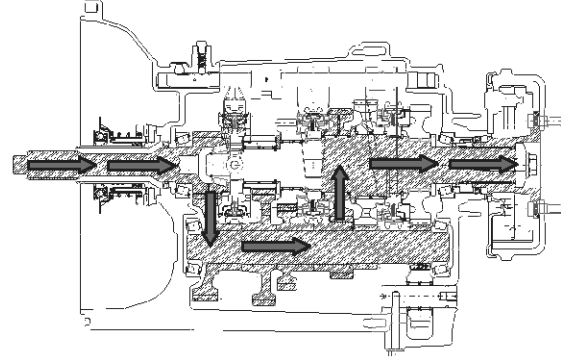

SUDMTA9004L

3rd speed gear

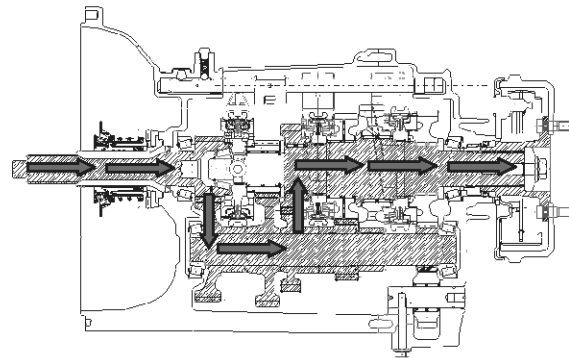

SUDMTA9005L

5th speed gear

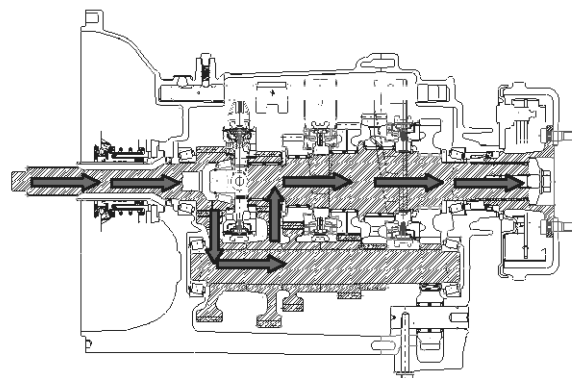

SUDMTA9006L

MT-12

Manual Transmission

4th Speed Gear

The 4th speed gear is called by direct speed gear. The torque occurs in the drive pinion and is directly transmitted to the mainshaft although the countershaft moves.

The torque is directly connected to the mainshaft and transmitted to the pinion drive clutch serrations linked to the 4th speed gear synchronizer hub.

The noise is very little since the direct connections are made from one shaft to other one without any other gear load in 4th speed gear.

4th speed gear

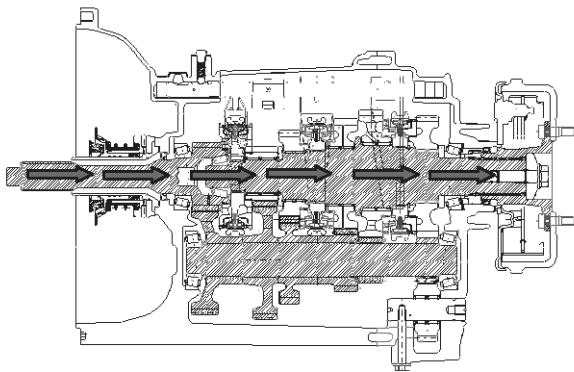

SUDMTA9007L

Reverse Speed Gear

When the reverse speed gear is shifted into, the torque is transmitted from the countershaft to the reverse idler gear and changes the rotation direction. The torque is transmitted from the reverse idler gear to the mainshaft reverse speed gear.

Reverse speed gear

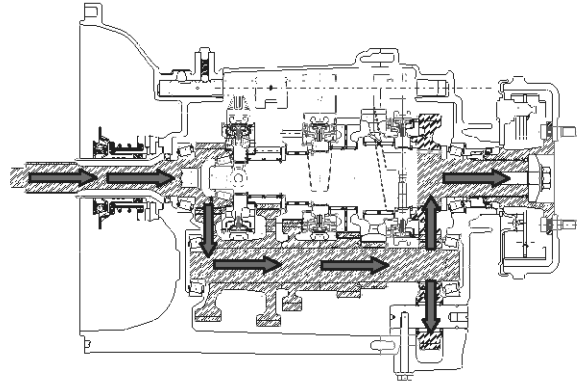

SUDMTA9008L

Applying Sealant

The sealant should be applied to the proper positions for the correct reassembly and the prevention of leak.

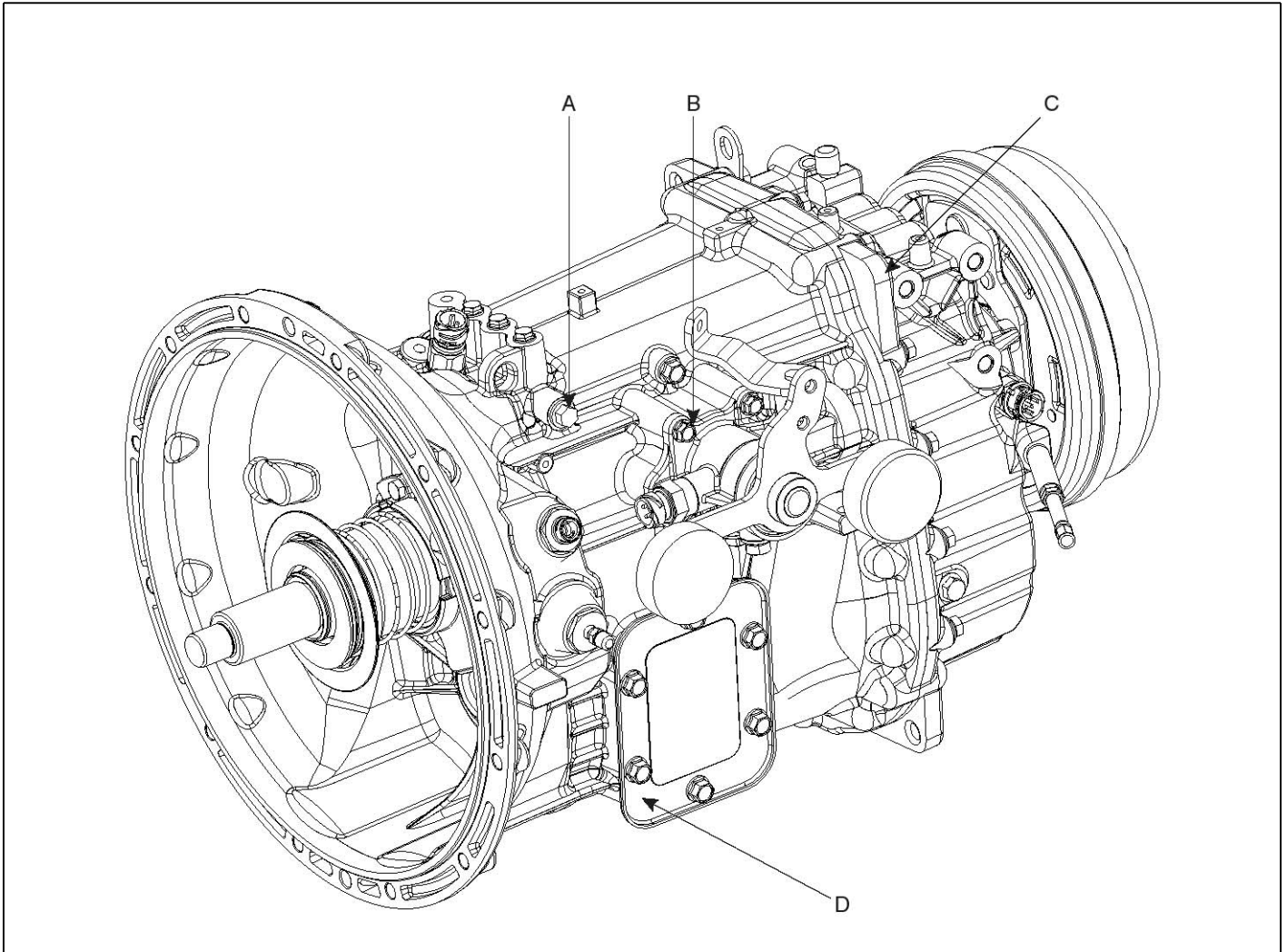

SUDMT9011D

A : Apply Loctite 5060 to the screw plug.

B : Apply Loctite 5060 to the housing mounting surface.

C : Apply Loctite 5060 to the front and rear housing mounting surface.

D : Apply Loctite 5060 to the PTO cover mounting surface.

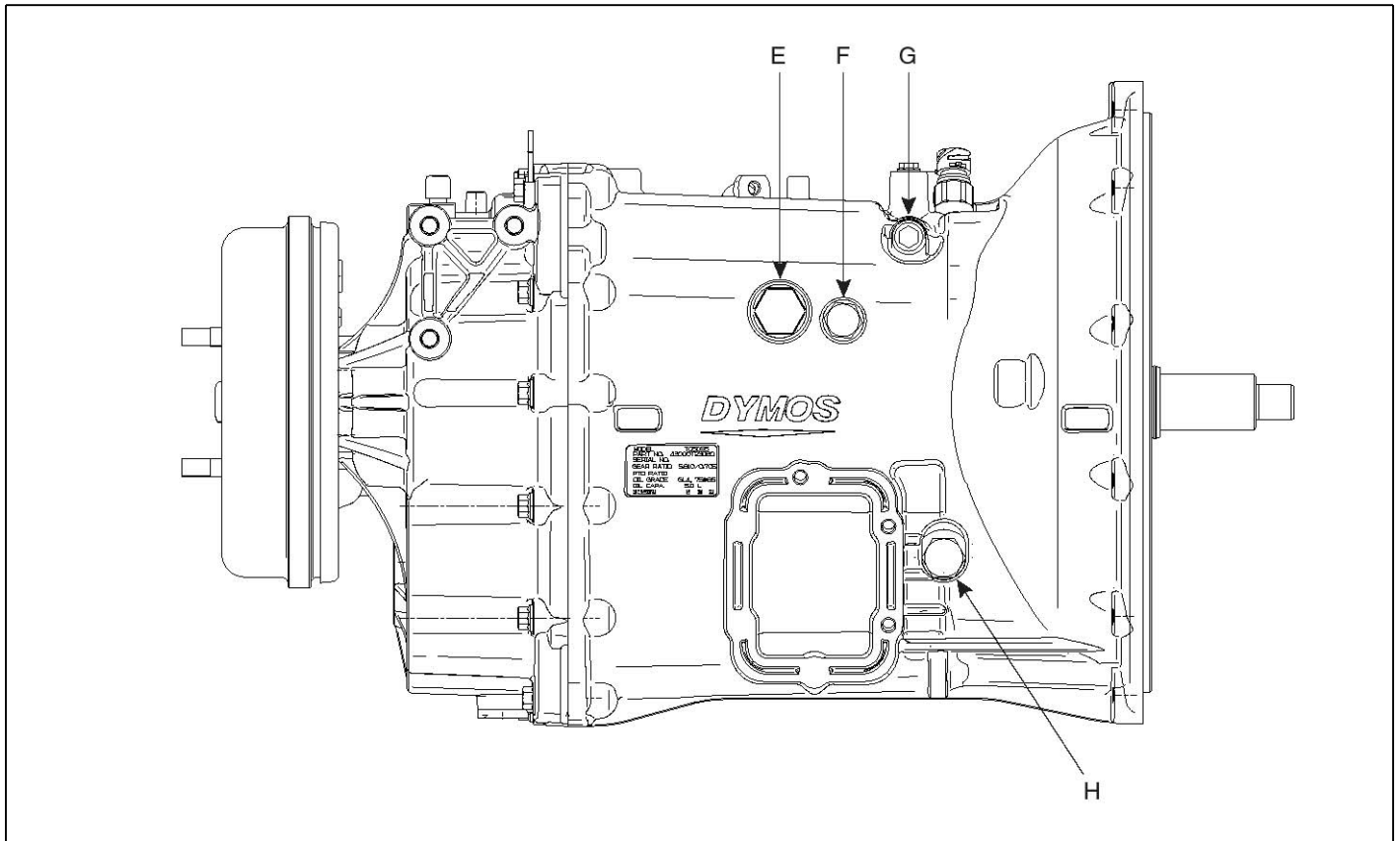

SUDMT9012D

E : Apply Loctite 5060 to the control support bolt.

F : Apply Loctite 5060 to the 4th/5th speed gear fork pin bolt.

G : Apply Loctite 5060 to the screw plug.

H : Apply Loctite 5060 to the filler plug.

TROUBLESHOOTING AND TEST

Problem	Probable cause	Remedy
Transmission noise when in neutral	Incorrect idle speed adjustment	Adjust idle speed
	Improper or damaged clutch disc	Replace disc
	Loose or damaged engine or transmission mounting	Replace and/or tighten mounting
	Worn or damaged yoke	Replace yoke
	Warped or unbalanced drive shaft	Repair or replace drive shaft
	Low lubricant level	Fill with recommended oil to the proper level
	Contaminated lubricant	Drain and clean transmission and refill with recommended oil
	Worn or damaged gears and/or bearings	Replace damaged parts
	Misalignment due to loose tightening capscrews	Retighten capscrews
Transmission noise from shifted gears	Improper or damaged clutch disc	Replace disc
	Low lubricant level	Fill with recommended oil to the proper level
	Worn or damaged flywheel bushing or bearing	Replace damaged parts
	Vibration from other vehicle components (drive shaft, mounts, yoke)	Verify and repair as per vehicle's manual
	Misalignment between engine and transmission	Realign
	Worn or damaged gears and/or bearings	Replace damaged parts
	Warped main shaft or countershaft	Replace warped shaft
Hard shifting	Malfunction of clutch (not releasing)	Check and adjust clutch drive system
	Wrong adjustment of clutch pedal	Adjust pedal stroke
	Worn or damaged flywheel bushing or bearing	Replace damaged parts
	Improper, contaminated lubricant	Drain, clean, and refill with recommended oil
	Low lubricant level	Fill with recommended oil to the proper level
	Worn or damaged gear shift lever components	Replace damaged parts
	Worn or damaged synchronizer rings	Replace rings
	Excessively worn or damaged synchronizer assemblies (keys, sleeve or hub)	Replace synchronizer assemblies
	Improper adjustment of synchronizer assemblies sleeve or hub	Readjust synchronizer assemblies
	Worn or damaged shift system components (yokes, nylon pads, bars, shift blocks)	Replace damaged parts
Improper end play of main shaft or countershaft	Adjust end play	

Problem	Probable cause	Remedy
Gear shift rubbing	Malfunction of clutch (not releasing)	Check and adjust clutch drive system
	Wrong adjustment of clutch pedal stroke	Adjust pedal stroke
	Malfunction of clutch drive system	Check and adjust system
	Worn or damaged flywheel bushing or bearing	Replace damaged parts
	Incorrect idle speed adjustment	Adjust idle speed
	Worn or damaged synchronizer rings	Replace rings
	Worn or damaged gear clutching teeth	Replace gear
	Worn shift yokes nylon pads	Replace nylon pads
Transmission slips out of gear	Misalignment between engine and transmission	Realign
	Incomplete gear shifting	Shift gear properly
	Excessive vibration on gear shift lever (due to loose or damaged engine or transmission mountings)	Replace and/or tighten mountings
	Gear shift lever console out of position, forcing the lever	Adjust console
	Worn or damaged synchronizer assemblies	Replace synchronizer assemblies
	Excessive axial clearance on main shaft gears	Adjust clearance
	Worn or damaged clutching gear teeth	Replace gear
	Worn or damaged shift system (gear shifting lever housing, yokes, bars, etc.)	Replace damaged parts
Oil leak proper level	Excessive oil level	Correct to proper level
	Clogged breather	Check and unclog breather
	Worn or damaged oil seals	Replace damaged seals
	Housing capscrews not properly tightened or lack of sealant	Reassemble with proper sealant and tighten to the specified torque
	Cracked housing or covers	Replace or repair damaged parts
	Warped or damaged mounting surfaces of housings and covers	Replace or repair damaged parts
Defective bearings	Low lubricant level	Fill with recommended oil to the proper level
	Contaminated or not recommended lubricant	Drain and clean transmission and refill with recommended oil
	Improper assembly of transmission components	Reassemble transmission instructions on this manual
	Improper end play of main shaft or countershaft	Adjust end play
	Bearings were not lubricated prior to assembly	Replace/reassemble damaged parts
Double shifting	Double gear shifting interlock system is assembled improperly	Reassemble system

SERVICE SPECIAL TOOL

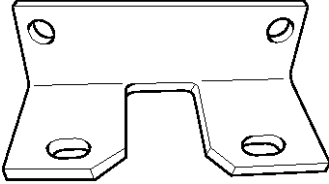
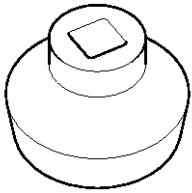
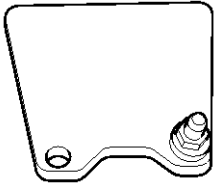
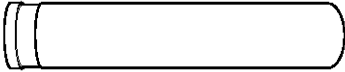
Tool no.	Shape	Use
4405/1	 <p data-bbox="616 629 738 651">SUDMT9013D</p>	Install the output yoke to output flange.
4405/2	 <p data-bbox="616 987 738 1010">SUDMT9014D</p>	Socket plug
4405/3	 <p data-bbox="616 1346 738 1368">SUDMT9015D</p>	Base for dial indicator
4405/4	 <p data-bbox="616 1704 738 1727">SUDMT9016D</p>	Installation of pinion drive bearing cone

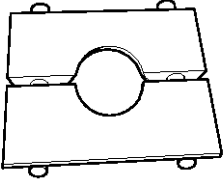
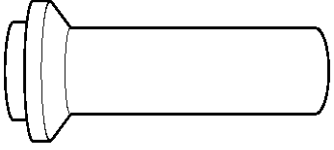
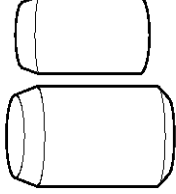
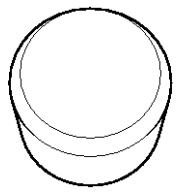
Tool no.	Shape	Use
4405/5	 <p data-bbox="619 586 746 609">SUDMT9017D</p>	Pinion drive bearing puller
4405/6	 <p data-bbox="619 945 746 967">SUDMT9018D</p>	Installation of rear oil seal
4405/7	 <p data-bbox="619 1303 746 1326">SUDMT9019D</p>	Installation of bearing puller
4405/8	 <p data-bbox="619 1662 746 1684">SUDMT9020D</p>	When reassembling countershaft bearing cone

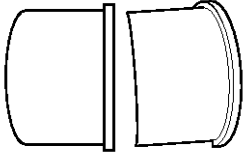
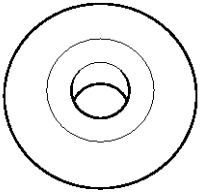
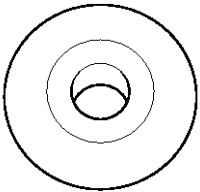
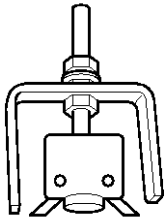
Tool no.	Shape	Use
4405/9	 <p data-bbox="616 584 740 607">SUDMT9021D</p>	Mainshaft pilot bearing puller
4405/10	 <p data-bbox="616 943 740 965">SUDMT9022D</p>	When reassembling mainshaft rear bearing cap
4405/11	 <p data-bbox="616 1301 740 1323">SUDMT9022D</p>	When reassembling countershaft bearing cap
4405/12	 <p data-bbox="616 1659 740 1682">SUDMT9023D</p>	Countershaft bearing cap puller

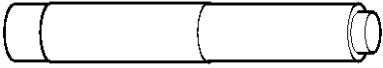
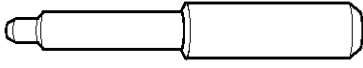
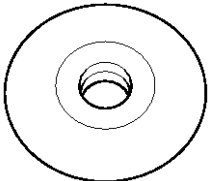
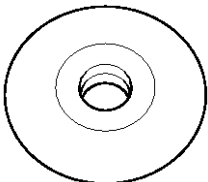
Tool no.	Shape	Use
4405/13	 <p data-bbox="619 584 740 607">SUDMT9024D</p>	Reassembly of shift rail plug
4405/14	 <p data-bbox="619 943 740 965">SUDMT9025D</p>	Reassembly of rear case plug
4405/15	 <p data-bbox="619 1301 740 1323">SUDMT9026D</p>	When reassembling front case bearing cap
4405/16	 <p data-bbox="619 1659 740 1682">SUDMT9026D</p>	When reassembling front case oil seal

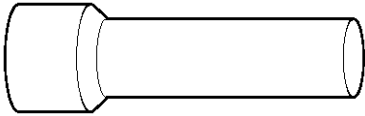
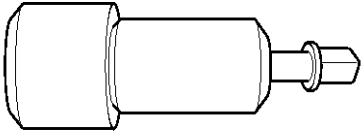
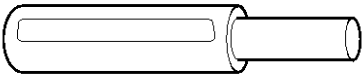
Tool no.	Shape	Use
4405/17	 <p style="text-align: center;">SUDMT9027D</p>	When reassembling mainshaft front bearing cone
4405/18	 <p style="text-align: center;">SUDMT9028D</p>	When reassembling the oil seal of control case
4405/19	 <p style="text-align: center;">SUDMT9029D</p>	Mainshaft rear bearing cone puller
4405/20	 <p style="text-align: center;">SUDMT9030D</p>	Spring pin pusher

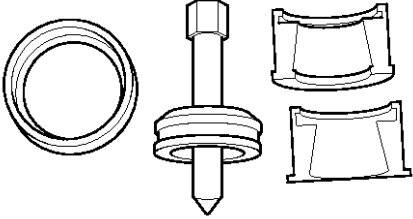
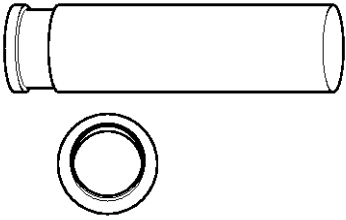
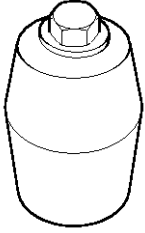
Tool no.	Shape	Use
4405/21	 <p style="text-align: right;">SUDMT9031D</p>	Spring pin extractor
4405/22	 <p style="text-align: right;">SUDMT9032D</p>	Bearing puller
4405/23	 <p style="text-align: right;">SUDMT9033D</p>	When installing input shaft seal
4405/24	 <p style="text-align: right;">SUDMT9034D</p>	When reassembling mainshaft pilot bearing

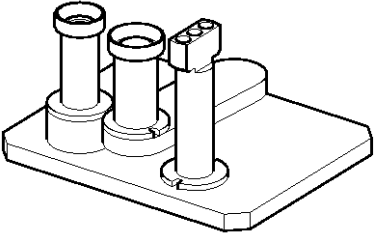
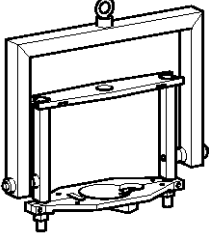
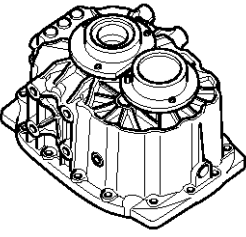
Tool no.	Shape	Use
4405/25	 <p style="text-align: right;">SUDMT9035D</p>	Jig for reassembling gear train and rail assembly
4405/26	 <p style="text-align: right;">SUDMT9036D</p>	<ul style="list-style-type: none"> * Jig for rotating gear train and front housing * To rotate gear train and front housing to 180° for reassembling rear housing * Equipment and tool : Hoist, nut spanner for reassembling
4405/27	 <p style="text-align: right;">SUDMT9037D</p>	<ul style="list-style-type: none"> * Jig for measuring short distance of taper roller bearing * To determine the thickness of shim by measuring distance between taper roller bearings * Measuring device : Depth gauge

Manual Transmission COMPONENTS

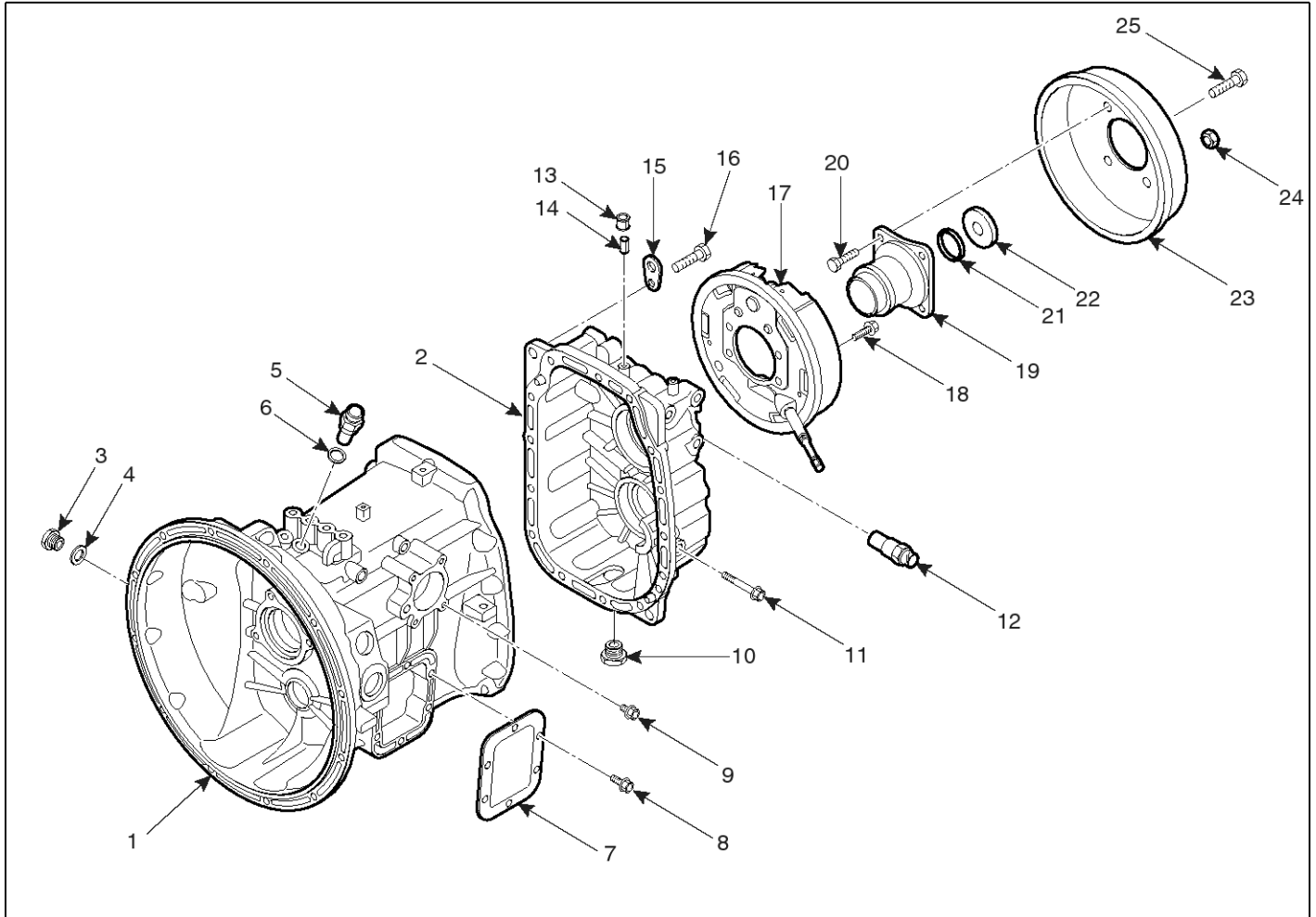

SUDMT9038D

- | | | |
|-------------------------------|---------------------------------|-------------------|
| 1. Front housing | 10. Drain plug | 19. Output flange |
| 2. Rear housing | 11. Reverse idler bolt | 20. Bolt |
| 3. Filler plug | 12. Speedometer sensor | 21. O-ring |
| 4. Gasket | 13. Air breather cap | 22. Output nut |
| 5. Reverse speed light switch | 14. Air breather sleeve | 23. Drum |
| 6. Washer | 15. Mounting bracket | 24. Dust plug |
| 7. PTO cover | 16. Bolt | 25. Bolt |
| 8. Bolt | 17. Parking brake | |
| 9. Screw plug | 18. Parking brake mounting bolt | |

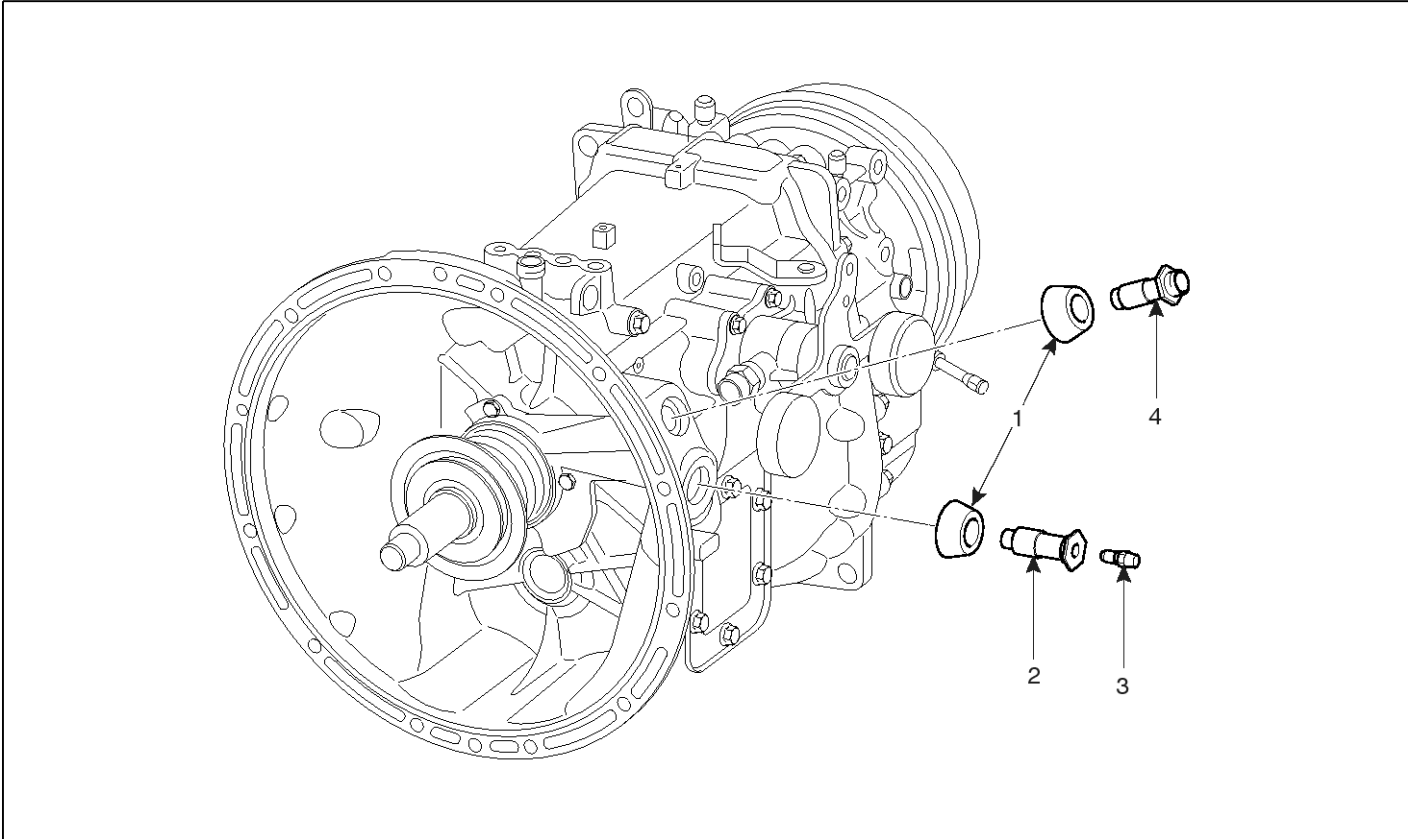

SUDMT9039D

- 1. CSC(concentric slave cylinder) unit
- 2. Connector

- 3. Bleed valve
- 4. Pressure adapter

MT-26

Manual Transmission

REMOVAL

1. Remove the drain plug (A) and drain oil.

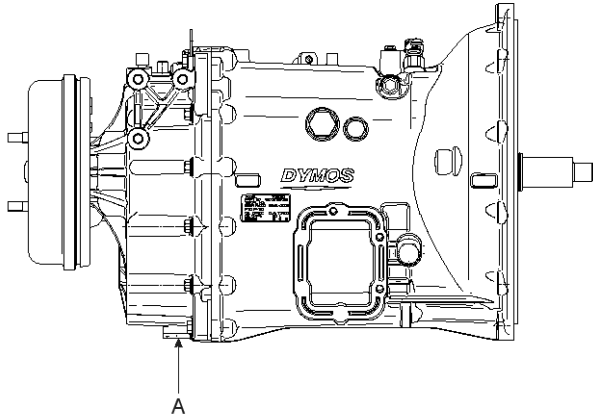

SUDMT9040D

2. Remove the CSC (concentric slave cylinder) connector (A).

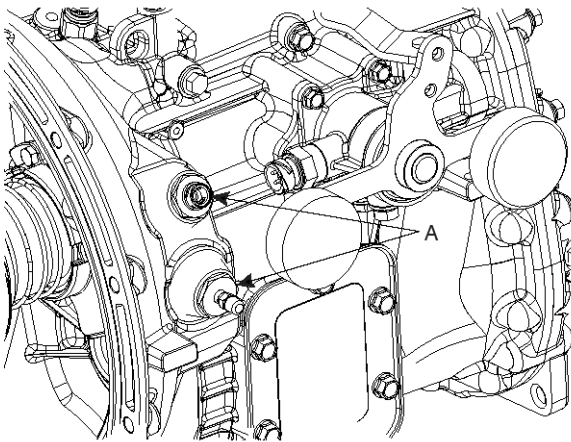

SUDMT9041D

3. Remove the mounting bolt (A) of the CSC and then remove the CSC unit (B).

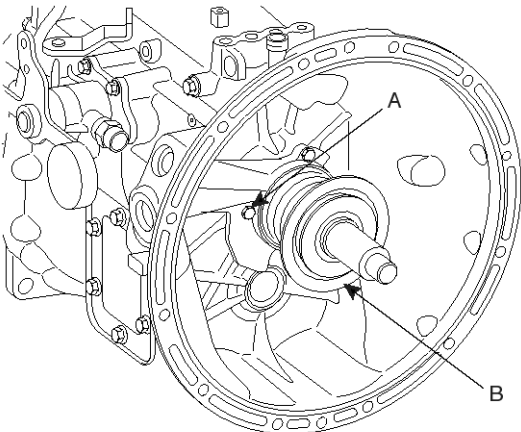

SUDMT9042D

4. Remove the PTO cover(A).

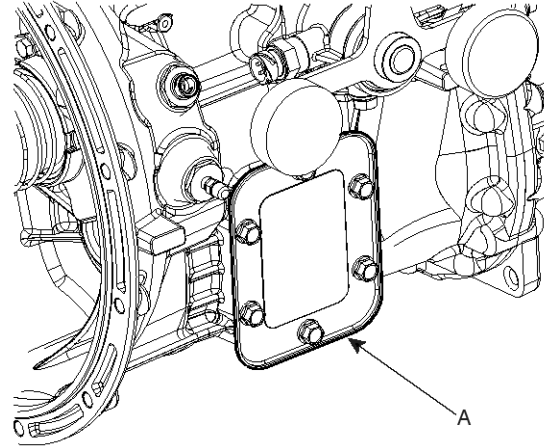

SUDMT9043D

5. Remove the reverse idler mounting bolt (A).

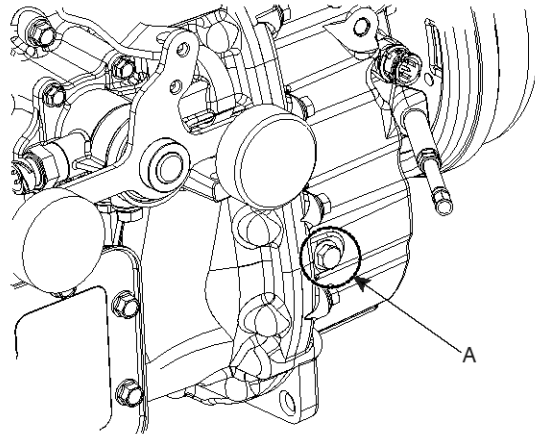

SUDMT9044D

6. Remove the filler plug (A). (Assemble it finally after filling oil.)

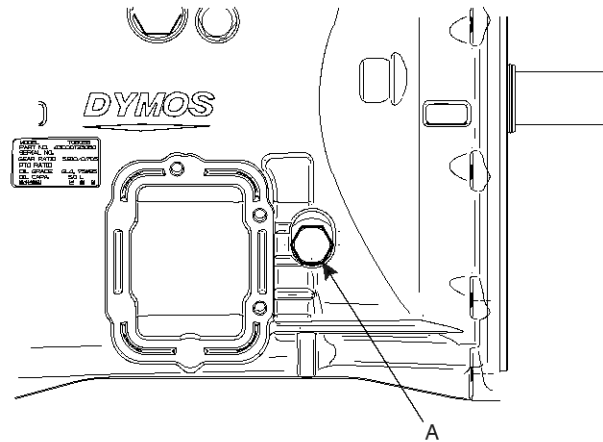

SUDMT9045D

7. Remove the parking brake and drum in the following sequence.

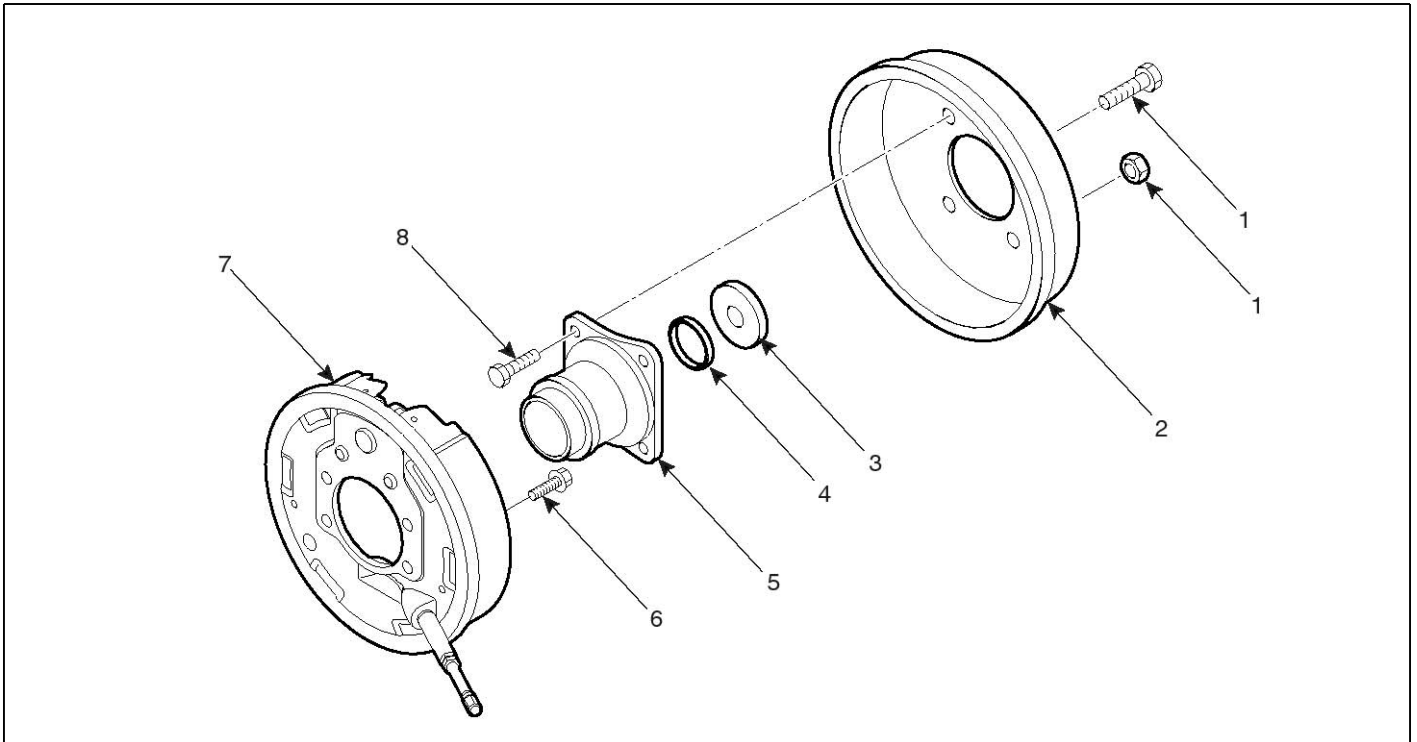

Removal procedure

- 1) Bolt, dust plug (remove if necessary)
 - 2) Drum
 - 3) Output nut
 - 4) O-ring
 - 5) Output flange
 - 6) Parking brake mounting bolt
 - 7) Parking brake
 - 8) Bolt
8. Remove the speedometer sensor (A).

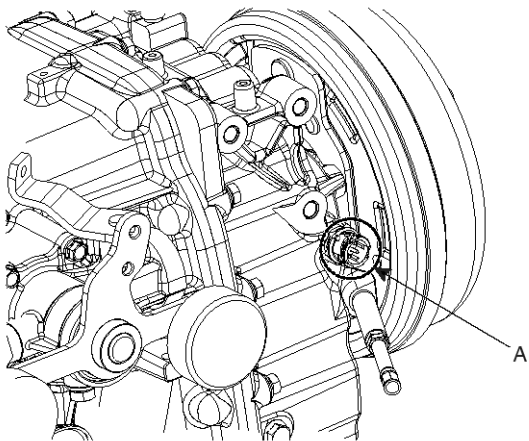

SUDMT9046D

SUDMT9047D

9. Remove the mounting bracket and case assembling bolt (A). (Remove the air breather if necessary.)

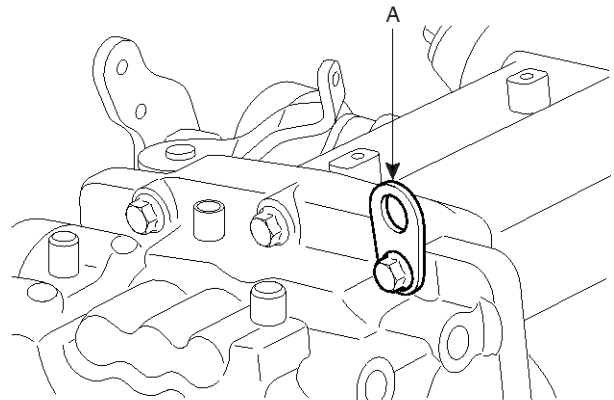

SUDMT9048D

MT-28

Manual Transmission

INSTALLATION

The installation is in the reverse order of removal.

SERVICE POINTS

1. Install the drain plug (A).

Tightening torque : 7.2 ~ 8.4 kgf.m (70.6~82.4 Nm, 52.1~60.8 lb.ft)

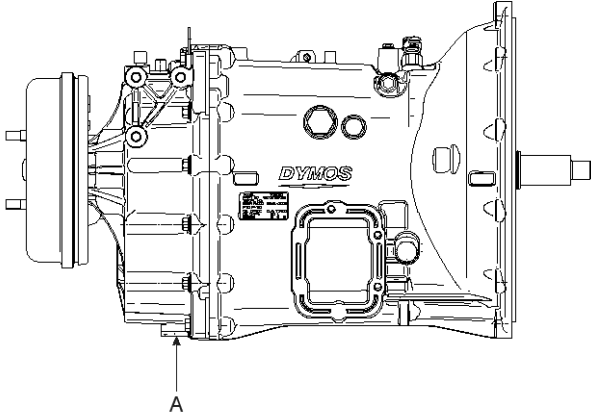

SUDMT9049D

2. Install the PTO cover (A).

Tightening torque : 4.5 ~ 5.2 kgf.m (44.1~51 Nm, 32.5~37.6 lb.ft)

- Apply Loctite 5060 to the mounting surface of PTO cover.

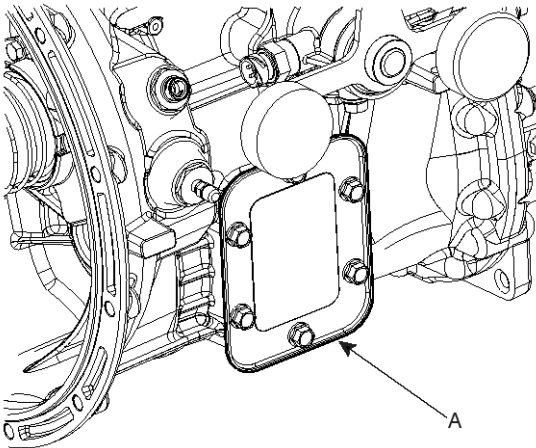

SUDMT9050D

3. Install the reverse idler mounting bolt (A).

Tightening torque : 5.4 ~ 6.2 kgf.m (53~60.8 Nm, 39.1~44.8 lb.ft)

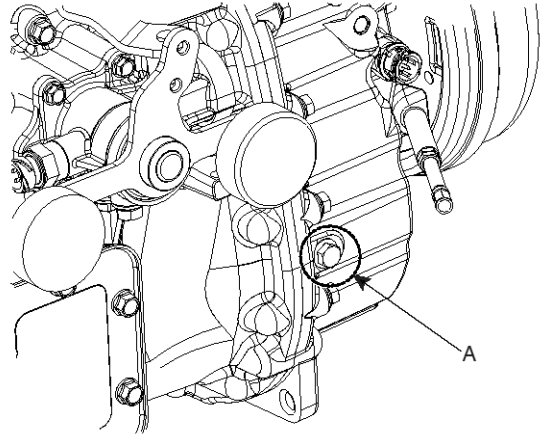

SUDMT9051D

4. Install the filler plug (A).

Tightening torque : 5.4 ~ 6.2 kgf.m (53~60.8 Nm, 39.1~44.8 lb.ft)

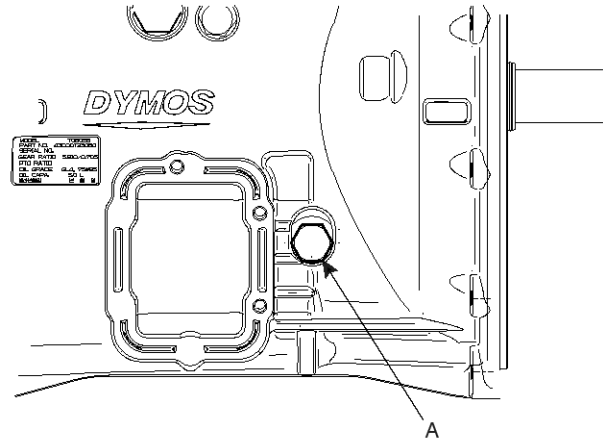

SUDMT9052D

5. Install the parking brake mounting bolt (A).

Tightening torque : 5.4 ~ 6.2 kgf.m (53~60.8 Nm, 39.1~44.8 lb.ft)

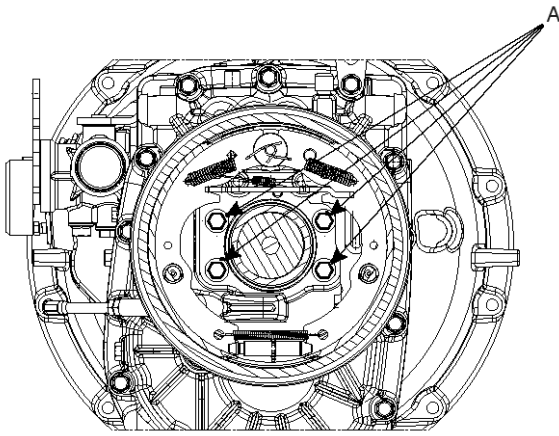

SUDMT9053D

6. Install the output flange nut and bolt.

Tightening torque : 24 ~ 28 kgf.m (235.3~274.3 Nm, 173.6~202.5 lb.ft)

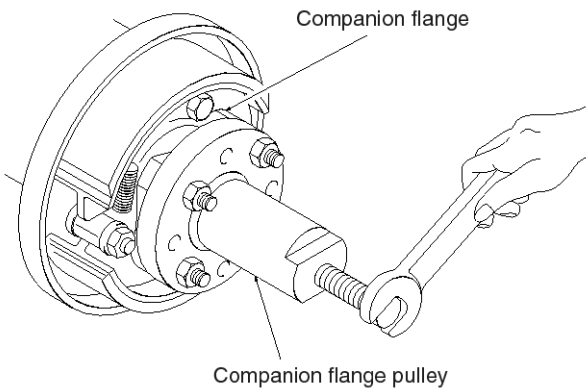

SUDMTA9009L

7. Install the speedometer sensor (A).

Tightening torque : 3.5 ~ 4.1 kgf.m (34.3~40.2 Nm, 25.3~29.7 lb.ft)

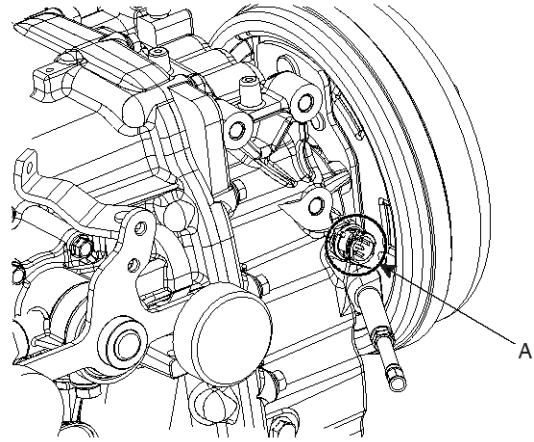

SUDMT9055D

8. Install the mounting bracket and case assembling bolt (A).

Tightening torque : 5.4 ~ 6.2 kgf.m (53~60.8 Nm, 39.1~44.8 lb.ft)

- Apply Loctite 5060 to the mounting surface of the front and rear housing.

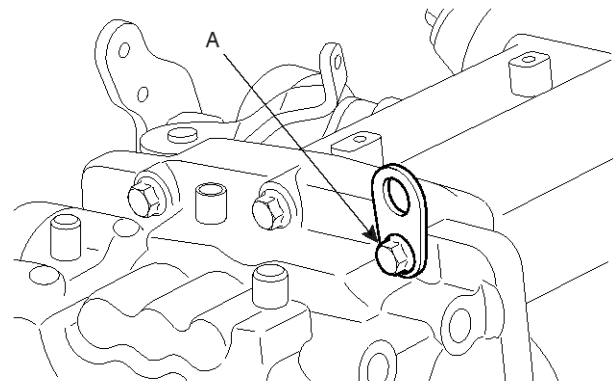

SUDMT9056D

Gear Shift Upper

COMPONENTS

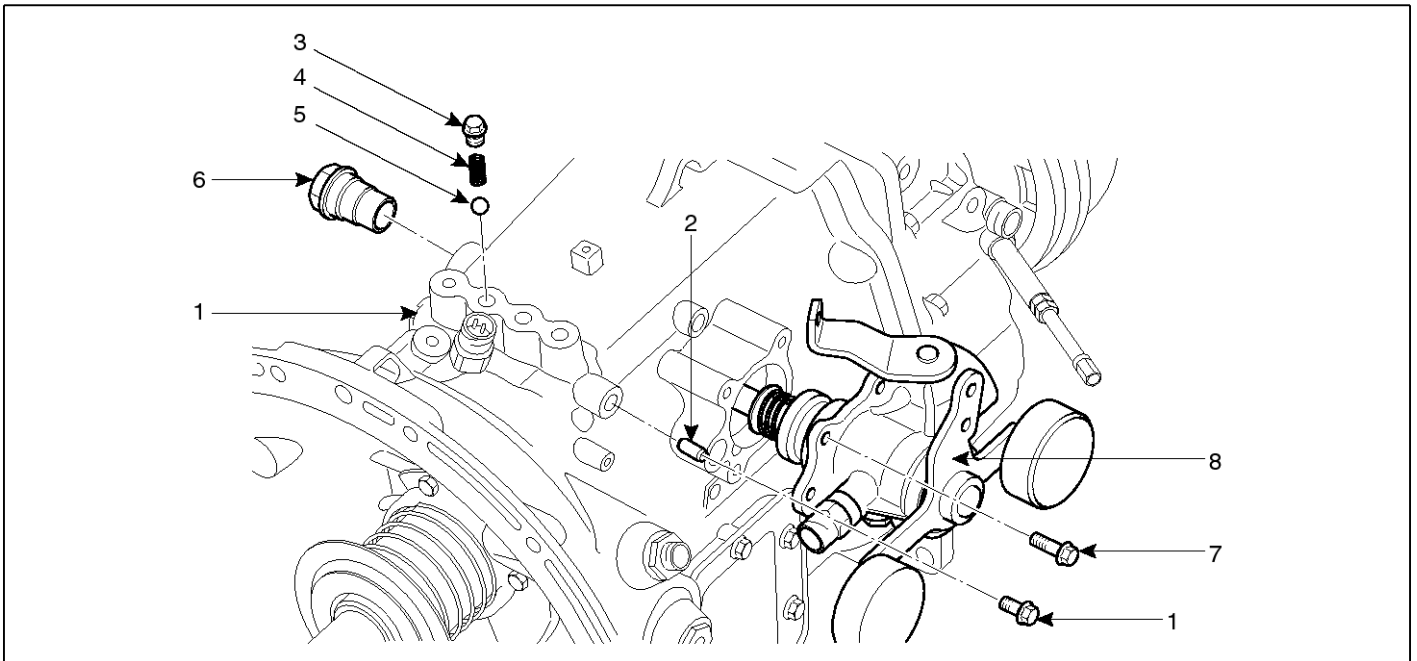

SUDMT9057D

REMOVAL PROCEDURE

1. Plug screw
2. Interlock pin
3. Bolt
4. Poppet spring
5. Ball
6. Support bolt assembly
7. Bolt
8. Upper gear shift

ASSEMBLY PROCEDURE

The assembly procedure is in the reverse order of disassembly.

SERVICE PROCEDURE

1. Removal of interlock pin

- 1) There is a hole ($\varnothing 3$) for removing the interlock pin in the 1st and reverse shift rail.

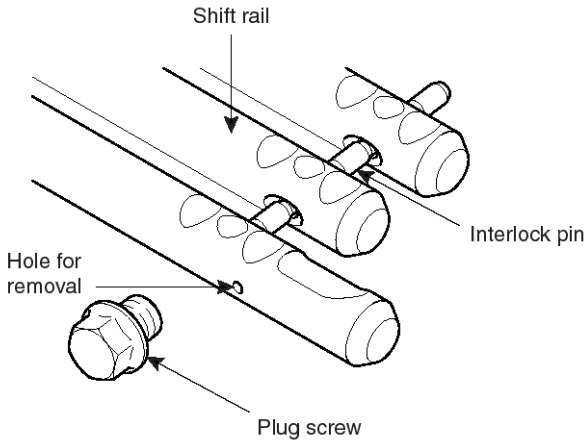

SUDMTA9010L

- 2) If the 1st and reverse shift rail is shifted into the reverse gear, the hole for removing the interlock pin meets the hole of interlock pin on other shift rail and the hole on plug screw.
- 3) Push the interlock pin out and remove it by using a wire or the like through the hole for mounting the plug screw.

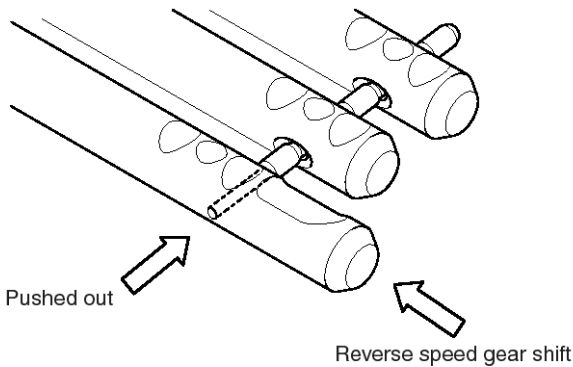

SUDMTA9011L

2. When installing it, apply sealant to the mounting surface of case or the thread part of bolt and tighten it to the specified torque.

3. Install the reverse speed light switch (A).

Tightening torque : 3.5 ~ 4.1 kgf.m (34.3~40.2 Nm, 25.3~29.7 lb.ft)

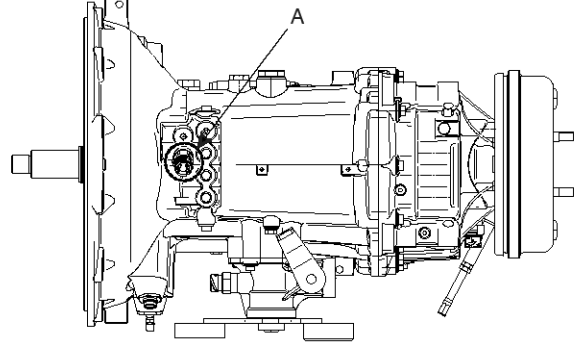

SUDMT9060D

4. Install three poppet balls, three poppet springs, and three bolts.

Tightening torque : 2.6 ~ 3 kgf.m (25.5~29.4 Nm, 18.8~21.7 lb.ft)

A : 1st gear/ reverse gear

B : 2nd gear/3rd gear

C : 4th gear/5th gear

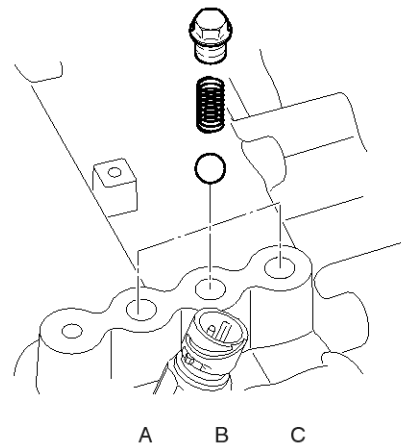

SUDMT9061D

5. When installing the gear shift upper assembly (A), incline downward and insert it. And install the gear shift upper assembly (A) with it lifted up.

Apply sealant to the assembling surface.

Tightening torque : 2.1 ~ 2.5 kgf.m (20.6~24.5 Nm, 15.2~18.1 lb.ft)

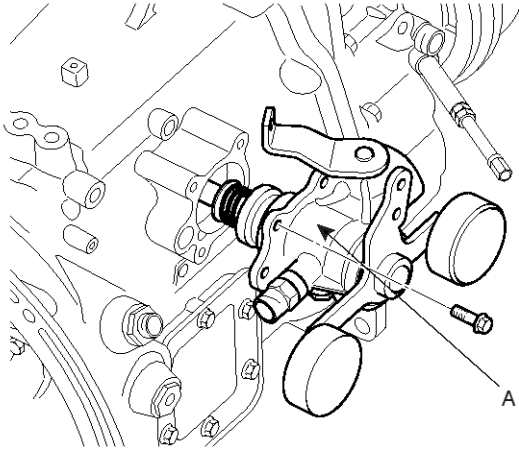

SUDMT9062D

6. Install the concentric slave cylinder (CSC) unit (A).

Tightening torque : 2.1 ~ 2.5 kgf.m (20.6~24.5 Nm, 15.2~18.1 lb.ft)

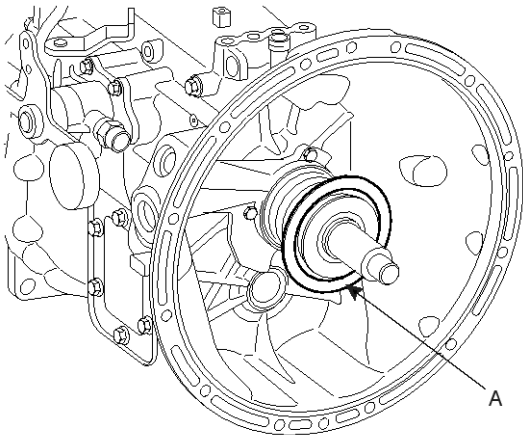

SUDMT9063D

Transmission Assembly

DISASSEMBLY

1. Remove the reverse idler shaft from the rear cover (A). Remove the O-ring (C) from the shaft. And remove 14 bolts (B).

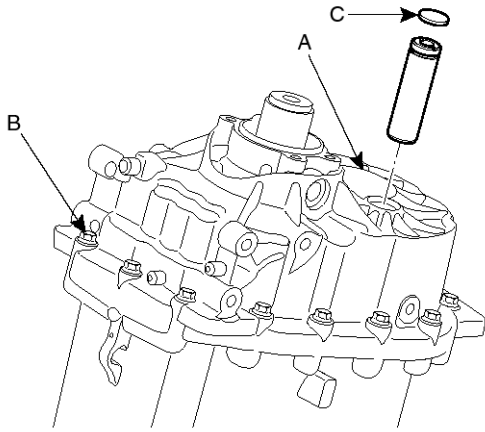

SUDMT9064D

CAUTION

Before removing the rear cover from the transmission, push the reverse idler gear (A) and the reverse idler needle bearing out in the arrow direction through the cover hole of the arrow area and then remove it.

Otherwise, the rear cover will not be disassembled with interference in the counter shaft taper bearing (B).

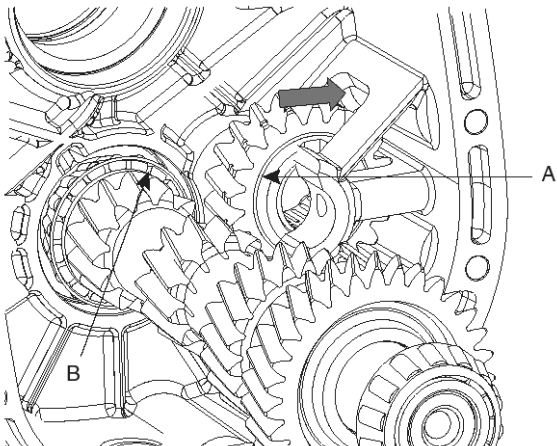

SUDMT9065D

2. Remove the bearing (A) and the idle gear (B) from the rear cover.

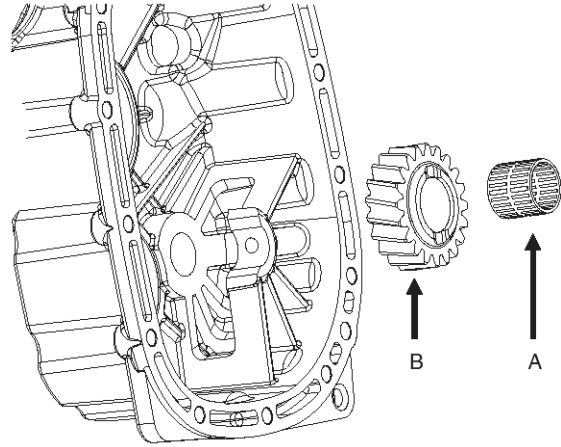

SUDMT9066D

3. Using the special tool (4405/12), remove the mainshaft rear bearing cup and the oil seal by hitting it carefully from the outside to the inside of the case.

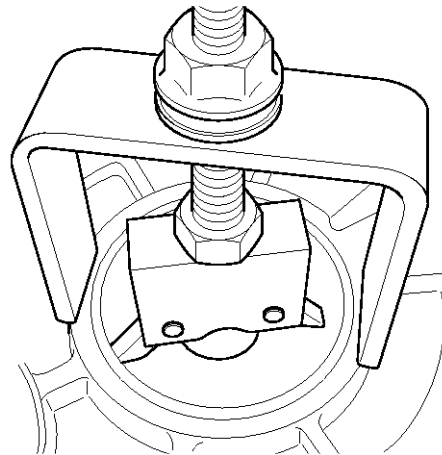

SUDMT9067D

4. Using the special tool (4405/12), remove the countershaft rear bearing cup by hitting it carefully from the outside to the inside of the case.

MT-34

5. Remove the rail subassembly (1st/R, 2nd/3rd, 4th/5th), the mainshaft subassembly, and the countershaft subassembly by tying them up with a wire as a whole from the front case.

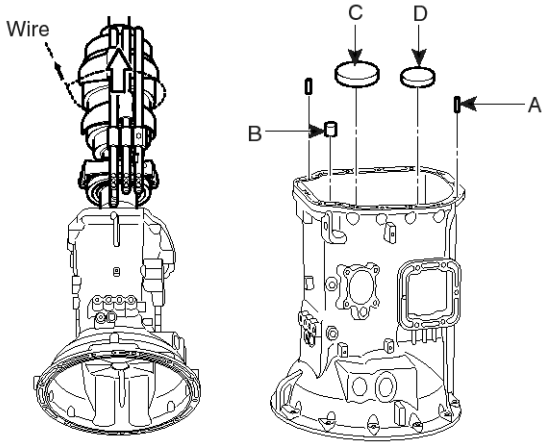

SUDMTA9017L

6. Remove the dowel pin (A) and the shift rail bush (B) from the front case.
7. Using the special tool (4405/12), remove the bearing cup (C,D).

INSTALLATION

1. Assemble the mainshaft subassembly and the countershaft subassembly on the assembling jig (4405/25) and then assemble each rail subassembly (1st/R, 2nd/3rd, 4th/5th).

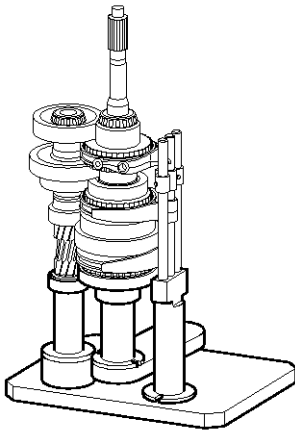

SUDMT9069D

Manual Transmission

2. Put the inner surface of the front case properly in position so that it faces up. Clean the bearing cup and the housing carefully prior to installation.
3. Using the special tool(4405/10,11), install the mainshaft and the countershaft bearing cup (C,D) by pressing them with a special tool until they settle properly against its housing.

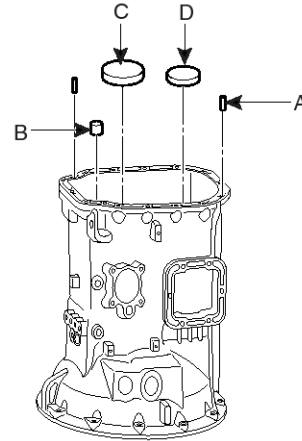

SUDMT9070D

4. Install the dowel pin (A) and shift rail bush (B) to the front case.

⚠ CAUTION

When installing the bush, assemble the opening part and the groove for bleeding air each other to have the direction of 180°.

5. Install the front cover. Be careful to install that there is no interference between the rail subassembly and the assembling hole.

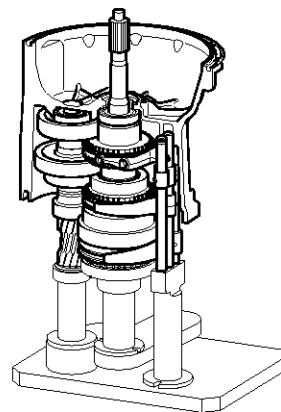

SUDMT9071D

6. Assemble the jig (4405/26) to the front case.

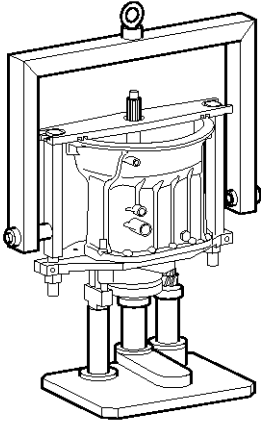

SUDMT9072D

7. Put the crane to the hole of the upper of the jig (4405/26) and rotate the front and the power train subassembly as shown in the below illustration and then move to the place where the lower surface of front case can be secured.

8. Assemble the short distance measuring jig (4405/27) of the taper roller bearing as shown in the below illustration.

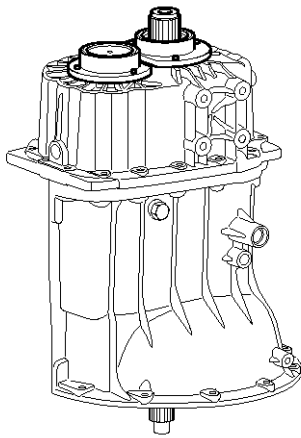

SUDMT9073D

9. The below illustration is the master dimension of the short distance measuring jig (4405/27) and indicates the example calculating shim thickness when the short distance of the jig and the rear case became the dimension marked in the hatching.

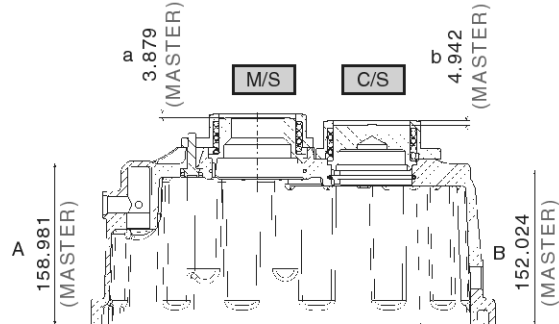

Description		Mark	Dimension	Remarks(Formula)	
Jig master	M/S	A	158.981		
		a	3.879		
	C/S	B	152.024		
		b	4.942		
Measured value	JIG	M/S	x	1.79	
		C/S	y	2.81	
	Rear case	M/S	x'	162.75	
		C/S	y'	155.75	
Clearance after adjusting shim		M/S	Gm	0	Median between -0.05 and +0.05
		C/S	Gc	0	Median between -0.05 and +0.05
Results	Short distance	M/S	X	161.07	= A + (a - x)
		C/S	Y	154.156	= B + (b - y)
	Clearance	M/S	Gm'	1.68	= x' - X
		C/S	Gc'	1.594	= y' - Y
	Shim thickness	M/S	Sm	1.68	= Gm' - Gm
		C/S	Sc	1.594	= Gc' - Gc

SUDMTA9012L

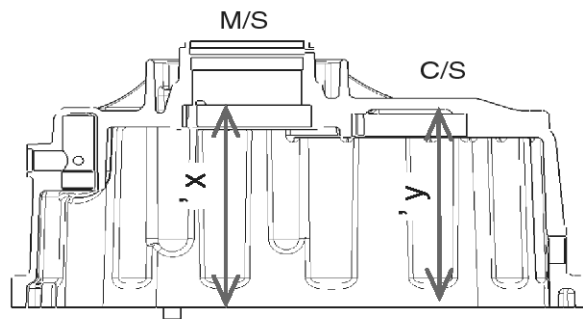

SUDMT9075D

10. Put the inner surface of the rear case properly in position so that it faces up. Clean the bearing cup and the housing carefully prior to installation.

MT-36

Manual Transmission

11. Install with the proper shims and install the mainshaft, the countershaft, the rear bearing, and shims by pressing them with the special tool(4405/11) until they settle properly against its housing.

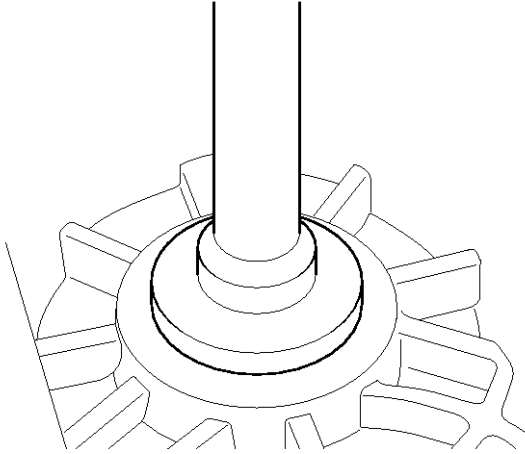

SUDMT9076D

12. Install the bearing and the idle gear to the rear cover.

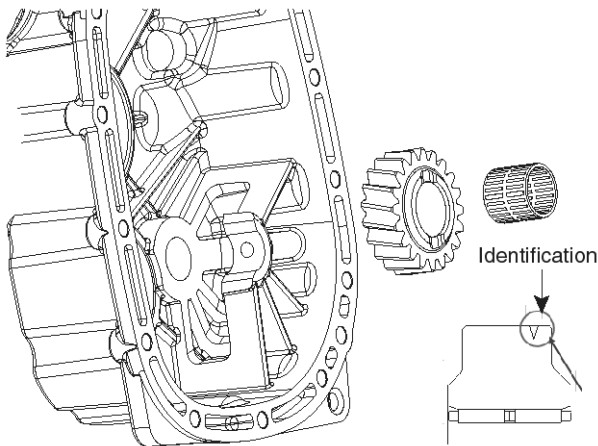

SUDMTA9500L

⚠ CAUTION

Pay attention to the assembling direction of the idler gear. (Assemble the identification groove to face to the right side.)

⚠ CAUTION

Before assembling the rear cover, push out the reverse idler gear (3) and the reverse idler needle bearing in the arrow direction and then assemble it.

Otherwise, the rear cover will not be assembled with interference in the counter shaft taper bearing (4).

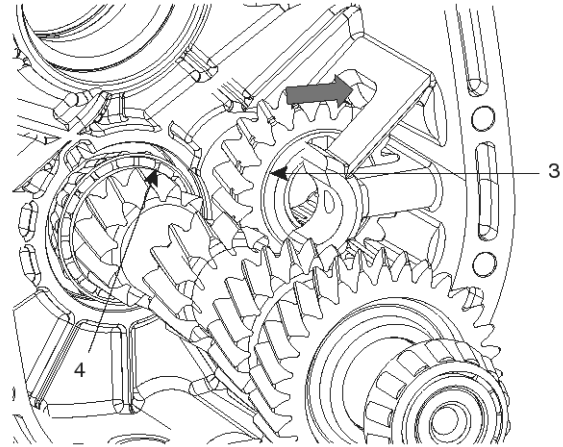

SUDMT9078D

13. Install the O-ring (3) to the groove of shaft. (Before assembling, immerse it in the transmission oil and then assemble it.)

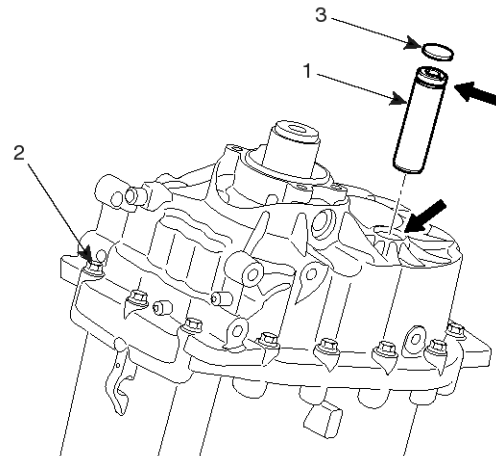

SUDMT9079D

14. Align the idler gear and bearing of the rear cover inside (arrow direction) to face to the middle of shaft and install the reverse idler shaft (1). Install the bolt (2).

⚠ CAUTION

- Apply sealant to the direction area uniformly prior to assembling the shaft.
- The oil seal removed should be replaced with a new one.

Pinion Drive

COMPONENTS

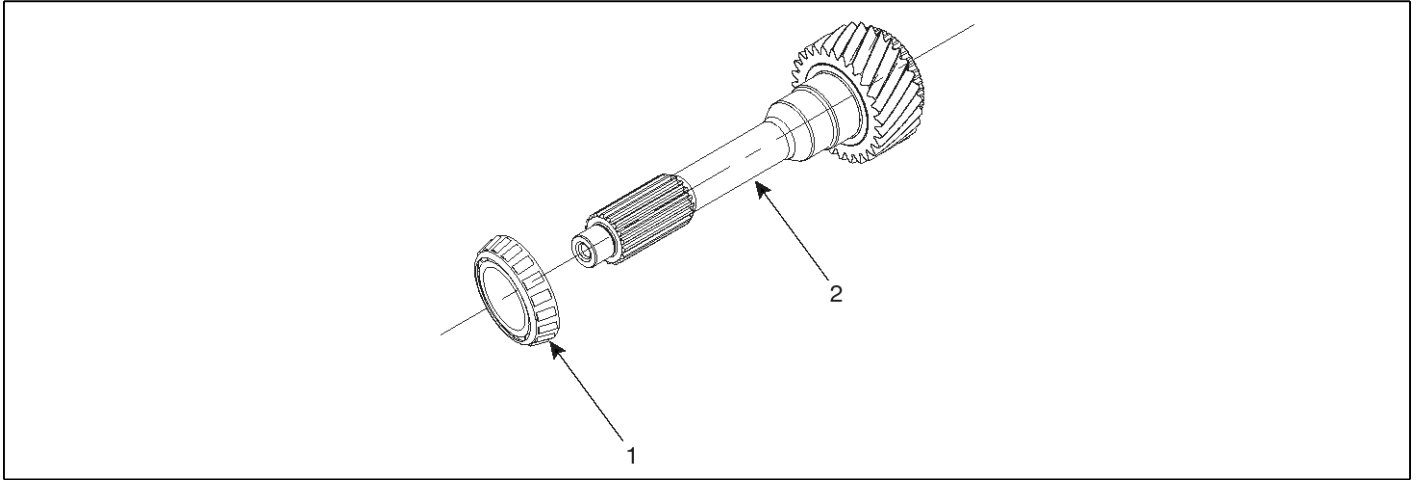

SUDMT9080D

1. Taper roller bearing

2. Pinion drive

DISASSEMBLY

1. Remove the taper roller bearing (1) from the pinion drive (2). Using the special tool (4405/05), apply pressure to the pinion drive.

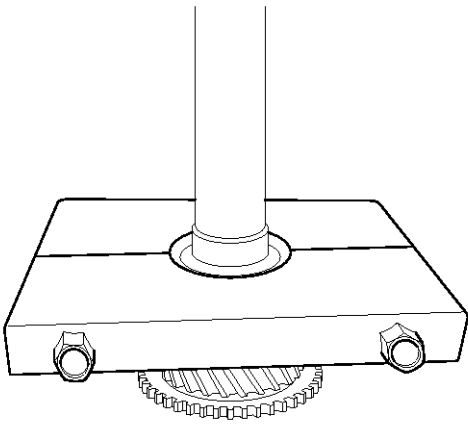

SUDMT9081D

ASSEMBLY

1. Using the tube shaped tool (4405/04), install the bearing to the pinion drive completely by applying pressure to the taper roller bearing (1).

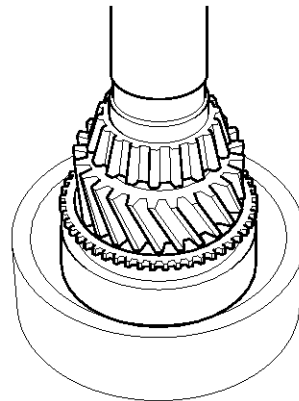

SUDMT9082D

Main Shaft

COMPONENTS

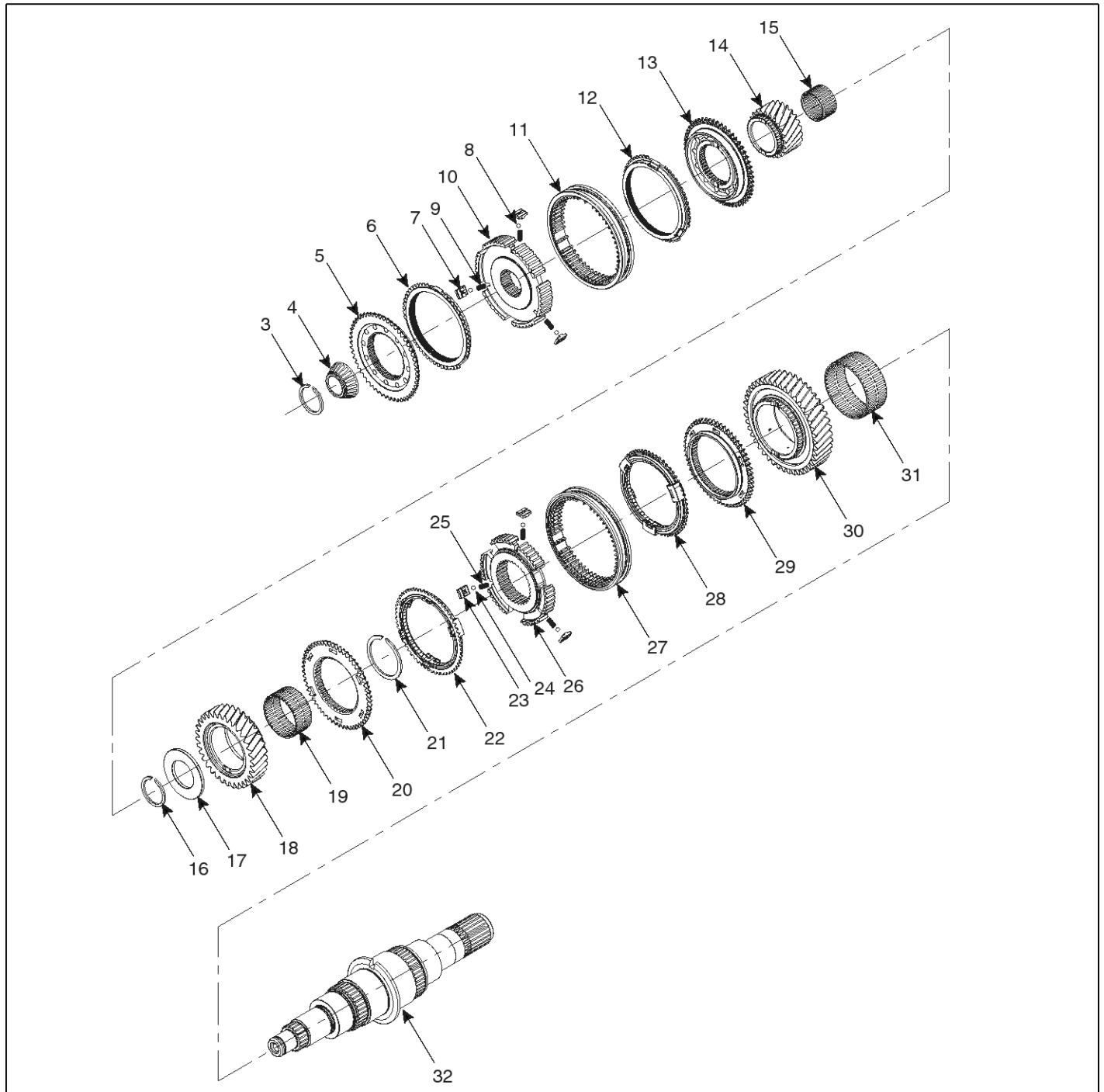

3	Snap ring	27	2nd/3rd speed sleeve
4	Pilot bearing	28	2nd speed synchronized assembly
5	4th speed gear clutch	29	2nd speed gear clutch
6	4th speed synchronizer ring	30	Mainshaft 2nd speed gear
7	Strut	31	2nd speed needle bearing
8	Ball	32	Mainshaft
9	Synchronized spring	33	1st speed needle bearing
10	4th/5th speed hub	34	Mainshaft 1st speed gear
11	4th/5th speed gear sleeve	35	1st speed gear clutch
12	5th speed synchronizer ring	36	1st speed synchronizer assembly
13	5th speed gear clutch	37	Strut
14	Mainshaft 5th speed gear	38	Ball
15	5th speed needle bearing	39	Spring
16	Snap ring	40	Hub
17	Thrust washer	41	1st /R speed sleeve
18	Mainshaft 3rd speed gear	42	Snap ring
19	3rd speed needle bearing	43	Reverse needle bearing
20	3rd speed gear clutch	44	5th speed synchronizer ring
21	Snap ring	45	5th speed speed gear clutch
22	3rd speed synchronized assembly	46	Mainshaft reverse speed gear
23	Strut	47	Thrust washer
24	Ball	48	Taper roller bearing
25	Synchronizer spring	49	Thrust impulse washer
26	2nd/3rd speed hub	50	Impulse spacer

DISASSEMBLY

1. Remove the impulse spacer (50) and the thrust impulse washer (49) from the end part of the mainshaft (32).
2. Secure the main shaft (32) in a vice to the vertical position with the end part of the front faced upward.
3. Remove the snap ring (3) from the front end surface of the shaft.
4. Using the special tool (puller 4405/22, or 4405/08), remove the pilot bearing (4).
5. Remove the 4th speed gear clutch (5).
6. Remove the 4th speed synchronizer ring (6).
7. Remove 4th/5th speed sleeve (11), strut (7), ball (8), spring (9), and hub (10) in sequence.

WARNING

Prevent the components from bouncing with a cloth since the strut and the ball are compressed with the spring.

8. Remove the 5th speed synchronizer ring (12).
9. Remove the 5th speed gear clutch (13).
10. Remove the mainshaft 5th speed gear (14).
11. Remove the 5th speed needle bearing.
12. Remove the snap ring (16).
13. Remove the thrust washer (17).
14. Remove the mainshaft 3rd speed gear (18).
15. Remove 3rd speed needle bearing (19).
16. Remove 3rd speed gear clutch (20).
17. Remove the snap ring (21).
18. Remove the 3rd speed synchronizer assembly (22).
19. Remove the 2nd/3rd speed sleeve (27), strut (23), ball (24), spring (24), and hub (26) in sequence.

WARNING

Prevent the components from bouncing with a cloth since the strut and the ball are compressed with the spring.

20. Remove the 2nd speed synchronizer assembly (28).
21. Remove the 2nd speed gear clutch (29).
22. Remove the mainshaft 2nd speed gear (30).

23. Remove the 2nd speed needle bearing (31).

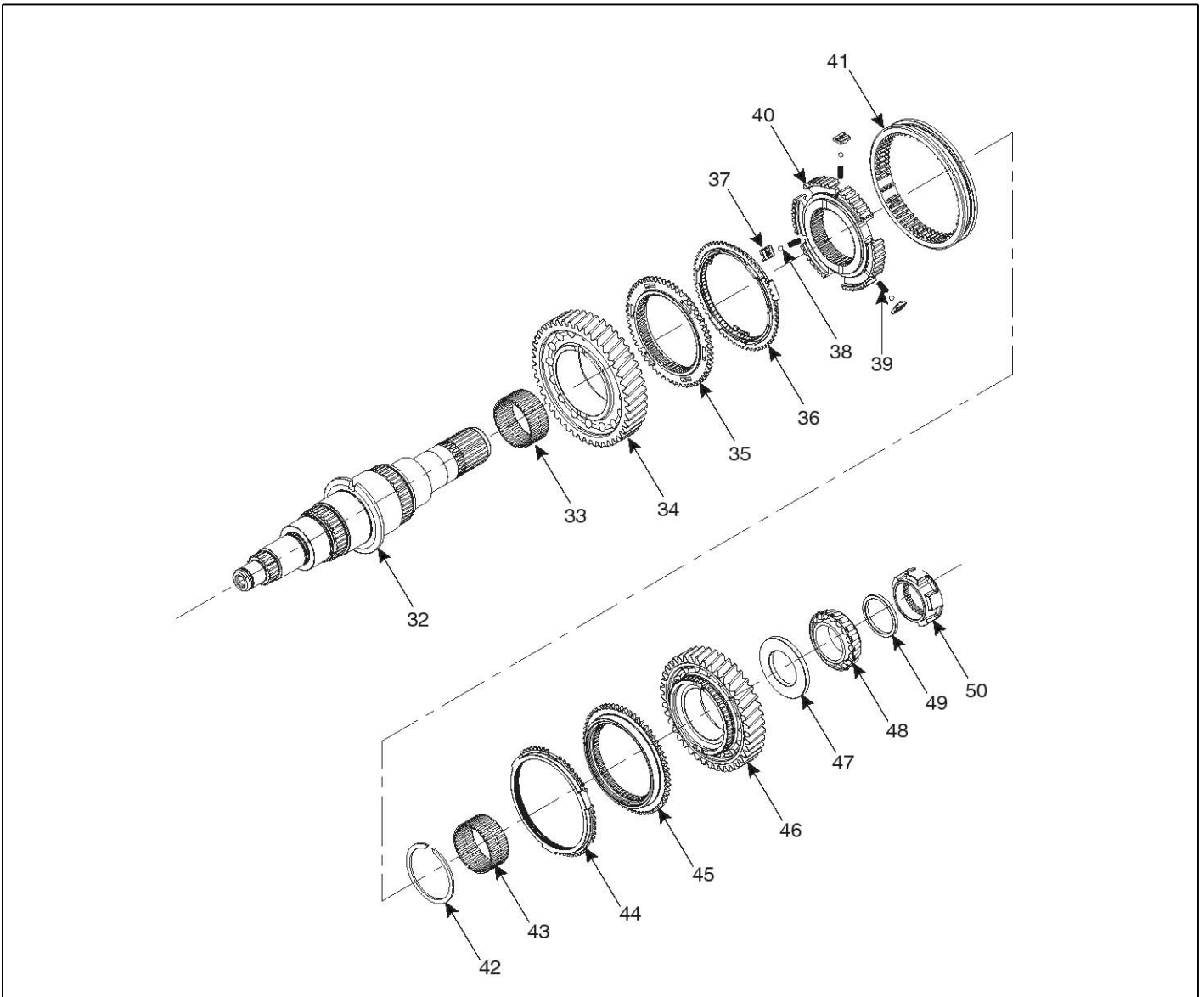

SUDMT9084D

24. Rotate the mainshaft (32). At this time, secure it to the vertical position to face the rear end part of the mainshaft (32) upward.
25. Using the special tool (puller, 4405/19), remove the taper roller bearing (48).
26. Remove the thrust washer (47).
27. Remove the mainshaft reverse speed gear (46).
28. Remove the 5th speed gear clutch (45).
29. Remove the 5th speed synchronizer ring (44).
30. Remove the reverse speed needle bearing (43).
31. Remove the snap ring (42).
32. Remove the 1st/R speed sleeve (41), strut (37), ball (38), spring (39), and hub (40) in sequence.

⚠ WARNING

Prevent the components from bouncing with a cloth since the strut and the ball are compressed with the spring.

33. Remove the 1st speed synchronizer assembly (36).
34. Remove the 1st speed gear clutch (35).
35. Remove the mainshaft 1st speed gear (34).
36. Remove the 1st speed needle bearing (33).

REASSEMBLY

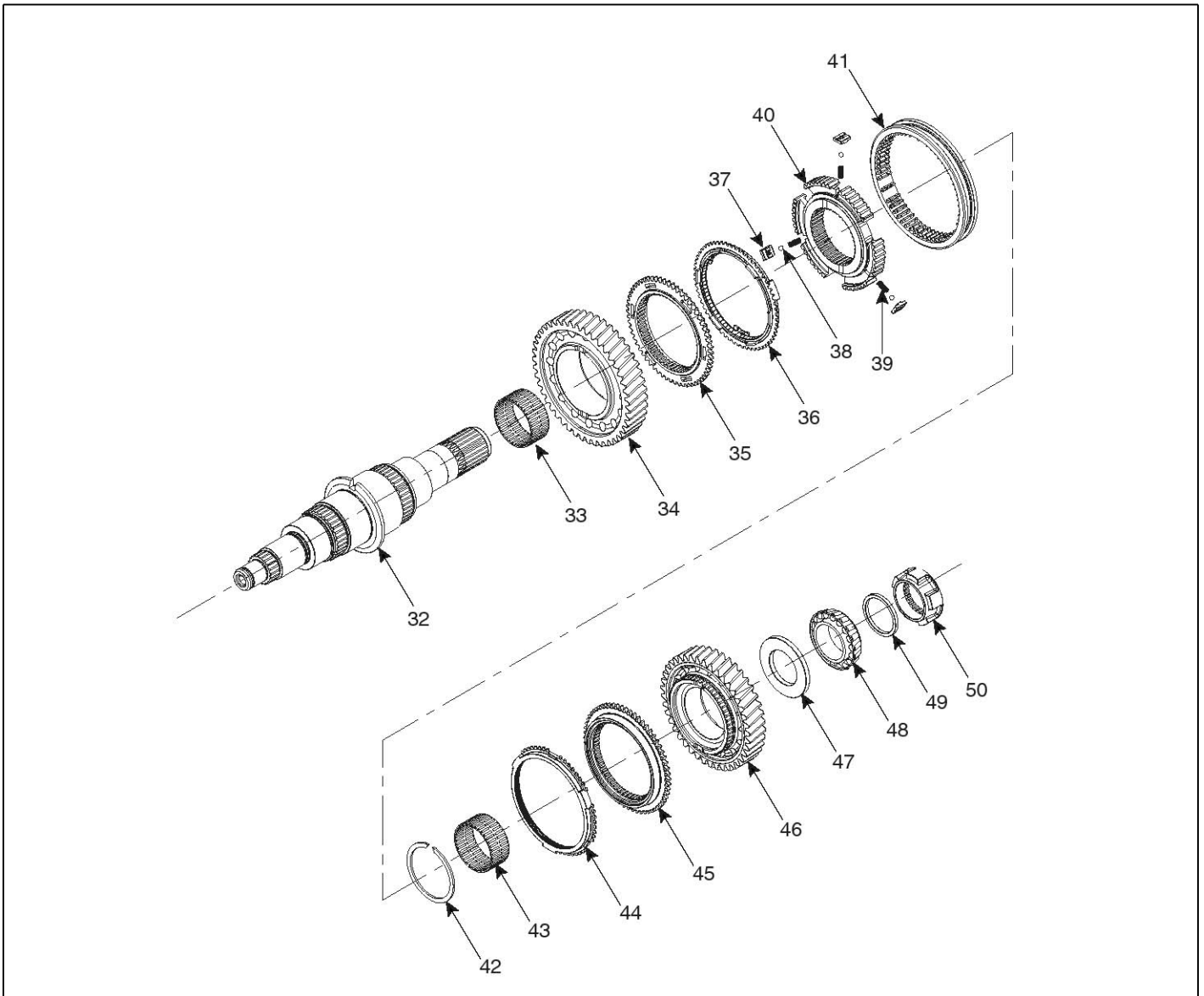

1. Face the rear end part of the mainshaft (32) upward and secure it in a vice to the vertical position.
2. Apply transmission oil to the 1st speed needle bearing (33) and install the mainshaft (32).
3. Install the mainshaft 1st speed gear (34).
4. Install the 1st speed gear clutch (35).
5. Apply transmission oil to the friction surface of the 1st speed synchronizer assembly (36) and install it.
6. Heat 1st/R speed hub (40) to 130°C~150°C for maximum 15 minutes and press it on the mainshaft (32) with a press.

⊗WARNING

When handling the hub heated, always wear protective gloves.

📄NOTICE

The 1st speed end play should be 0.14~0.37 mm.

7. Install the 1st/R speed sleeve (41), spring (39), strut (37), and ball (38) in sequence.

⚠CAUTION

Pay attention to the assembling direction of the 1st/R speed sleeve. Assemble the identification groove to face to the reverse speed side as shown in the below illustration.

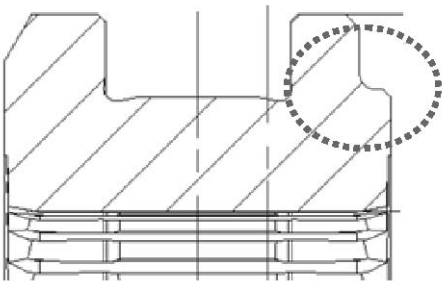

SUDMT9087D

8. Install the snap ring (42). At this time, the snap ring end play should be 0~0.07 mm.
9. Apply transmission oil to the reverse speed needle bearing (43) and install it.
10. Apply transmission oil to the friction surface of the reverse speed synchronizer ring (44) and install it.
11. Install the reverse speed gear clutch (45).
12. Install the mainshaft reverse speed gear (46).
13. Install the thrust washer (47).
14. Using the tube shaped tool (4405/17), install the bearing to the shaft completely by applying pressure to the taper roller bearing (48). At this time, locate the tube shaped tool inside bearing. Do not support the tube shaped tool in the bearing cage.

📄NOTICE

The reverse speed end play should be 0.22~0.44 mm.

15. Install the thrust impulse washer (49) and the impulse spacer (50).

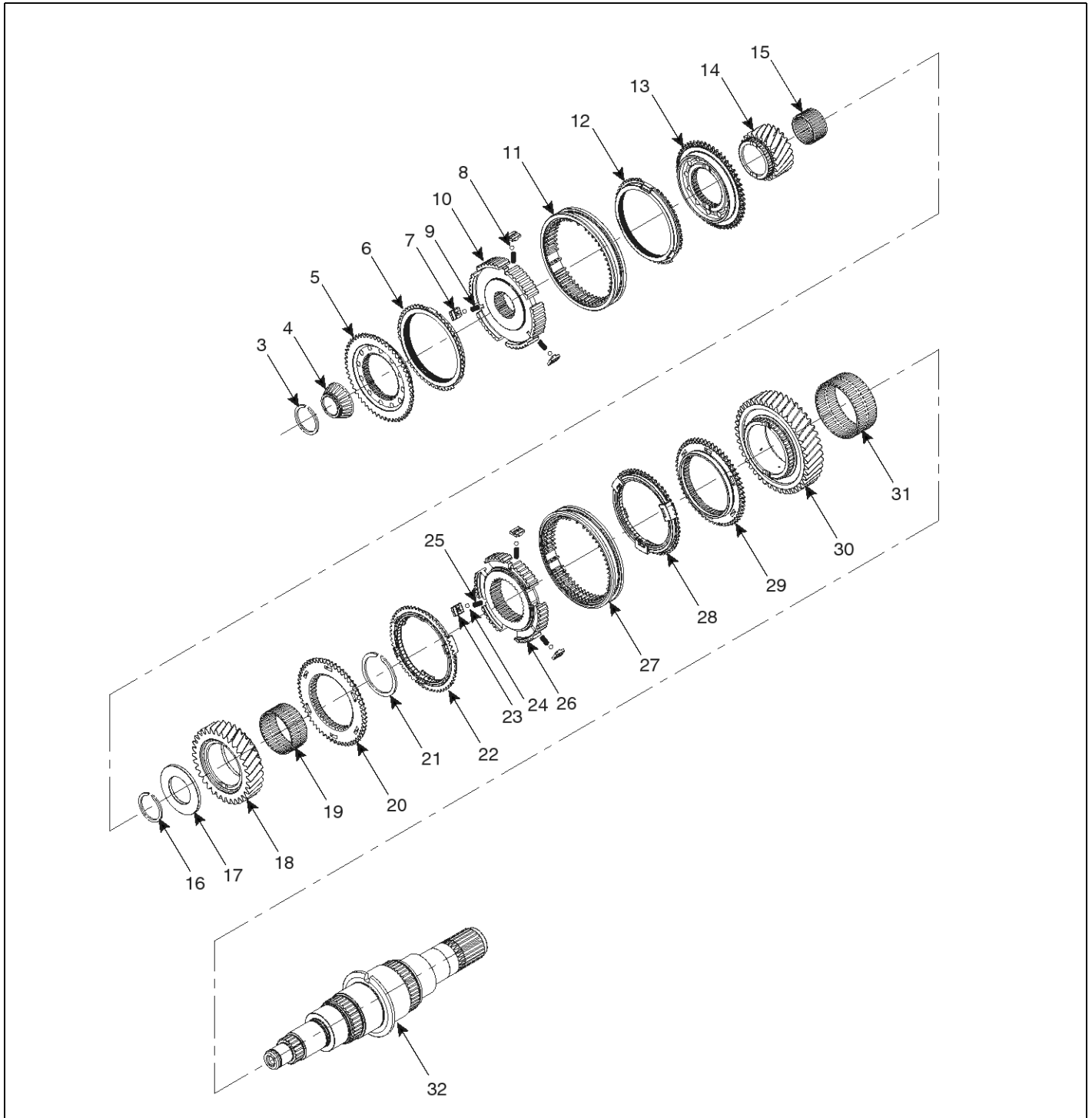

16. Secure the mainshaft (32) in a vice to the vertical position with the end part of the front faced upward.
17. Apply transmission oil to the 2nd speed needle bearing (31) and install it.
18. Install the mainshaft 2nd speed gear (30).
19. Install the 2nd speed gear clutch (29).
20. Apply transmission oil to the 2nd speed synchronizer assembly (28) and install it.
21. Heat 2nd/3rd speed hub (26) to 130°C~150°C for maximum 15 minutes and press it on the mainshaft (32) with a press.

⊗WARNING

When handling the hub heated, always wear protective gloves.

⚠CAUTION

Pay attention to the assembling direction of the 2nd/3rd speed hub. Assemble the higher speed to face to the 2nd speed side as shown in the below illustration.

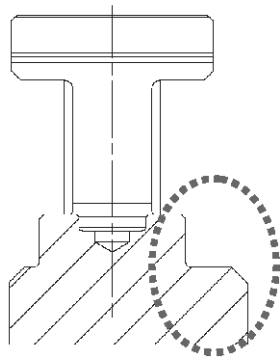

< 2nd/3rd Speed Hub >

SUDMTA9013L

22. Install the 2nd/3rd speed sleeve (27), spring (25), strut (23), and ball (24) in sequence.

⚠CAUTION

Pay attention to the assembling direction of the 2nd/3rd speed sleeve. Assemble the identification groove to face to the 3rd speed side as shown in the below illustration.

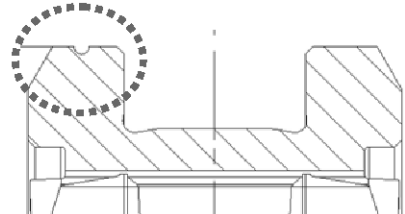

< 2nd/3rd Speed Sleeve >

SUDMTA9014L

23. Apply transmission oil to the 3rd speed synchronizer assembly (22) and install it.
24. Install the snap ring (21). At this time, the snap ring end play should be 0~0.07 mm.

📌NOTICE

The 2nd speed end play should be 0.14~0.37 mm.

25. Install the 3rd speed gear clutch (20).
26. Apply transmission oil to the 3rd needle bearing (19) and install it.
27. Install the mainshaft 3rd speed gear (18) and install it. And install the thrust washer (17).
28. Install the snap ring (16). At this time, the snap ring end play should be 0~0.07 mm.

📌NOTICE

The 3rd speed end play should be 0.11~0.33 mm.

29. Apply transmission oil to the 5th speed needle bearing and install it.
30. Install the mainshaft 5th speed gear (14) and install it. And install the 5th speed gear clutch (13).
31. Apply transmission oil to the 5th speed synchronizer ring (12) and install it.

32. Heat the 4th/5th speed hub (40) to 130°C~150°C for maximum 15 minutes and press it on the mainshaft (32) with a press.

⚠WARNING

When handling the hub heated, always wear protective gloves.

⚠CAUTION

Pay attention to the assembling direction of the 4th/5th speed hub. Assemble the higher speed face to the 5th speed side as shown in the below illustration.

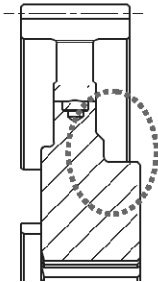

< 4th /5th Speed Hub >

SUDMTA9015L

33. Install the 4th/5th speed sleeve (11), spring (9), strut (7), and ball (8) in sequence.
34. Apply transmission oil to the 4th speed synchronizer ring (6) and install it. And install the 4th speed gear clutch (5).
35. Using the tube shaped tool (4405/17), install the pilot bearing (4) to the shaft completely by applying pressure to the taper roller bearing (48).
36. Install the snap ring (3). At this time, the snap ring end play should be 0~0.07 mm.

📌NOTICE

The 5th speed end play should be 0.27~0.43 mm.

37. Install the thrust impulse washer (49) and the impulse spacer (50).

CounterShaft

COMPONENTS

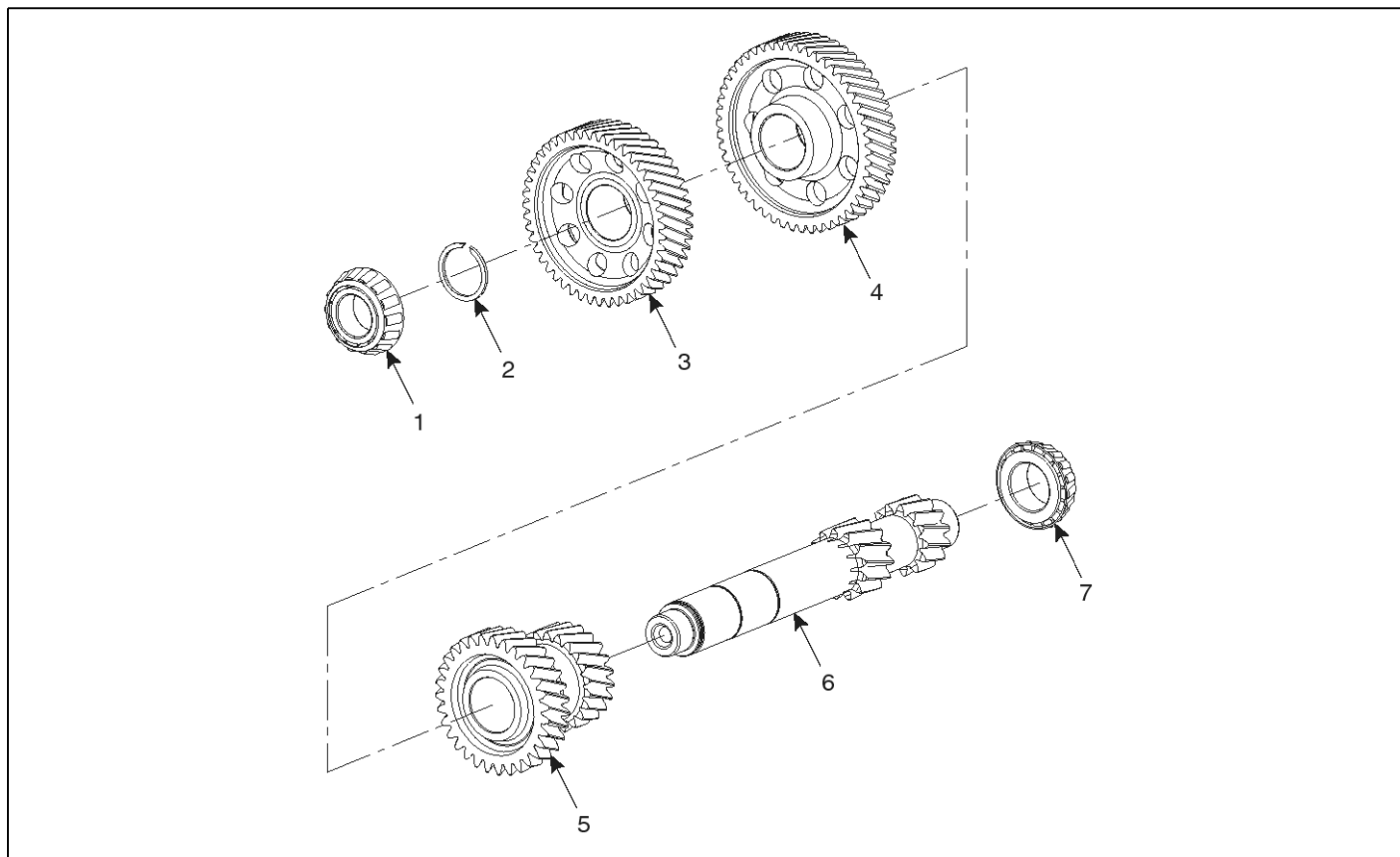

SUDMT9090D

1. Taper roller bearing
2. Snap ring
3. Countershaft constant gear
4. Countershaft 5th speed gear

5. Countershaft 2nd/3rd speed gear
6. Countershaft
7. Taper roller bearing

DISASSEMBLY

1. Face the front end part of the countershaft (6) upward and secure it in a vice to the vertical position. Using the special tool (puller, 4405/7), remove the taper roller bearing (1).

WARNING

Place the countershaft to the soft support stand and prevent it from rolling.

2. Remove the snap ring (2).
3. Remove the countershaft constant gear (3) by applying pressure to the countershaft (6).
4. Remove the countershaft 5th speed gear (4) by applying pressure to the countershaft (6).
5. Remove the countershaft 2nd/3rd speed gear (5) by applying pressure to the countershaft (6).
6. Face the rear end part of the countershaft (6) upward and secure it in a vice to the vertical position. Using the special tool (puller, 4405/7), remove the taper roller bearing (7).
7. Use the hydraulic jack suitable for removing the helical gear at a time since very high accuracy is required. The force necessary to remove each helical gear is 255kgf(2,500 N).
8. While removing, there can cause damage to each taper roller bearing inner ring. Therefore, use a new taper roller bearing to perform an exact inspection.

ASSEMBLY

1. Clean the helical gear (3,4,5) bore and countershaft (6).
2. Heat the helical gear to 160°C for maximum an hour.

WARNING

When the helical gear heated, always wear protective gloves.

3. Face the front end part of the countershaft (6) upward and rest the lower part of the reverse speed in a vice. And secure it to the vertical position.
4. Using the tube shaped tool, install the countershaft 2nd/3rd speed gear (5) by applying pressure downward to the boss part of the 3rd speed gear.
5. Using the tube shaped tool, install the countershaft 5th speed gear (4) by applying pressure downward to the boss part of the 5th speed gear.
6. Using the tube shaped tool, install the countershaft constant gear (3) by applying pressure downward to the boss part of the constant gear.
7. Install the snap ring (2).
8. Using the tube shaped tool, install the taper roller bearing (1) by applying pressure downward.
9. Face the rear end part of the countershaft (6) upward and rest the lower part of the constant gear in a vice. And secure it to the vertical position. Using the tube shaped tool (4405/08), face the small surface of the taper roller bearing (7) cone upward and apply pressure until the bearing is seated to the shaft.

Shift Rail And Shift Fork

COMPONENTS

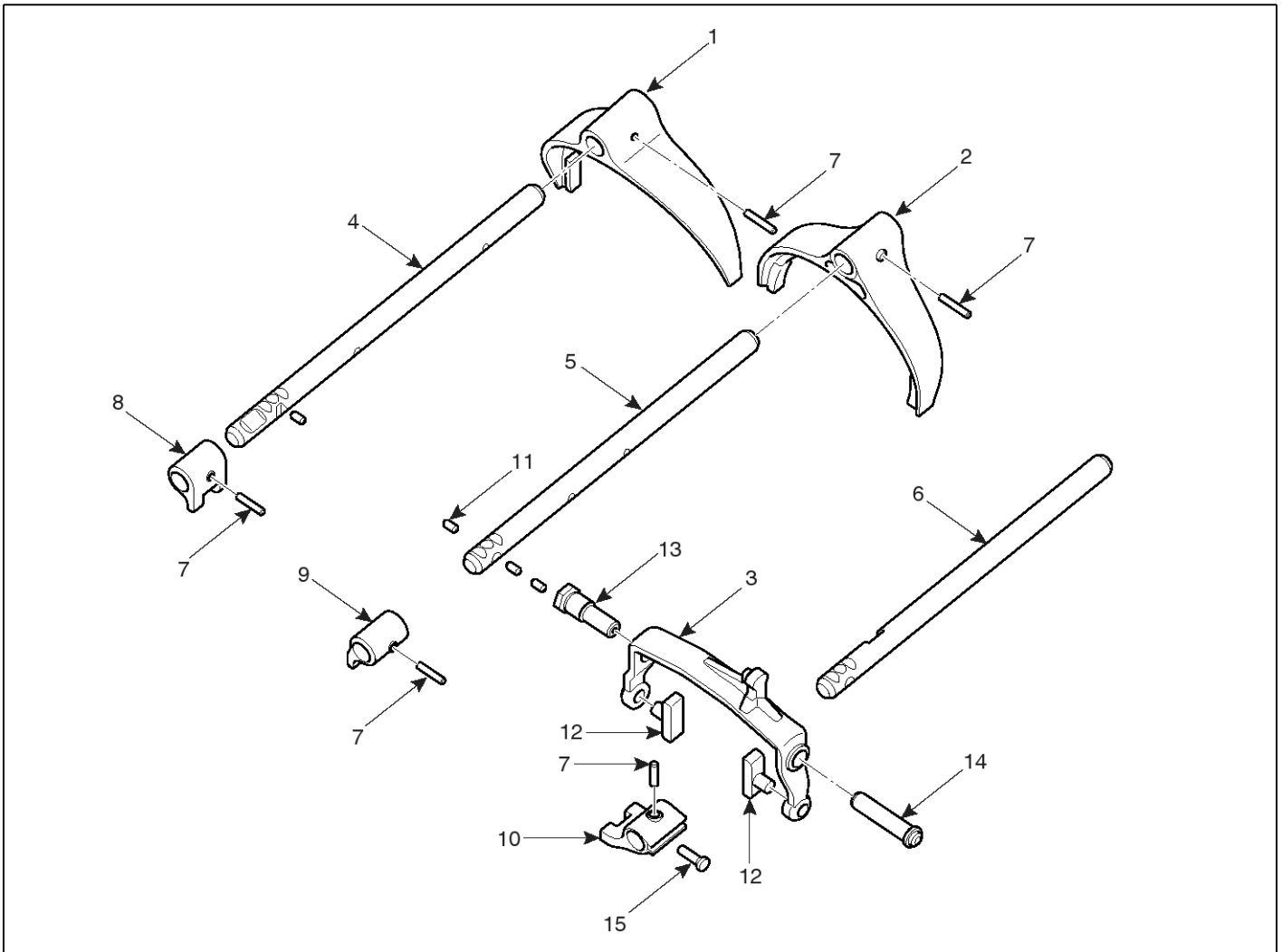

SUDMT9091D

- 1. 1st/reverse speed shift fork
- 2. 2nd/3rd speed shift fork
- 3. 4th/5th shift fork
- 4. 1st/reverse speed shift rail
- 5. 2nd/3rd speed shift rail

- 6. 4th/5th speed shift rail
- 7. Spring pin
- 8. 1st/reverse speed shift jaw
- 9. 2nd/3rd speed shift jaw
- 10. 4th/5th speed shift jaw

- 11. Interlock pin
- 12. Pad
- 13. 4th/5th speed fork mounting bolt
- 14. 4th/5th speed fork mounting pin
- 15. 4th/5th speed jaw guide bolt

DISASSEMBLY

1. The rail subassembly of the 1st/R, 2nd/3rd, 4th/5th speed is separated from the transmission main section, the fork and jaw of each speed except for 4th/5th speed fork are separated by removing the spring pin.

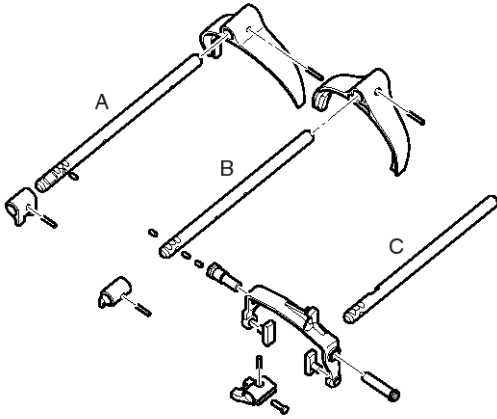

SUDMT9092D

- A : 1st and R speed rail subassembly
- B : 2nd and 3rd speed rail subassembly
- C : 4th and 5th speed rail subassembly

2. Remove the spring pin (C) of the fork (A) and jaw (B) of each speed except for 4th/5th speed fork.

NOTICE

Use the pin punch of diameter 5 mm.

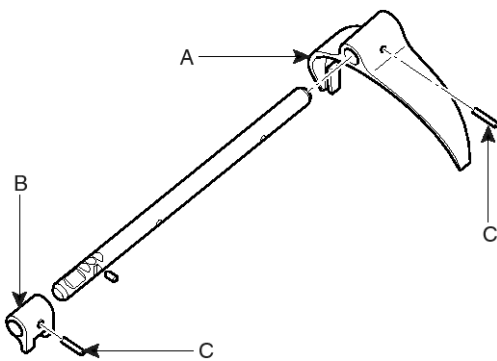

SUDMT9093D

3. Remove the jaw of each speed.
4. Remove the fork of each speed.
5. Remove the pad (A) at both ends of 4th/5th speed fork.

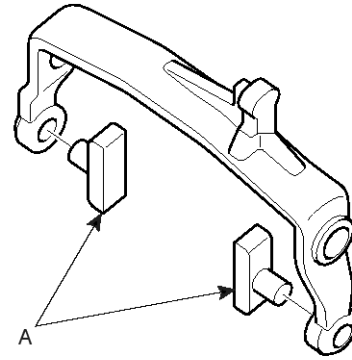

SUDMT9094D

ASSEMBLY

1. Locate the jaw and fork of 1st/R, 2nd/3rd/ 4th/5th speed to the corresponding rail, check for the mounting position related to the groove in the front of rail.
2. Align the spring pin hole (B) at the jaw with the hole (A) of rail and install a new spring pin.
3. Align the spring pin hole (C) at the fork with the hole of rail and install a new spring pin.

NOTICE

Use the pin punch of diameter 5 mm.

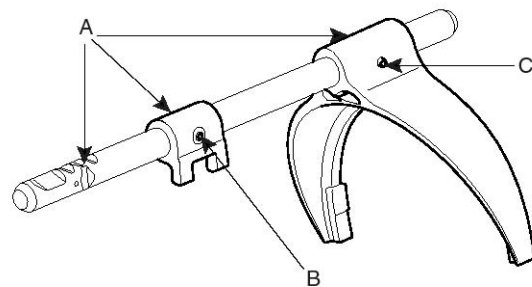

SUDMT9095D

4. Install the pad (A) at both ends of 4th/5th speed fork.

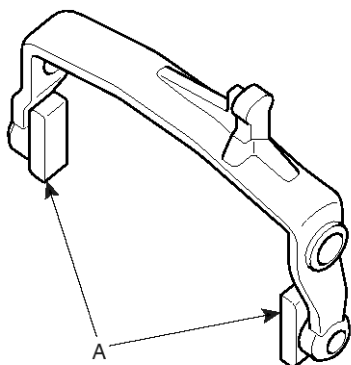

SUDMT9096D

5. The components not mentioned above are assembled in the transmission main section.

Manual Transmission Control System

Gear Shifter Lever

COMPONENTS

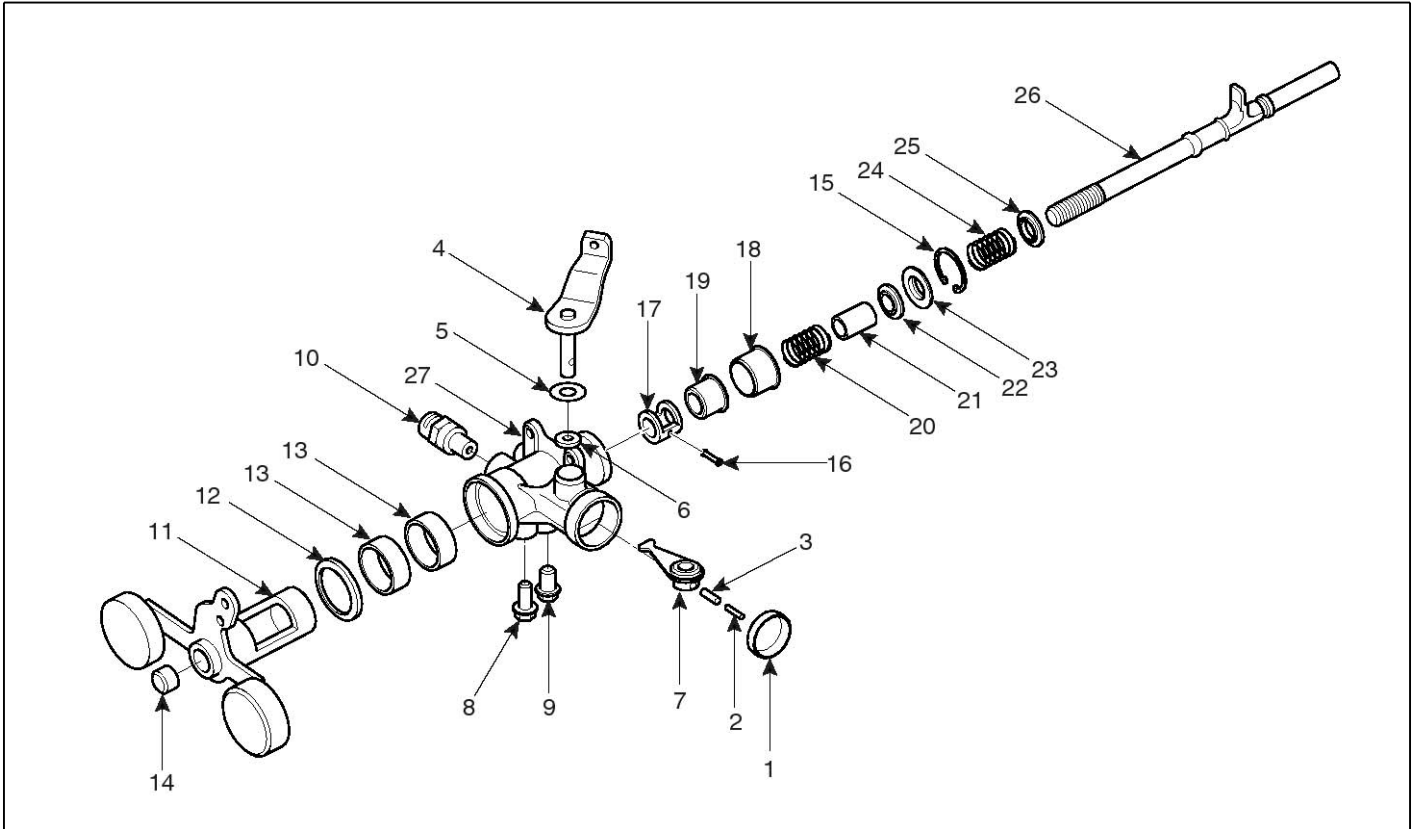

SUDMT9097D

⚠ CAUTION

- Install the plug (1) with a new one when replacing it.
- Do not remove the bush (13) except for replacing it.
- Assemble the select lever (B) and shift lever by rotating not to cause damage to the lip of the oil seal.
- When installing the kinds of bolt, apply sealant and tighten them to the specified torque.

DISASSEMBLY SEQUENCE

1. Plug
2. Spring pin
3. Spring pin
4. Select lever (B)
5. Plain washer
6. Oil seal
7. Select lever (A)
8. Set bolt
9. Poppet ball assembly
10. Interlock switch
11. Shift lever
12. Oil seal
13. Bush
14. Plug
15. Retainer ring
16. Spring pin
17. Select lug
18. Retainer (A)
19. Retainer (B)
20. Return spring (1/R)
21. Spacer
22. Retainer
23. Retainer
24. Return spring (4/5)
25. Retainer
26. Torsion shaft

ASSEMBLY SEQUENCE

Assembly is in the reverse order of disassembly.

SERVICE PROCEDURE

1. Assembly of Torsion Shaft

- 1) When assembling the inner spline of shift lever and the outer spline of torsion shaft, assemble them to the angle of 20° between the center line of shift lever hole and the center line of torsion shaft lever.

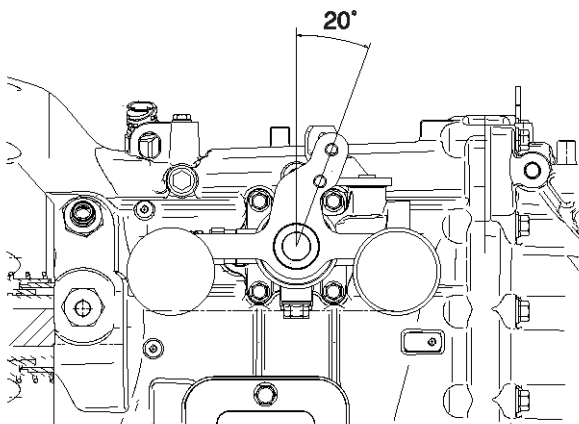

SUDMT9098D

2. Assembly of Oil Seal of Shift Lever

Apply grease to the lip of oil seal and press-fit it evenly as shown in the illustration.

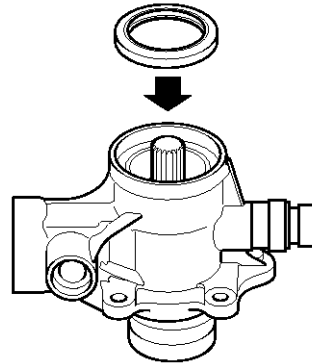

SUDMT9099D

3. Assembly of Oil Seal of Select Lever

Apply grease to the lip of oil seal and press-fit it evenly as shown in the illustration.

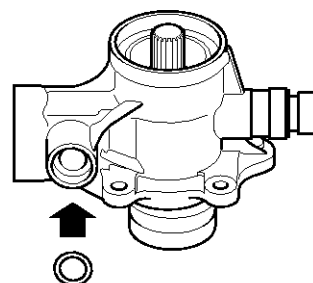

SUDMT9100D

4. Assembly of Dust Plug of Select Lever

Apply Loctite 648 or 962 around the periphery surface of dust plug and press-fit it evenly as shown in the illustration.

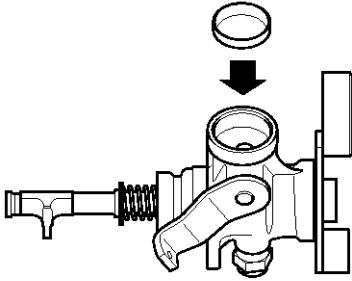

SUDMT9101D

5. Assembly of Dust Plug of Shift Lever

Apply Loctite 648 or 962 around the periphery surface of dust plug and press-fit it evenly as shown in the illustration.

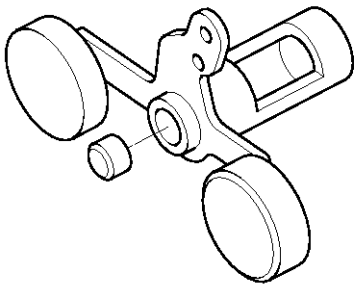

SUDMT9102D

Shift Cable And Select Cable Assembly

COMPONENTS

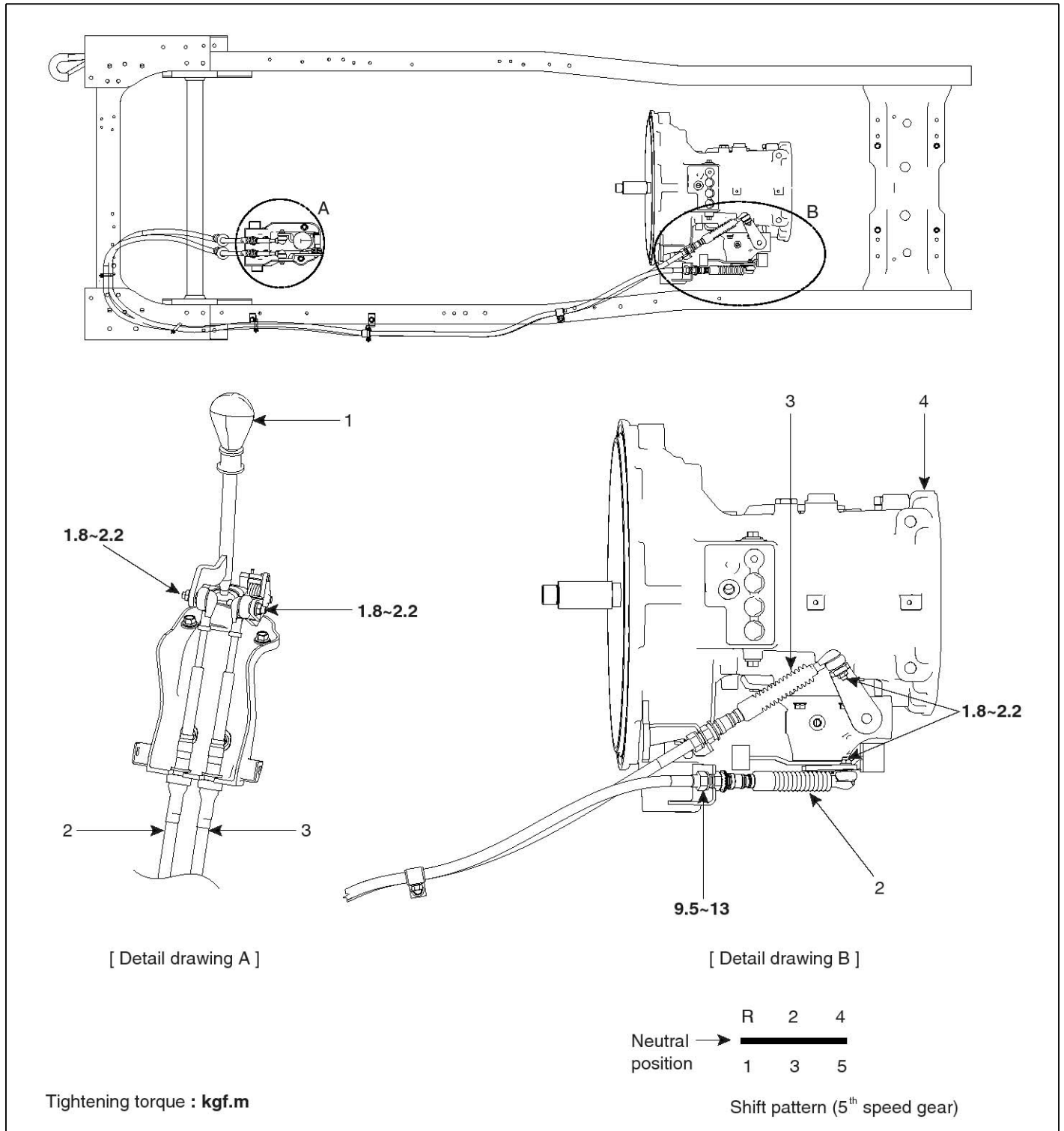

SUDMTA9016L

- 1. Transmission knob
- 2. Shift cable assembly

- 3. Select cable assembly
- 4. Transmission assembly

REMOVAL

1. Remove the center console.
2. Disconnect the clip (A) and then disconnect the shift cable (B) and select cable (C) from the shift lever.

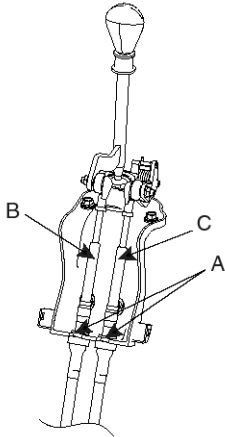

SUDMT9104D

3. Remove the shift cable (A) and select cable (B) in the transmission side.

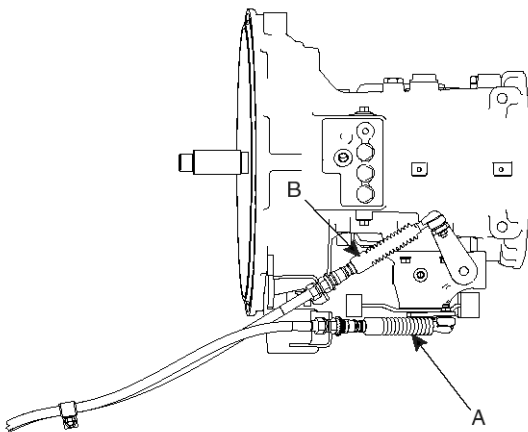

SUDMT9105D

4. Disconnect the middle strap.

INSTALLATION

1. Installation is the reverse order of removal.

⚠ CAUTION

1. Make sure the shift and select lever is in the Neutral position and install it.
2. Regarding tightening torque value, see page components.